

eXcellence 792PRO

| Instruction Book |

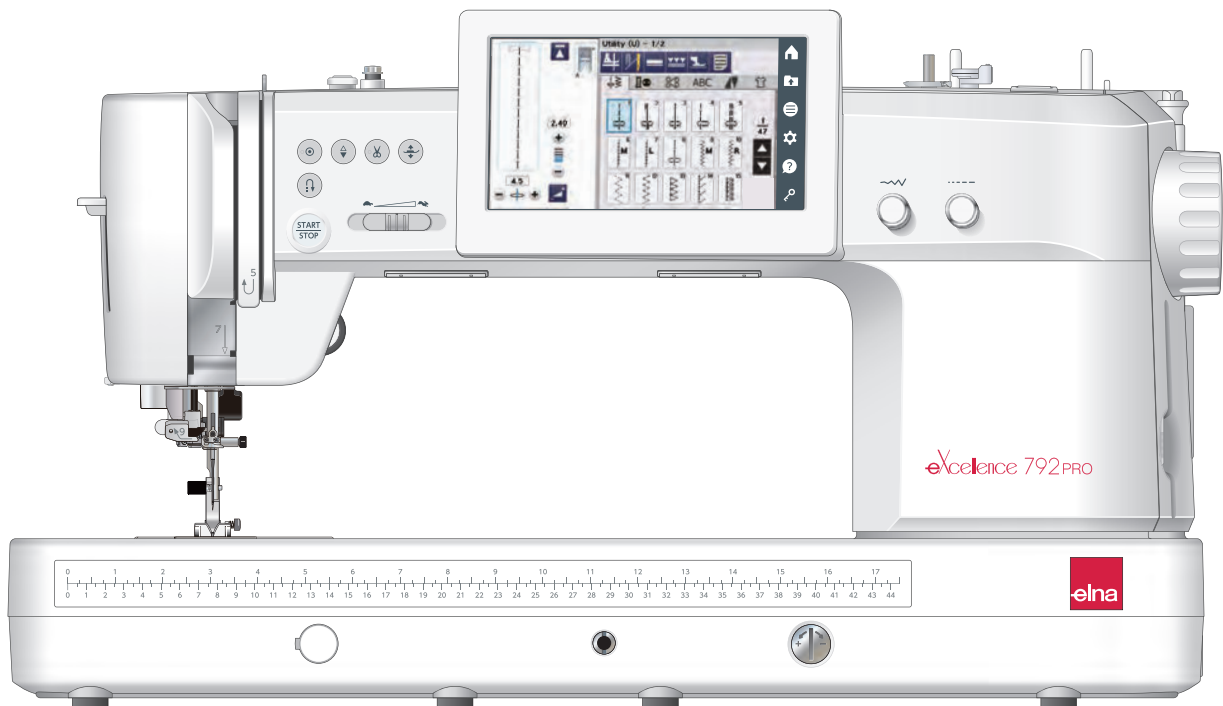

Before You Use the Machine

WARNING:

This product contains a lithium button/coin cell battery. If a new or used lithium button/coin cell battery is swallowed or enters the body, it can cause severe internal burns and can lead to death in as little as 2 hours. Always completely secure the battery compartment. If the battery compartment does not close securely, stop using the product, remove the batteries, and keep it away from children. If you think batteries might have been swallowed or placed inside any part of the body, seek immediate medical attention.

When you start the machine for the first time, be sure to remove the tape from the battery cover on the rear side of the machine.

- (1) Tape
- (2) Battery cover

Set the clock after removing the tape from the battery cover (refer to page 137).

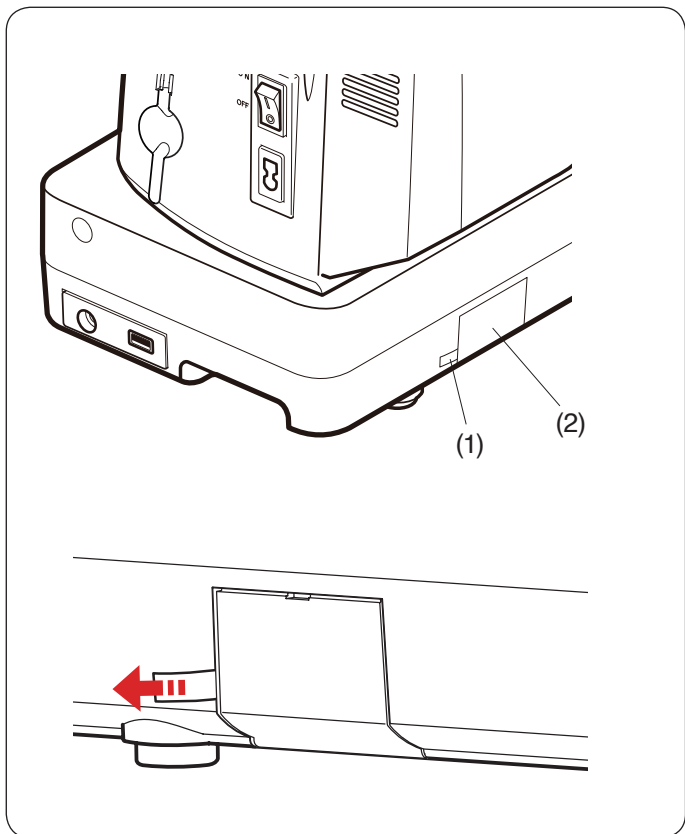

IMPORTANT SAFETY INSTRUCTIONS

When using an electrical appliance, basic safety precautions should always be followed, including the following:

This sewing machine is designed and manufactured for household use only.

Read all instructions before using this sewing machine.

DANGER— To reduce the risk of electric shock:

1. An appliance should never be left unattended when plugged in. Always unplug this sewing machine from the electric outlet immediately after using and before cleaning.

WARNING— To reduce the risk of burns, fire, electric shock, or injury to persons:

1. Do not allow to be used as a toy. Close attention is necessary when this sewing machine is used by or near children.
2. Use this appliance only for its intended use as described in this owner's manual. Use only attachments recommended by the manufacturer as contained in this owner's manual.
3. Never operate this sewing machine if it has a damaged cord or plug, if it is not working properly, if it has been dropped or damaged, or dropped into water. Return this sewing machine to the nearest authorized dealer or service center for examination, repair, electrical or mechanical adjustment.
4. Never operate the appliance with any air opening blocked. Keep ventilation openings of this sewing machine and foot controller free from accumulation of lint, dust and loose cloth.
5. Never drop or insert any object into any opening.
6. Do not use outdoors.
7. Do not operate where aerosol (spray) products are being used or where oxygen is being administered.
8. To disconnect, turn all controls to the off ("O") position, then remove plug from outlet.
9. Do not unplug by pulling on cord. To unplug, grasp the plug, not the cord.
10. Keep fingers away from all moving parts. Special care is required around the sewing machine needle and/or cutting blade.
11. Always use the proper needle plate. The wrong plate can cause the needle to break.
12. Do not use bent needles.
13. Do not pull or push fabric while stitching. It may deflect the needle causing it to break.
14. Switch this sewing machine off ("O") when making any adjustment in the needle area, such as threading the needle, changing the needle, threading the bobbin or changing the presser foot, and the like.
15. Always unplug this sewing machine from the electrical outlet when removing covers, lubricating, or when making any other adjustments mentioned in this owner's manual.

SAVE THESE INSTRUCTIONS

For Europe only:

This appliance can be used by children aged from 8 years and above and persons with reduced physical, sensory or mental capabilities or lack of experience and knowledge if they have been given supervision or instruction concerning use of the appliance in a safe way and understand the hazards involved. Children shall not play with the appliance. Cleaning and user maintenance shall not be made by children without supervision.

For outside Europe (except U.S.A.):

This appliance is not intended for use by persons (including children) with reduced physical, sensory or mental capabilities, or lack of experience and knowledge, unless they have been given supervision or instruction concerning use of the appliance by a person responsible for their safety. Children should be supervised to ensure that they do not play with the appliance.



Please note that on disposal, this product must be safely recycled in accordance with relevant National legislation relating to electrical/electronic products. If in doubt please contact your retailer for guidance. (EEA (European Economic Area) and UK)

TABLE OF CONTENTS

ESSENTIAL PARTS

Names of Parts.....	4
Standard Accessories.....	5
Foot Control and Thread Cutter Switch.....	8
Adjusting the Thread Cutter Switch Position.....	8
Extra Wide Table.....	10
How to Carry the Sewing Machine.....	10

GETTING READY TO SEW

Connecting the Power Supply.....	11
Using Start/Stop Button.....	11
Using Foot Control.....	12
Thread Cutter Switch.....	13
Controlling Sewing Speed.....	14
Speed Control Slider.....	14
Foot Control.....	14
Machine Operating Buttons.....	15
Bobbin Winding Button and Jog Dials.....	17
Thumb Wheel.....	17
Touch Panel Keys.....	18
On-screen Help.....	19
Raising and Lowering the Presser Foot.....	20
Knee Lifter.....	20
Replacing the Presser Foot.....	21
Removing and Attaching the Foot Holder.....	22
Attaching Dual Feed Foot AD or Dual Feed Plus Professional Foot HP2.....	23
Attaching the Ruler Work Foot QR.....	23
Attaching the Professional Grade Foot HP.....	23
Attaching the Darning Foot PD-H or the Darning Foot PD-H (open-toe).....	24
Replacing Needles.....	24
Fabric and Needle Chart.....	25
Using the Straight Stitch Needle Plate.....	25
Winding the Bobbin.....	26
Inserting the Bobbin.....	29
Threading the Machine.....	30
Guide Sticker for Threading.....	31
Built-in Needle Threader.....	32
Drawing Up the Bobbin Thread.....	33
Replacing the Needle Plate.....	34

ORDINARY SEWING MODE

Ordinary Stitch Patterns.....	35
Function Keys.....	37
Utility Stitches.....	39
Straight Stitches.....	39
Sewing from the Edge of Thick Fabric.....	39
Changing Sewing Direction.....	39
Turning a Square Corner.....	39
Securing Seams.....	40
Cutting Threads.....	40
Needle Plate Guides.....	40
Variety of Straight Stitches.....	41
Sewing with the Dual Feed Drive.....	42
Dual Feed Plus Professional Foot HP2.....	43
Sewing with the Professional Grade Foot HP.....	44
Floating Mode.....	45
Variety of Zigzag Stitches.....	46
Variety of Overcasting Stitches.....	47

Manual Stitch Settings.....	48
Adjusting Thread Tension.....	49
Adjusting Foot Pressure Control.....	50
Number of Locking Stitches.....	50
Foot Up for Pivoting.....	50
Favorite Stitch Adjustment.....	51
Cloth Guide.....	53
Other Utility Stitches.....	54

BUTTONHOLES AND SPECIALTY STITCHES

Variety of Buttonholes.....	56
B1 Sensor (Square) Buttonhole.....	57
Double Layer Buttonhole.....	59
Manual Settings.....	60
Using the Stabilizer Plate.....	61
B2 Automatic (Square) Buttonhole.....	62
Other Buttonholes.....	64
B13 Welted Buttonhole (Bound Buttonhole).....	65
Corded Buttonhole.....	67
Specialty Stitches.....	67
B14 Button Sewing.....	67
B15 Darning.....	68
B16 Tacking.....	69
B17 Fly Stitch.....	69
B18-B22 Eyelets.....	69

DECORATIVE STITCHES

Decorative Stitches.....	70
Quilting.....	79
Using the Quilting Guide Bar.....	79
Q1-Q3 Patchwork Piecing.....	79
Angle Scales on the Needle Plate.....	79
Quilt Block Advisor.....	80
Q80-Q85 Hand-Look Quilt Stitches.....	82
Satin Stitches.....	82
Elongation Ratio.....	82
Mirage Stitches.....	83
Created Stitches.....	84
Twin Needle Sewing.....	85

PROGRAMMING A PATTERN COMBINATION

Mirror Image of Patterns.....	87
Bridge Stitches.....	87
Editing a Pattern Combination.....	88
Deleting a Pattern.....	88
Inserting a Pattern.....	88
Startover Key.....	89
Checking Pattern Combination Length.....	90
Tapering.....	91
Tapered Stitch Sample 1.....	91
Auto-lock Stitch Function.....	92
Flipping the Tapered Pattern 1.....	92
Adjustment of Tapered Stitches.....	93
Flipping the Tapered Pattern 2.....	94
Tapered Stitch Sample 2.....	95

TABLE OF CONTENTS

MONOGRAMMING

Function Keys.....	97
Manual Thread Tension.....	98
Individual Thread Tension Adjustment.....	98
Unified Thread Tension Adjustment.....	98
Spacing.....	98
Reducing the Size of Letters.....	98
Programming a Monogram.....	99
Saving a Pattern Combination.....	101
Creating a New Folder.....	101
Deleting a File or Folder.....	101
Changing a File Name or Folder Name.....	102
Opening a Pattern Combination.....	102

HAND STITCH STYLE

Hand Stitch Style.....	103
------------------------	-----

SEWING APPLICATION

Variety of Sewing Applications.....	104
Sewing.....	105
Seaming Woven.....	105
Seaming Stretch/Knit.....	105
Curve.....	105
Topstitching.....	105
Rolled Hem.....	106
Overedge Woven.....	107
Overedge Stretch/Knit.....	107
Overedge Heavy.....	107
Blind Hem.....	108
Shell Tuck.....	110
Lapped Zipper.....	110
Invisible Zipper.....	113
Pouch Zipper.....	115
Gathering.....	117
Easestitching.....	117
Basting.....	118
Buttonhole.....	118
Button.....	119
Tacking.....	120
Eyelet.....	121
Smocking.....	122
Fagoting.....	122
Quilt.....	123
Patchwork Piecing.....	123
Free Motion.....	124
Accurate Stitch Regulator Function/A.S.R. Foot Holder.....	125
Changing the Foot Attachment.....	127
Ruler Work.....	128
Variable ZZ.....	129
Applique.....	130
Straight Stitch (with Dual Feed).....	131
Decorative Quilt Stitch.....	131
Clasp Stitch.....	131
Sashiko.....	132
Hand-Look QU.....	132

INFORMATION AND CUSTOMIZING

Quick Stitch Select.....	133
Quilt Block Advisor.....	133

Manual Dual Feed Setting.....	134
Machine Information.....	135
Customizing Machine Settings.....	136
Machine Setting Mode.....	137
Sewing Setting Mode.....	139
Language Setting Mode.....	141

CARE AND MAINTENANCE

Cleaning the Hook Area.....	142
Correcting Distorted Stitch Patterns.....	143
Replacing the Coin Cell Battery for the Internal Clock.....	144
Replacing the Needle Plate for Emergency.....	145
Problems and Warning Signals.....	146
Troubleshooting.....	147
Formatting USB Flash Drives.....	149
Stitch Chart.....	151
Stitch Chart (Monogram).....	153

ESSENTIAL PARTS

Names of Parts

- (1) Face plate
- (2) Thread take-up lever
- (3) Left thread guide
- (4) Upper thread guide
- (5) Bobbin winding tension disk
- (6) Visual touch screen
- (7) Retractable thread guide
- (8) Bobbin winder spindle
- (9) Bobbin winder stopper
- (10) Bobbin thread cutter (upper)
- (11) Bobbin winding button
- (12) Stitch length adjusting dial (Jog dial)
- (13) Stitch width adjusting dial (Jog dial)
- (14) Feed balancing dial
- (15) Knee lifter socket
- (16) Needle plate release dial cap
- (17) Carrying handle (lower)
- (18) Thread cutter (on face plate)
- (19) Needle threader lever
- (20) Lower thread guide
- (21) Needle clamp screw
- (22) Needle bar thread guide
- (23) Needle
- (24) Zigzag foot A
- (25) Hook cover release button
- (26) Hook cover plate
- (27) Bobbin thread cutter
- (28) Needle plate
- (29) Feed dogs
- (30) Foot holder
- (31) Thumbscrew
- (32) Lever
- (33) Needle threader
- (34) Buttonhole lever
- (35) Thumb wheel
- (36) Start/stop button
- (37) Reverse button
- (38) Auto-lock button
- (39) Needle up/down button
- (40) Thread cutter button
- (41) Presser foot lifter button
- (42) Speed control slider
- (43) Presser foot lifter
- (44) Dual feed drive
- (45) Spool pins
- (46) Battery cover
- (47) Power switch
- (48) Machine socket
- (49) USB port
- (50) Foot control jack
- (51) Touch panel stylus holder
- (52) Handwheel
- (53) Right thread guide
- (54) Carrying handle (upper)
- (55) Attachment connector cover

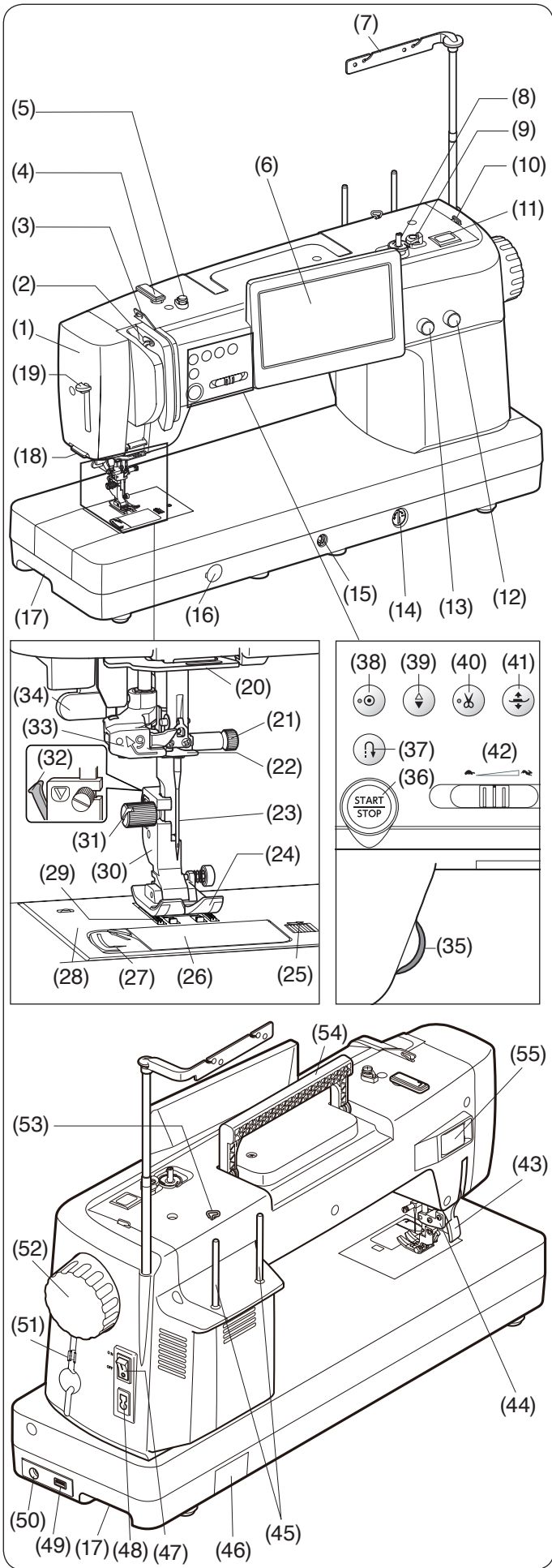

NOTE:

Sewing machine design and specifications are subject to change without prior notice.

NOTE:

To carry the sewing machine, refer to page 10.

Standard Accessories

No.	Part Name	Part No.
1	Zigzag foot A (Set on the machine)	859802006
2	Overcasting foot M	859810007
3	Satin stitch foot F	859806011
4	Blind hemming foot G	859807001
5	Zipper foot E	859805009
6	Invisible zipper foot Z	859815002
7	Automatic buttonhole foot R	862822013
8	Stabilizer plate	859832016
9	Rolled hem foot D	859804008
10	Open-toe satin stitch foot F2	859813000
11	Button sewing foot T	859811008
12	1/4" seam foot O	859814012
13	1/4" seam foot O (without guide)	202313104
14	Professional grade foot HP	865803006
15	Darning foot PD-H	859839002
16	Darning foot PD-H (open-toe)	859839013
17	Dual feed holder	859817015
18	Dual feed foot AD	859819109
19	Dual feed plus professional foot HP2	865522008
20	Free motion quilting closed-toe foot QC	859836009
21	Free motion quilting open-toe foot QO	859837000
22	Free motion quilting zigzag foot QV	859812009
23	Variable zigzag open-toe foot QZ	862895006
24	Ruler work foot QR	862896007
25	Button shank plate	832820007
26	Bobbin x 5* (1 set on the machine)	102261103
27	Needle set	859856005
28	Lint brush	802424004
29	Seam ripper (buttonhole opener)	647808009
30	Quilting guide bar	755802001
31	Screwdriver	820832005
32	Net x 2*	624806006
33	Spool holder (large) x 2*	822020503
34	Spool holder (small) x 2*	822019509
35	Spool holder (special) x 2*	862408008
36	Spool rest x 2*	770850001
37	Knee lifter	846417011
38	Touch panel stylus	860194002
39	Needle plate (set on the machine)	867642001
40	Hook cover plate	809136100
41	Straight stitch needle plate	867802001
42	Professional grade needle plate HP	867803002
43	Hook cover plate (HP)	809136A01

* This is a part number of single item (not set number).

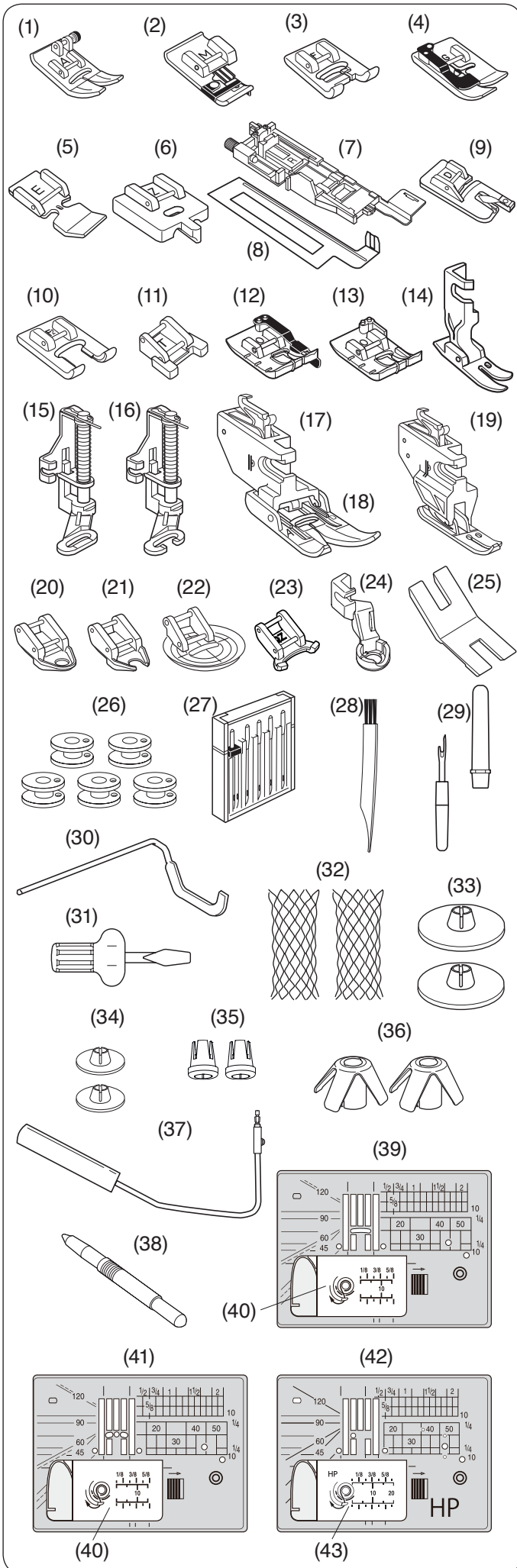

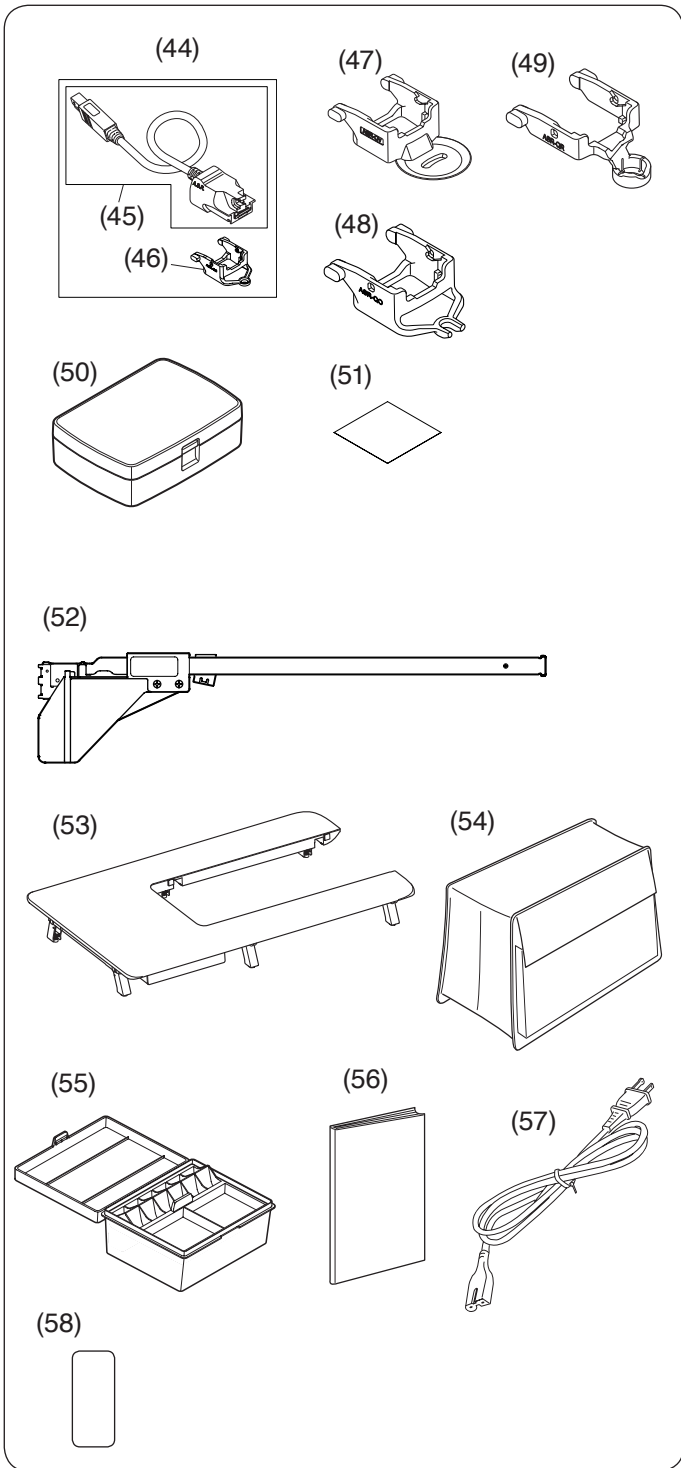

No.	Part Name	Part No.	
44	A.S.R. (Accurate Stitch Regulator) with ASR-QC	868835006	
45	A.S.R.*	868835017	
46	A.S.R. closed-toe foot ASR-QC	868837008	
47	A.S.R. clear-view foot ASR-QV	868837204	
48	A.S.R. open-toe foot ASR-QO	868837101	
49	A.S.R. ruler work foot ASR-QR	868837307	
50	A.S.R. case	869408010	
51	A.S.R. instruction card	103334A01	
52	Cloth guide	868827005	
53	Extra wide table	867806016	
54	Semi-hard fabric cover	867801103	
55	Accessory box	866801018	
56	Instruction book	867800401	
57	Power supply cable**	U.S.A. and Canada	856519004
		U.K.	830377008
		Australia	830314018
		Continental Europe	830335004
58	Threading guide sticker	101627A08	

* Remove the A.S.R. from the sewing machine when you use the semi-hard fabric cover. A.S.R. (Accurate Stitch Regulator) may be an optional item depending on your model.

** The power supply cable included may differ from the illustration.

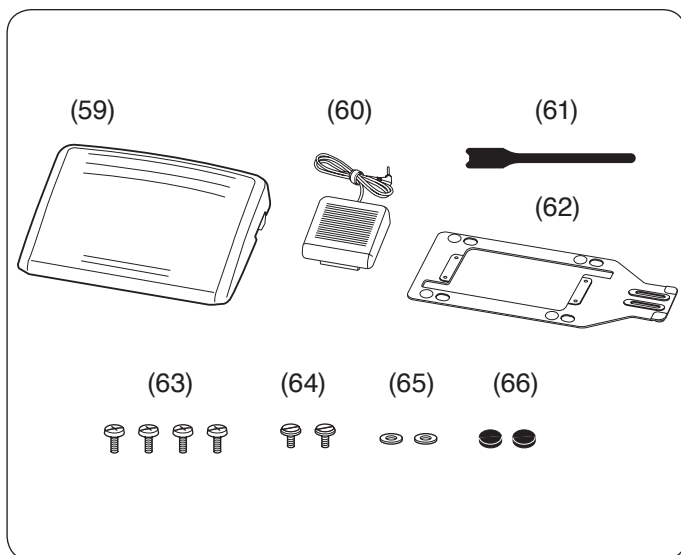

No.	Part Name	Part No.
59	Foot control	043770104
60	Thread cutter switch	867811003
61	Cable tie	767849306
62	Base plate	767849100
	*Rubber sole x 6**	525010005
63	Setscrew A x 4**	000081005
64	Setscrew B x 2**	865045002
65	Washer x 2**	000072508
66	Rubber sole x 2**	525010005

* Rubber sole x 6 are already attached on the under side of the base plate.

** This is a part number of single item (not set number).

Instructional Video

A presentation video with quick-start information for this model is available online and can be accessed using the following QR code.



<https://www.youtube.com/playlist?list=PLzURYW7eSwbEXxepTpZ8ZiBGuD7opz6BG>

Download application for PC

From this QR code or URL, you can download StitchComposer, ScreenSaverTool and QuiltBlockAdvisor for Windows.



<https://global.elna.com/excellence-792pro-pc-software/>

Optional accessories

Optional accessories for this model are available by accessing the following QR code.



<https://global.elna.com/optional-accessories/>

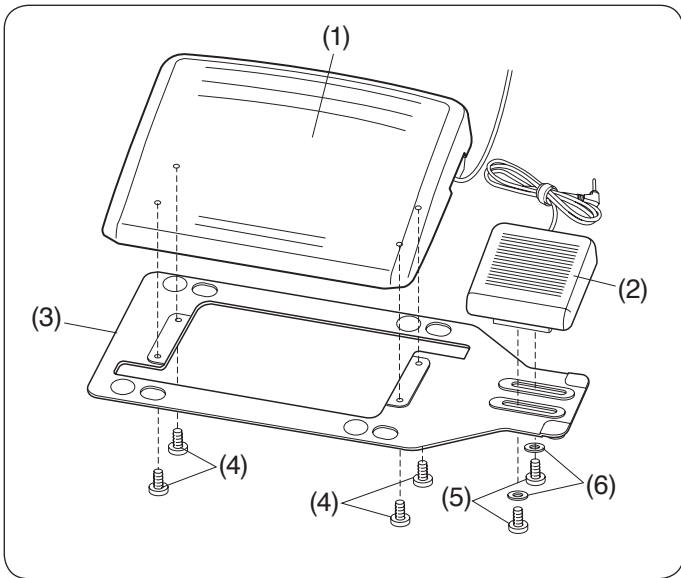

Foot Control and Thread Cutter Switch

To attach the foot control and the thread cutter switch to the base plate, tighten setscrews A, and setscrews B with washers as shown.

- (1) Foot control
- (2) Thread cutter switch
- (3) Base plate
- (4) Setscrew A
- (5) Setscrew B
- (6) Washer

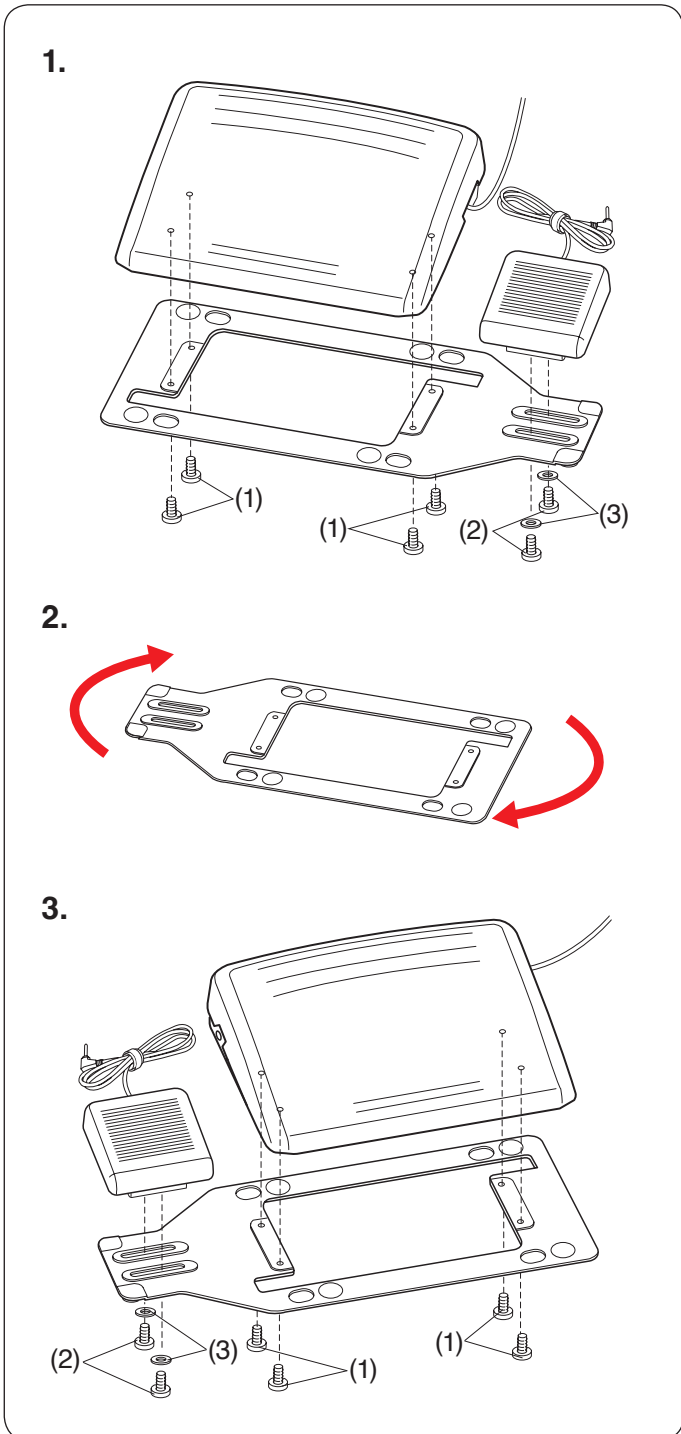

Adjusting the Thread Cutter Switch Position

Placing the thread cutter switch to the left.

The thread cutter switch position can be adjusted for your convenience.

If you wish to attach the thread cutter switch to the left side of the foot control, follow the procedure below.

NOTE:

A Phillips head screwdriver is not included with this machine.

1. Remove the setscrews A, B and washers with a Phillips head screwdriver.

- (1) Setscrew A
- (2) Setscrew B
- (3) Washer

2. Turn the base plate 180 degrees.

3. Attach the foot control and thread cutter switch with the setscrews A, B and the washers. Tighten the setscrews A and B. Be sure that the cable is not caught between the foot control and the base plate.

- (1) Setscrew A
- (2) Setscrew B
- (3) Washer

1.

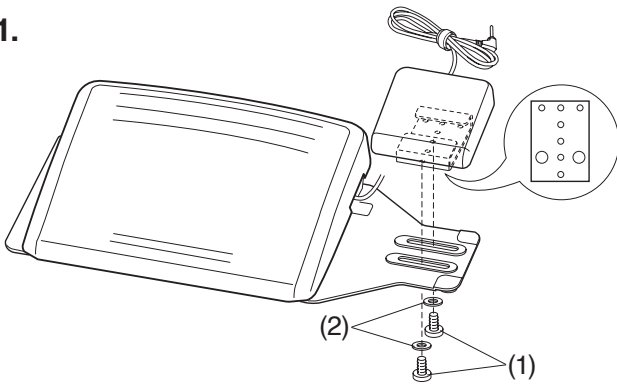

2.

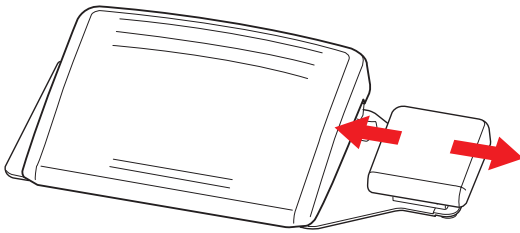

Adjusting the horizontal position of the thread cutter switch

1. Loosen the setscrews B under the switch.

- (1) Setscrew B
- (2) Washer

2. Slide the switch to the left or right, and fix it at the desired position by tightening the setscrews B with a screwdriver.

1. 2.

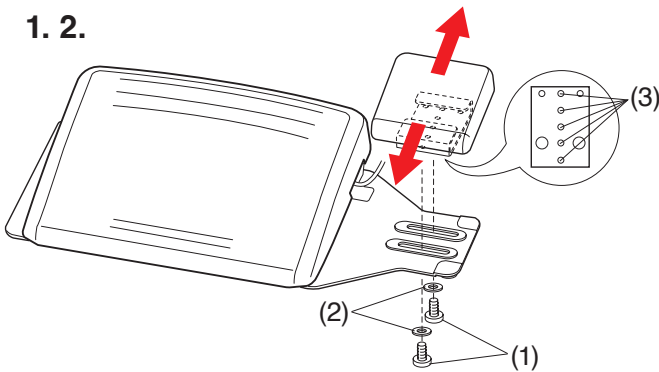

Adjusting the vertical position of the thread cutter switch

1. Remove the setscrews B and washers.

2. Move the switch forward or backward, attach the switch at the desired position and fix it with the setscrews B and washers.

- (1) Setscrew B
- (2) Washer
- (3) Desired position

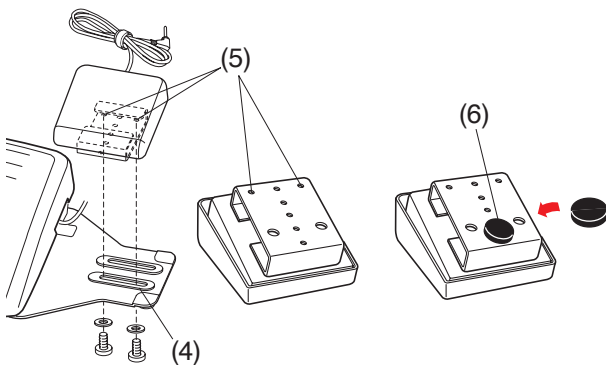

NOTE:

- To fix the thread cutter switch at its lowest position, fix the setscrews B into the hole (4), and then holes (5).
- Tighten the setscrews B securely.
- Peel off the backing paper from the rubber sole (6) and attach it to the bottom of the thread cutter switch as shown.

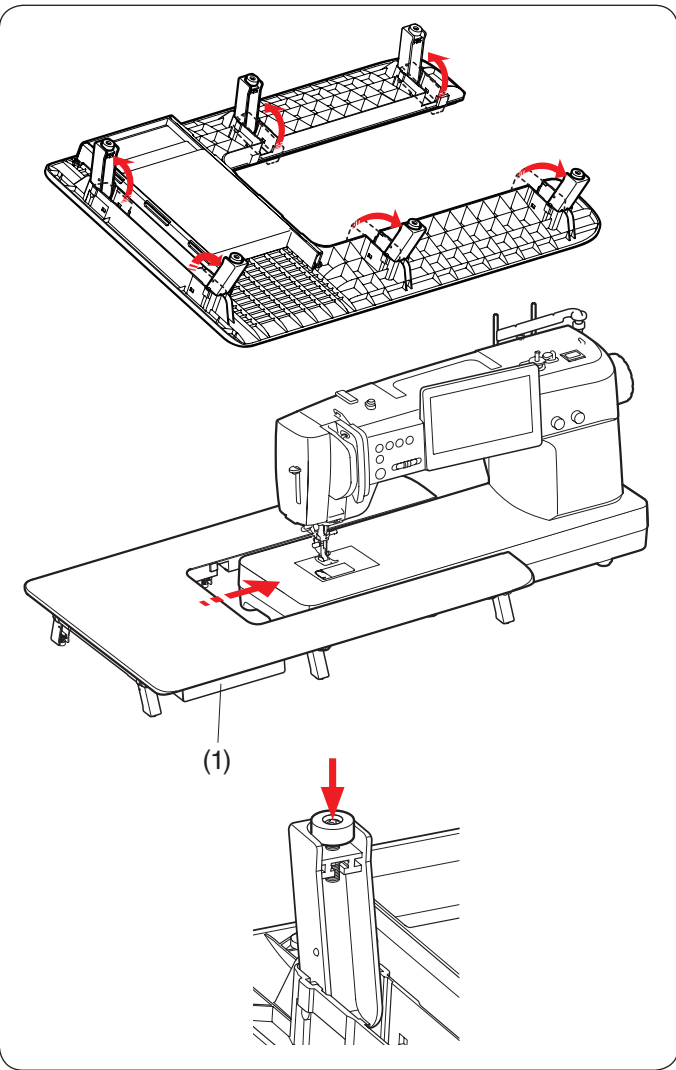

Extra Wide Table

Attaching the table

Spread the legs of extra wide table.

Holding the table with both hands and slide it gently to the right.

⚠ CAUTION:

Make sure there should be no accessory stored in the drawer when leaning the extra wide table against any wall.

If the accessories are stored into the drawer, the accessories stored inside of the drawer may be messed up and accessories may be stuck between the table and the drawer, or accessories and the drawer may fall off from the extra wide table.

(1) Drawer

Adjusting the table height

Turn setscrews of the table legs with a Phillips head screwdriver.

NOTE:

A Phillips head screwdriver is required for adjusting the extra wide table height.

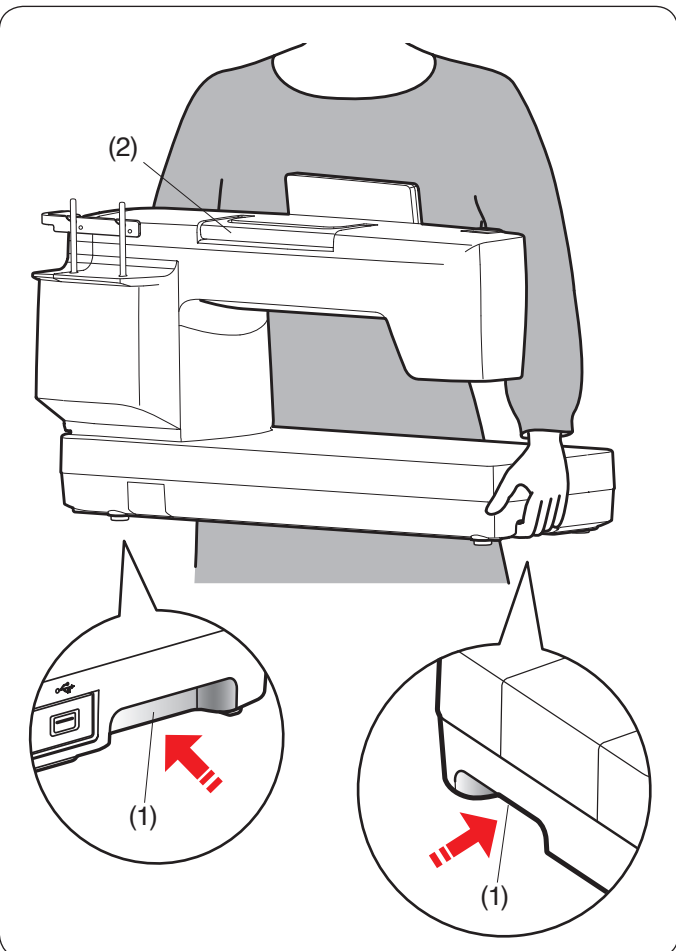

How to Carry the Sewing Machine

When carrying the sewing machine, hold the lower carrying handles with both hands.

Do not push the visual touch screen with your body.

(1) Carrying handle (lower)

NOTE:

Use the carrying handle (upper) for a supportive purpose.

(2) Carrying handle (upper)

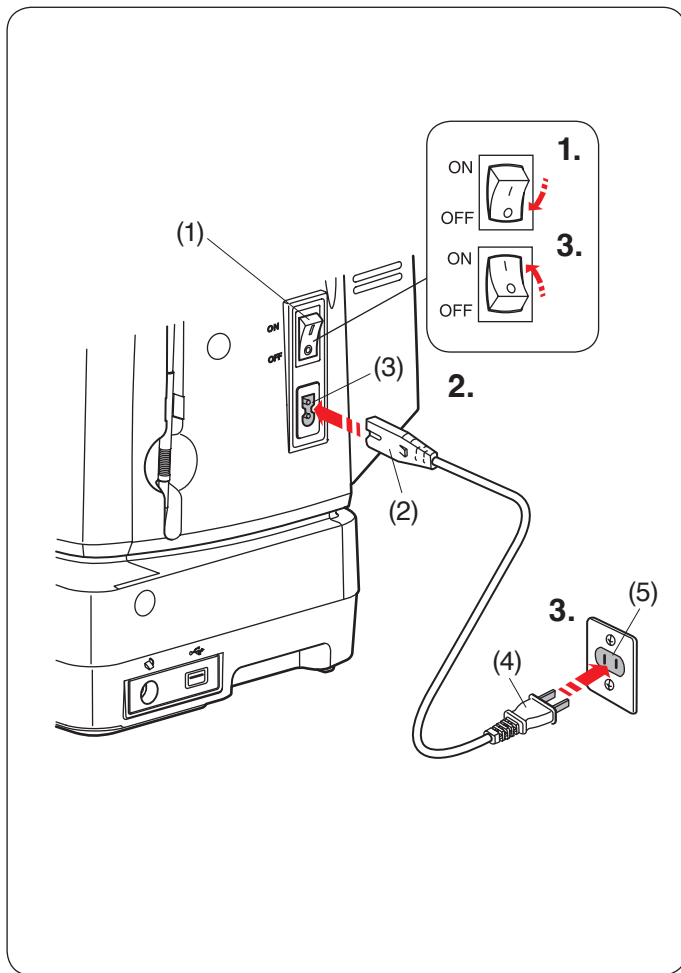

GETTING READY TO SEW

Connecting the Power Supply

Using Start/Stop Button

1. First make sure the power switch is off.
2. Insert the machine plug of the power supply cable into the machine socket.
3. Insert the power supply plug into the wall outlet, and turn the power switch on.

- (1) Power switch
- (2) Machine plug
- (3) Machine socket
- (4) Power supply plug
- (5) Wall outlet

NOTE:

- Make sure to use the power supply cable that came with the machine.
- If you turn off the power switch, wait for 5 seconds before turning it on again.



WARNING:

While in operation, always keep your eyes on the sewing area, and do not touch any moving parts such as the thread take-up lever, handwheel or needle. Always turn off the power switch and unplug the machine from the power supply:

- when leaving the machine unattended.
- when attaching or removing parts.
- when cleaning the machine.

Do not place any objects on the foot control.

Before Using Your Sewing Machine

Before using your sewing machine for the first time, place an extra piece of fabric under the presser foot and run the machine for a few minutes.

Wipe away any oil which may appear.

Operating Instructions:

The symbol "O" on the switch indicates the "off" position of the switch.

For the U.S.A. and Canada only

Polarized plug (one blade wider than the other):

To reduce the risk of electric shock, this plug is intended to fit in a polarized outlet only one way. If it does not fit fully in the outlet, reverse the plug. If it still does not fit, contact a qualified electrician to install the proper outlet. Do not modify the plug in any way.

Using Foot Control

If you wish to use the foot control, pull out the cord from the foot control and insert the pin connector into the jack on the machine.

1. First make sure the power switch is off.
2. Insert the machine plug of the power supply cable into the machine socket.
3. Draw out the cord from the foot control and insert the pin connector into the foot control jack on the machine.
4. Insert the power supply plug into the wall outlet, and turn the power switch on.

- (1) Power switch
- (2) Machine plug
- (3) Machine socket
- (4) Pin connector
- (5) Foot control jack
- (6) Power supply plug
- (7) Wall outlet

NOTE:

The start/stop button does not work when the foot control is connected.

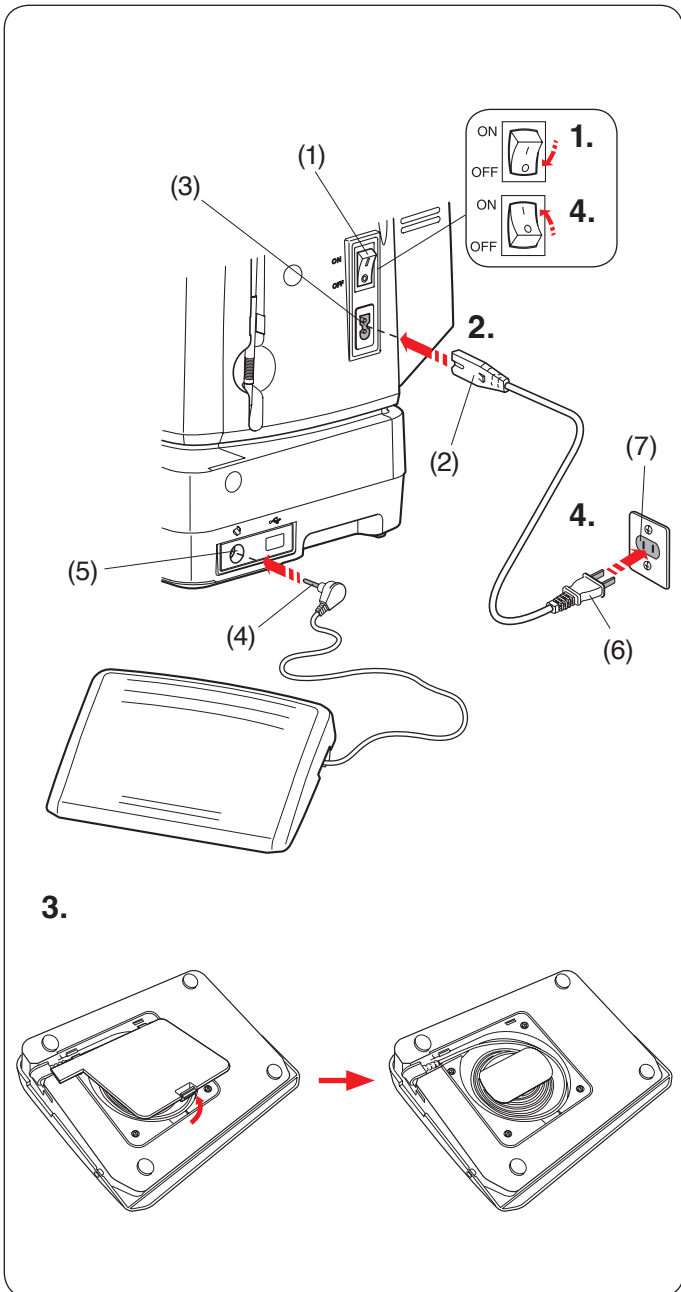

Cord storage

The cord of the foot control can be conveniently stored in the cord storage under the base cover of the foot control.

- (1) Base cover
- (2) Cord
- (3) Hooks

Operating Instructions:

Foot control model 21390 is for use with this sewing machine.

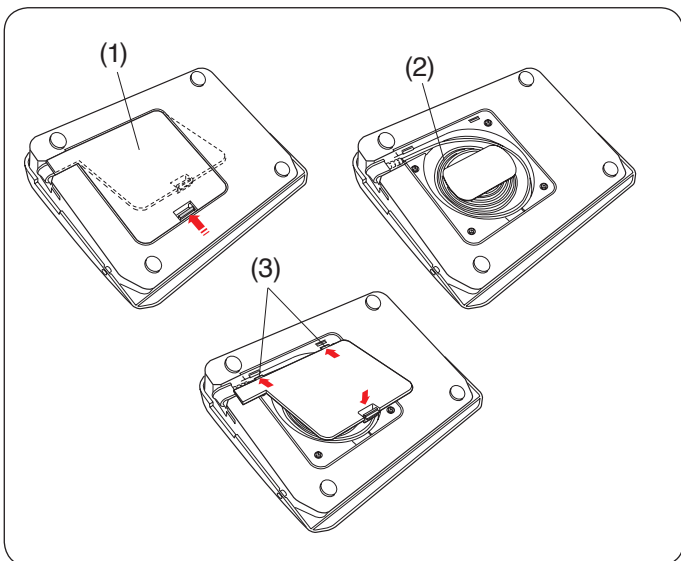

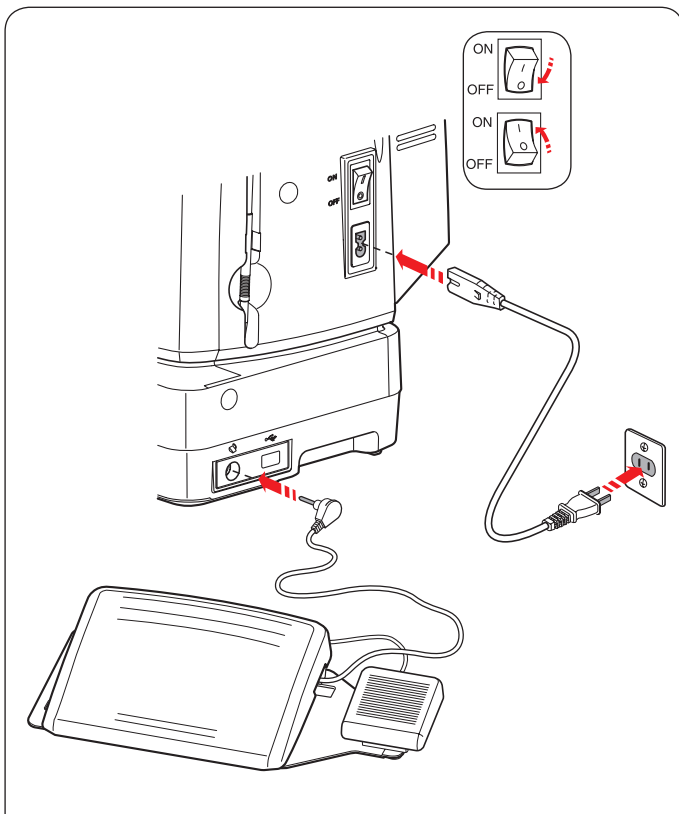

Thread Cutter Switch

If you wish to use the thread cutter switch, pull out the cord from the foot control and insert the pin connector into the jack on the machine.

1.

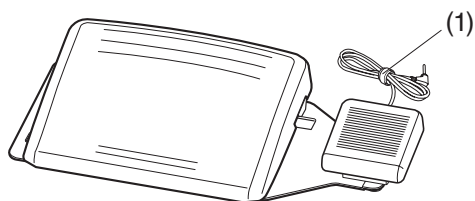

2.

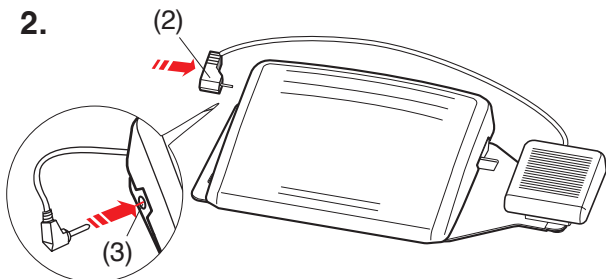

3.

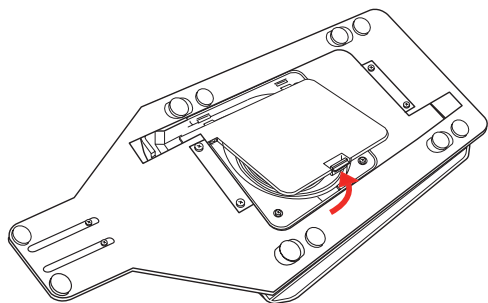

4.

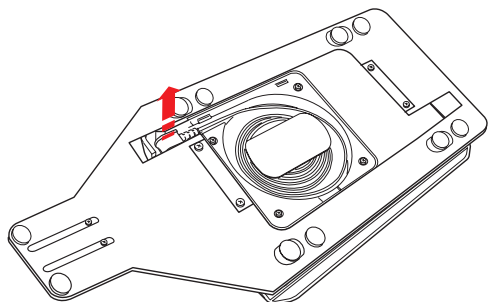

Preparation for Thread Cutter Switch

1. Remove the cable tie from the cable.

(1) Cable tie

2. If you wish to use the thread cutter switch, you need to connect it with the foot control.

Insert the pin connector into the jack on the foot control.

(2) Pin connector

(3) Jack

3. Turn the foot control upside down.

Open the cover of the foot control.

4. Draw out the cable from the foot control.

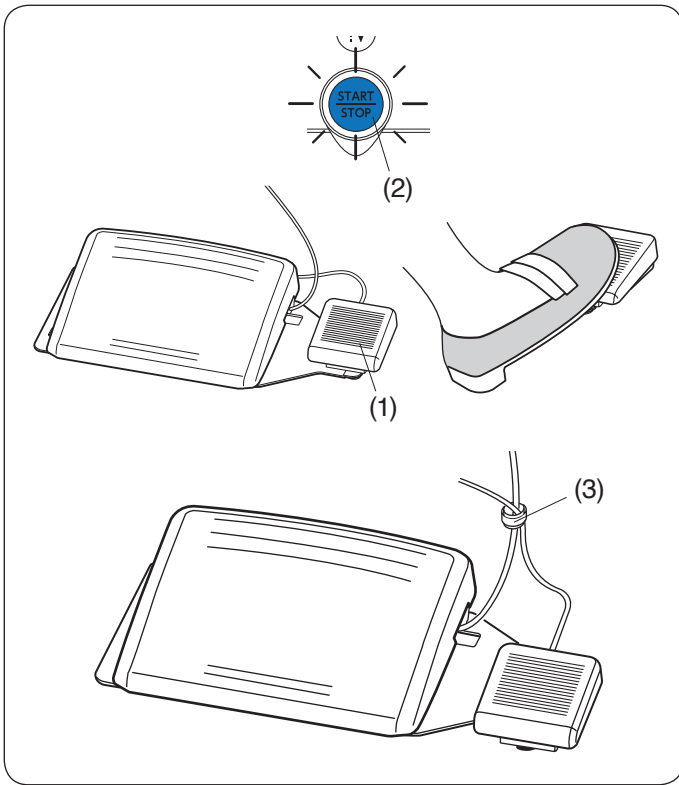

After sewing, depress the thread cutter switch on the right side of the foot control to trim both the needle and bobbin threads.

Do not depress the thread cutter switch until the start/stop button turns blue (2).

(1) Thread cutter switch

NOTE:

- Threads are trimmed when the thread cutter switch is depressed for more than 0.5 seconds.
- The thread cutter switch does not work without the foot control being depressed first.
- Bundle the cables with the cable tie as necessary.

(3) Cable tie

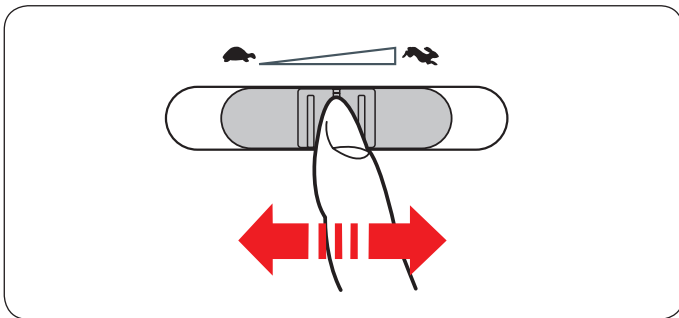

Controlling Sewing Speed

Speed Control Slider

You can limit the maximum sewing speed with the speed control slider according to your sewing needs.

To increase the sewing speed, move the slider to the right. To decrease the sewing speed, move the slider to the left.

The sewing speed can be changed while stitching.

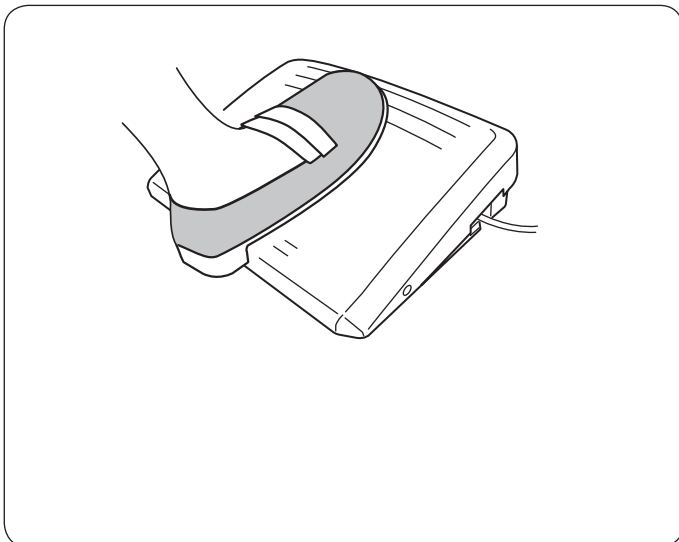

Foot Control

Pressing on the foot control can vary sewing speed.

The harder you press the foot control, the faster the machine runs.

NOTE:

- The machine runs at the maximum speed set by the speed control slider when the foot control is fully depressed.
- You can select the desired start-up speed from slow, medium or high (refer to page 140).

NOTE:

This machine is equipped with an automatic shutdown safety feature to prevent overheating whenever the machine is running overloaded. Follow the safety instructions that appear on the visual touch screen.

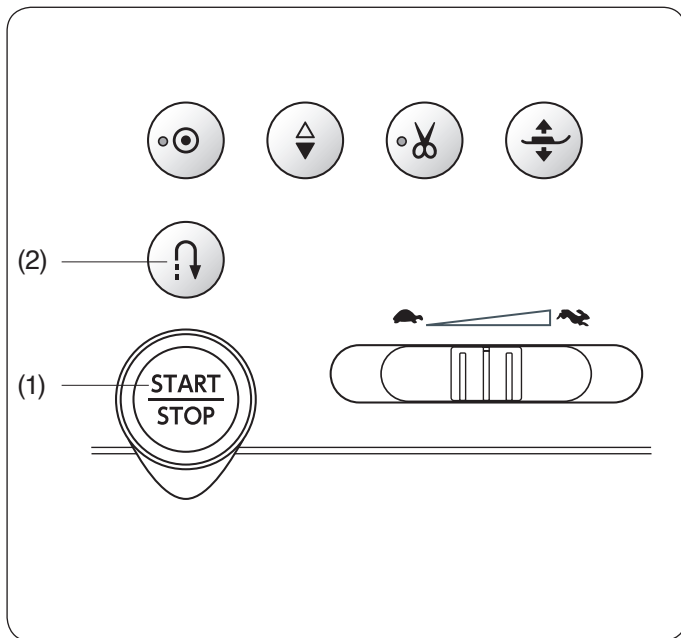

Machine Operating Buttons

(1) Start/stop button

Press this button to start or stop the machine.

The machine starts running slowly for the first few stitches, then runs at the speed set by the speed control slider. The machine runs slowly as long as this button is pressed.

The button will turn red when the machine is running, and blue when it has been stopped.

Pressing and holding this button while sewing will slow down the sewing speed and the machine will stop when the button is released.

NOTE:

- The start/stop button cannot be used when the foot control is connected to the machine.
- You can select the desired start-up speed from slow, medium or high (refer to page 140).

(2) Reverse button

- **When the following stitch patterns are selected:**

Utility	Applique	Quilt	Bridge

The machine will sew in reverse as long as the reverse button is pressed. Release the button to sew forward.

When the machine is stopped and foot control is disconnected, the machine will sew in reverse slowly as long as the reverse button is pressed.

Release the button to stop the machine.

- **When the following stitch patterns are selected:**

Utility	Buttonhole

There will be particular functions of the reverse button when the patterns shown above are selected. Refer to pages 41, 62-63, 68 and 120 for instructions.

- **When any other stitches are selected:**

If you press the reverse button when sewing any other patterns, the machine will immediately sew locking stitches and automatically stop.

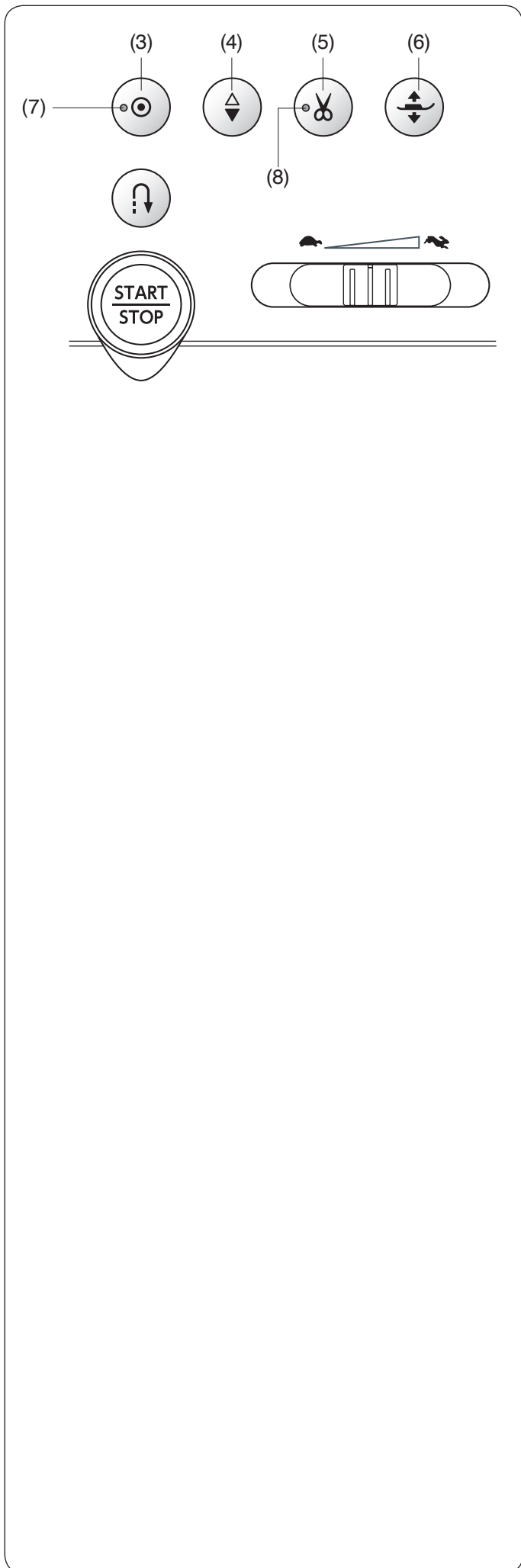

(3) Auto-lock button

• When the following stitch patterns are selected:

Utility	Applique	Quilt	Bridge

Press the auto-lock button to sew a locking stitch immediately. The machine will automatically stop.

When the machine is stopped, press the auto-lock button and the LED signal (7) will blink. The machine will immediately sew locking stitches and automatically stop when the machine is started.

• When any other stitches are selected:

Press the auto-lock button to sew a locking stitch at the end of the current pattern. The machine will automatically stop.

When the machine is stopped, press the auto-lock button and the LED signal (7) will blink. The machine will sew a locking stitch at the end of the current pattern and automatically stop when the machine is started.

The machine will trim the threads automatically after locking the stitch when the auto thread cutting is turned on (refer to page 139).

(4) Needle up/down button

Press this button to bring the needle bar up or down. The machine will stop with the needle in the down position.

However, you can change the needle stop position in the machine setting mode (refer to page 139).

(5) Thread cutter button

After finishing sewing, press this button to trim the threads. The needle bar automatically rises after trimming the threads (refer to page 40).

The LED signal (8) blinks when the machine trims threads.

After using auto thread cutting or threading the bobbin holder, you can start sewing without drawing up the bobbin thread.

NOTE:

The thread cutter button does not function:

- directly after turning on the power.
- when the presser foot is raised with the presser foot lifter.
- after being pressed 3 times in a row.

Use the thread cutter on the face plate if the thread is #30 or thicker (refer to page 40).

(6) Presser foot lifter button

The presser foot will go up or down by pressing this button.

You can also use the presser foot lifter and knee lifter to raise and lower the presser foot (refer to page 20).

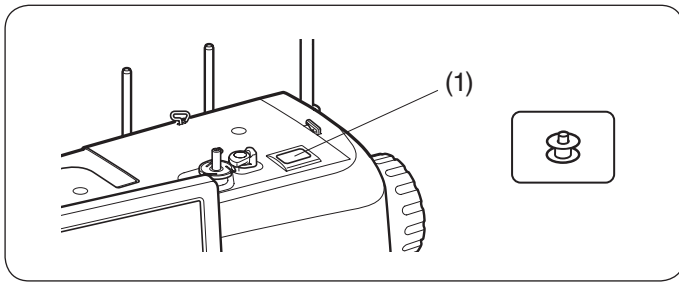

Bobbin Winding Button and Jog Dials

(1) Bobbin winding button (refer to page 28)

Press this button to wind the bobbin.

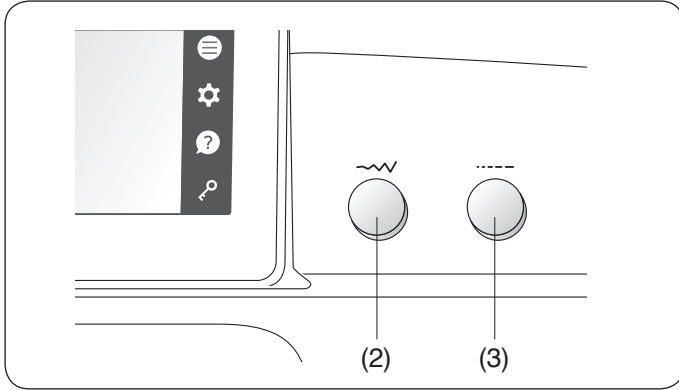

(2) Stitch width adjusting dial (refer to pages 48, 49, 60, 68, etc.)

Turn this jog dial to alter the stitch width or needle drop position of the selected stitch pattern.

(3) Stitch length adjusting dial (refer to pages 48, 49, 60, 68, etc.)

Turn this jog dial to alter the stitch length of the selected pattern.

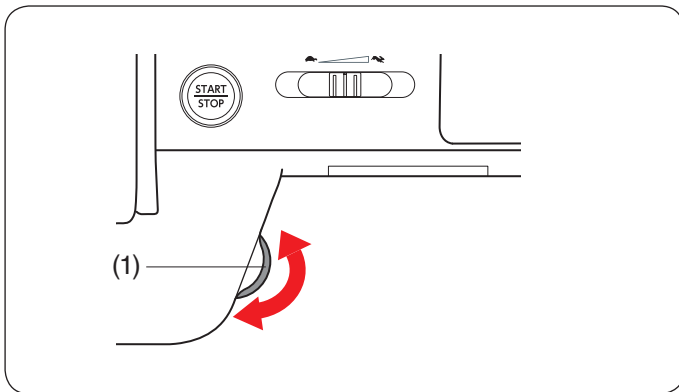

Thumb Wheel

Turn the thumb wheel to lower or raise the needle to check the needle drop position.

- (1) Thumb wheel

NOTE:

Do not use the thumb wheel to penetrate the fabric.

Touch Panel Keys

CAUTION:

Do not press the touch panel or visual touch screen with hard or sharp objects like pencils, screwdrivers or the like. Use the touch panel stylus included in the standard accessories.

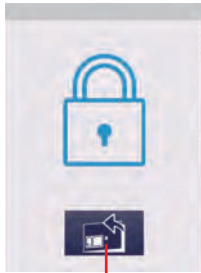
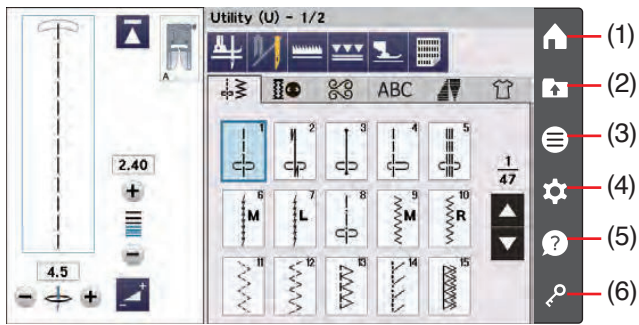

(7)

(1) Home key

Press this key to return the top of the utility stitch pattern selections.

(2) Open file key (refer to page 102)

Press this key and the open file window will open.

You can open pattern combinations and monograms saved in the machine's internal memory or on a USB flash drive.

(3) Function menu key (refer to page 133)

Press this key to open the function menu.

You can select the following functions from this menu.

- Quick Stitch Select
- Quilt Block Advisor
- Manual Dual Feed Setting
- Machine Information

(4) Set mode key (refer to page 136)

Press this key to enter the setting mode. You can customize the machine settings to your preference.

The settings for Machine Settings, Sewing Settings and Language Setting are available in this mode.

(5) Help key (refer to page 19)

Press this key to view the step-by-step visual guides about the essential operations.

(6) Lockout key

Press this key to lockout the machine when threading the machine, replacing the accessories etc.

To reduce the risk of injury, all the buttons and keys except the lockout key, needle plate release key (7) and presser foot lifter button are deactivated.

To unlock the machine, press this key again.

On-screen Help

Press the help key to open the help menu.

You can view instructions on 8 topics of essential operations of the machine.

Select the help topic by pressing the book key and the step-by-step instruction will open.

- (1) Help key
- (2) Book key

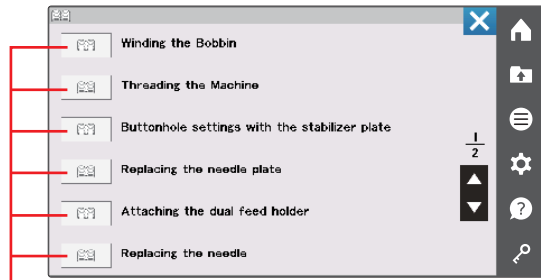
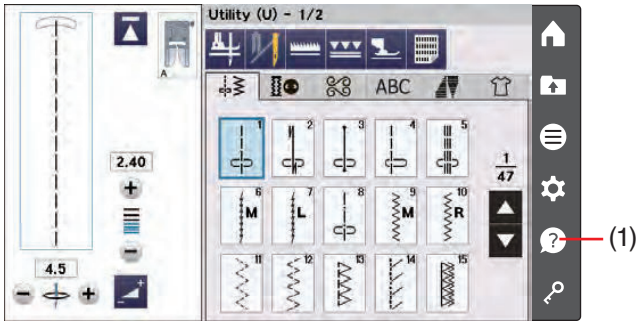

(2)

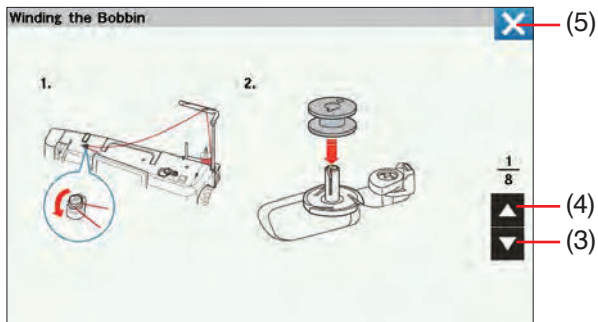

To view the next page, press the next page key.

To view the previous page, press the previous page key.

Press the X key to close the current window.

- (3) Next page key
- (4) Previous page key
- (5) X key

Raising and Lowering the Presser Foot

CAUTION:

Do not turn the handwheel or press the needle up/down button when the presser foot is in extra lifted position. It may cause damage to the presser foot.

The presser foot lifter button, the presser foot lifter or the knee lifter raises and lowers the presser foot.

You can raise the presser foot about 6 mm (1/4") higher than the normal up position by exerting more pressure when lifting the presser foot lifter or knee lifter. This helps you to place layers of thick fabric.

- (1) Presser foot lifter button
- (2) Presser foot lifter
- (3) Presser foot
- (4) Up position
- (5) Extra lifted position
- (6) Down position

NOTE:

The presser foot cannot be lowered with the presser foot lifter if the foot was raised with the presser foot lifter button.

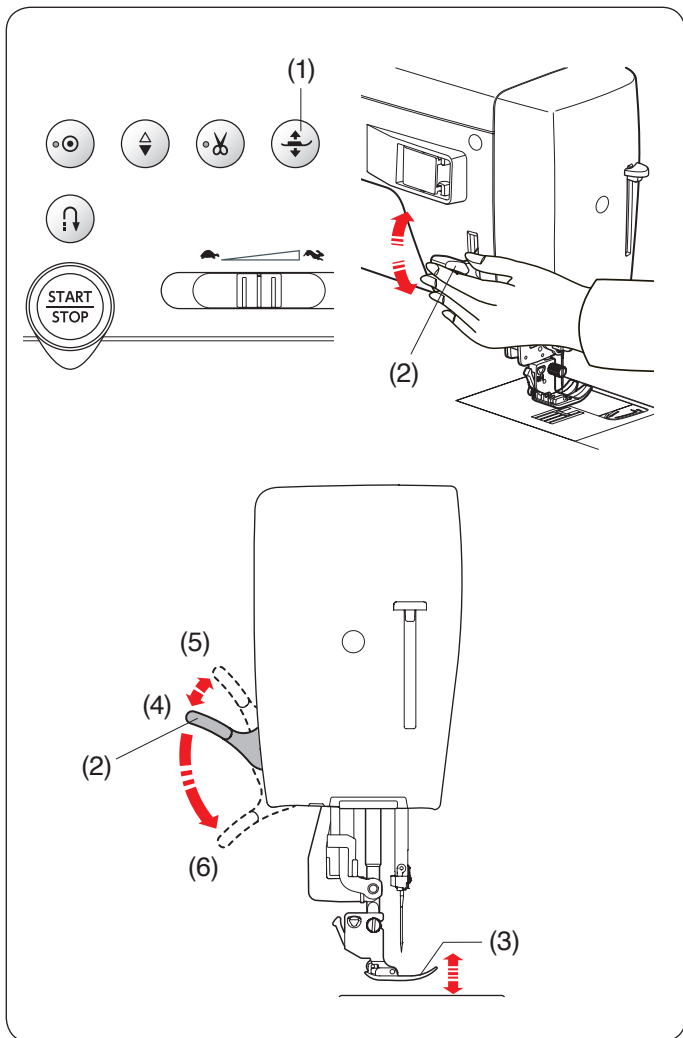

Knee Lifter

The knee lifter is extremely helpful when sewing patchwork, quilting etc., since it allows you to handle the fabric while your knee controls the presser foot.

Attaching the knee lifter

Match the ribs on the knee lifter with the notches in the knee lifter socket and insert the knee lifter.

- (1) Knee lifter
- (2) Rib
- (3) Knee lifter socket

Adjusting the knee lifter

The angle of the knee lifter can be adjusted to fit you. Loosen the setscrew and slide the angle bar in or out to adjust the angle of the knee lifter.

Tighten the setscrew to secure the angle bar.

- (4) Setscrew
- (5) Angle bar

Using the knee lifter

Push the knee lifter with your knee to easily move the presser foot up and down.

You can control how high the foot rises by the amount of knee pressure you exert.

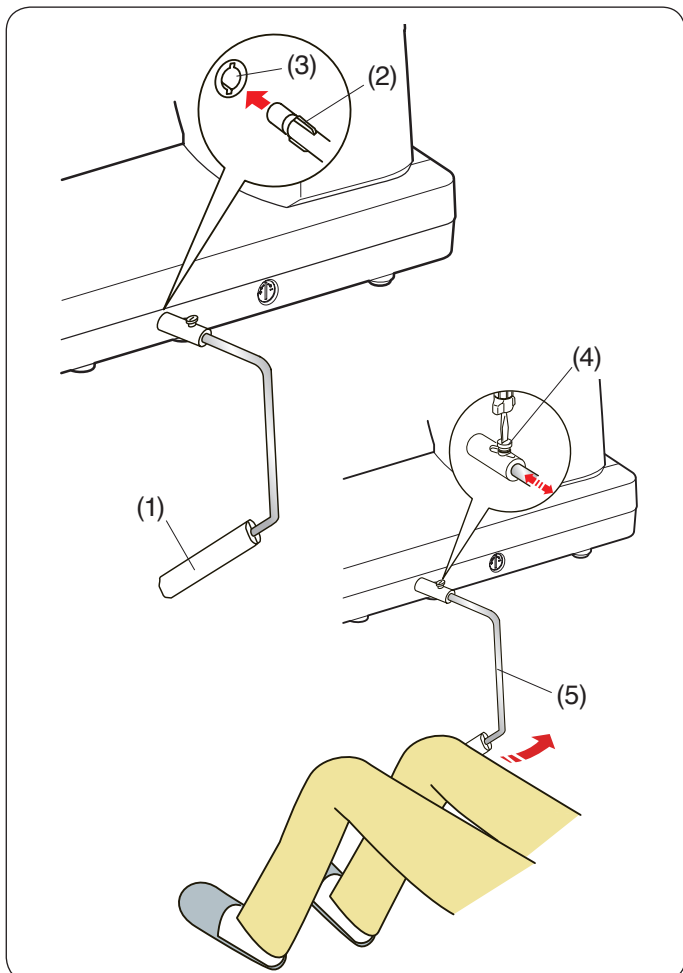

Replacing the Presser Foot

CAUTION:

Always make sure to press the lockout key to before replacing the presser foot.
Use the proper foot for the selected pattern.
The wrong foot can cause the needle to break.

1.

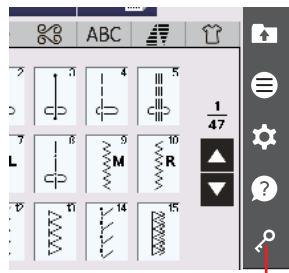

(2)

1. Raise the needle by pressing the needle up/down button.

Press the lockout key.

- (1) Needle up/down button
- (2) Lockout key

2. Raise the presser foot lifter.

- (3) Presser foot lifter

2.

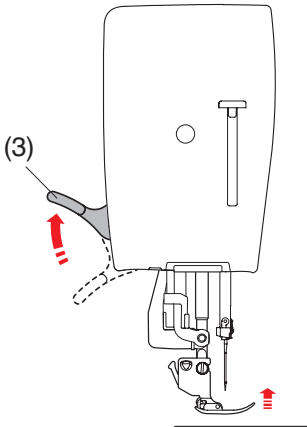

3.

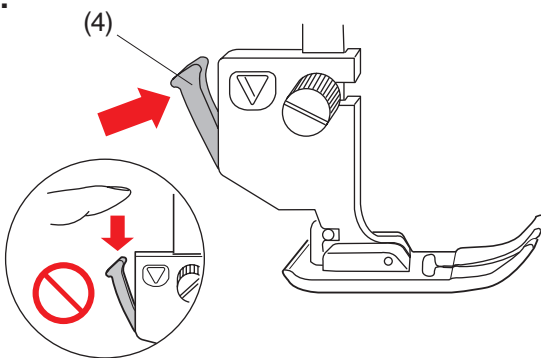

3. Press the black lever on the back of the foot holder.

The presser foot will drop off.

- (4) Lever

CAUTION:

To avoid damaging the lever, do not push it down.

4.

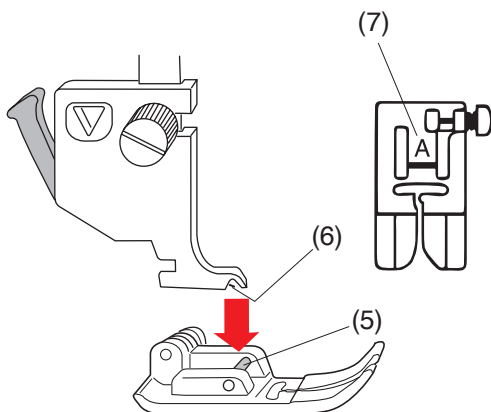

4. Place the presser foot so that the pin on the foot lies just under the groove of the foot holder.

Lower the presser foot lifter to lock the foot in place.

- (5) Pin
- (6) Groove

Each foot is marked with an identification letter.

- (7) Identification letter

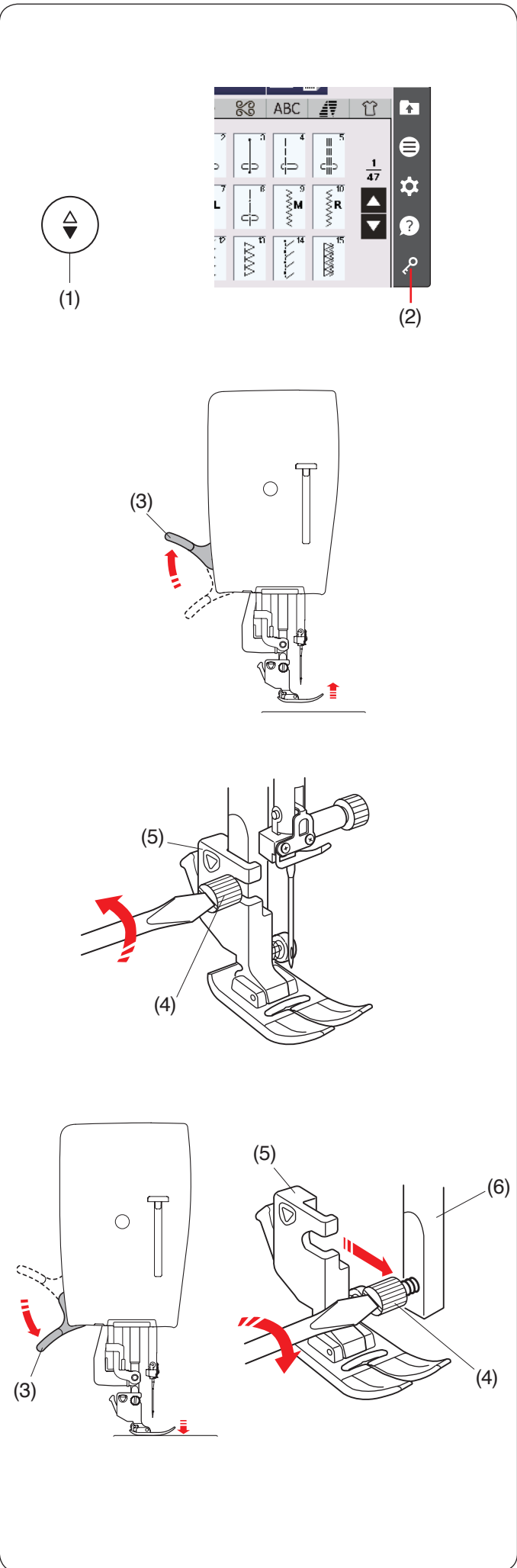

Removing and Attaching the Foot Holder

Remove the foot holder before using professional grade foot HP, ruler work foot QR, darning foot PD-H, or dual feed foot AD or A.S.R. (Accurate Stitch Regulator).

CAUTION:

Always make sure to press the lockout key to lockout the machine before replacing the foot holder.

Removing the foot holder

Raise the needle by pressing the needle up/down button. Press the lockout key and raise the presser foot with the presser foot lifter.

- (1) Needle up/down button
- (2) Lockout key
- (3) Presser foot lifter

Loosen the thumbscrew and remove the foot holder.

- (4) Thumbscrew
- (5) Foot holder

Attaching the foot holder

Attach the foot holder to the presser bar from the rear. Lower the presser foot with the presser foot lifter. Tighten the thumbscrew securely with the screwdriver.

- (6) Presser bar

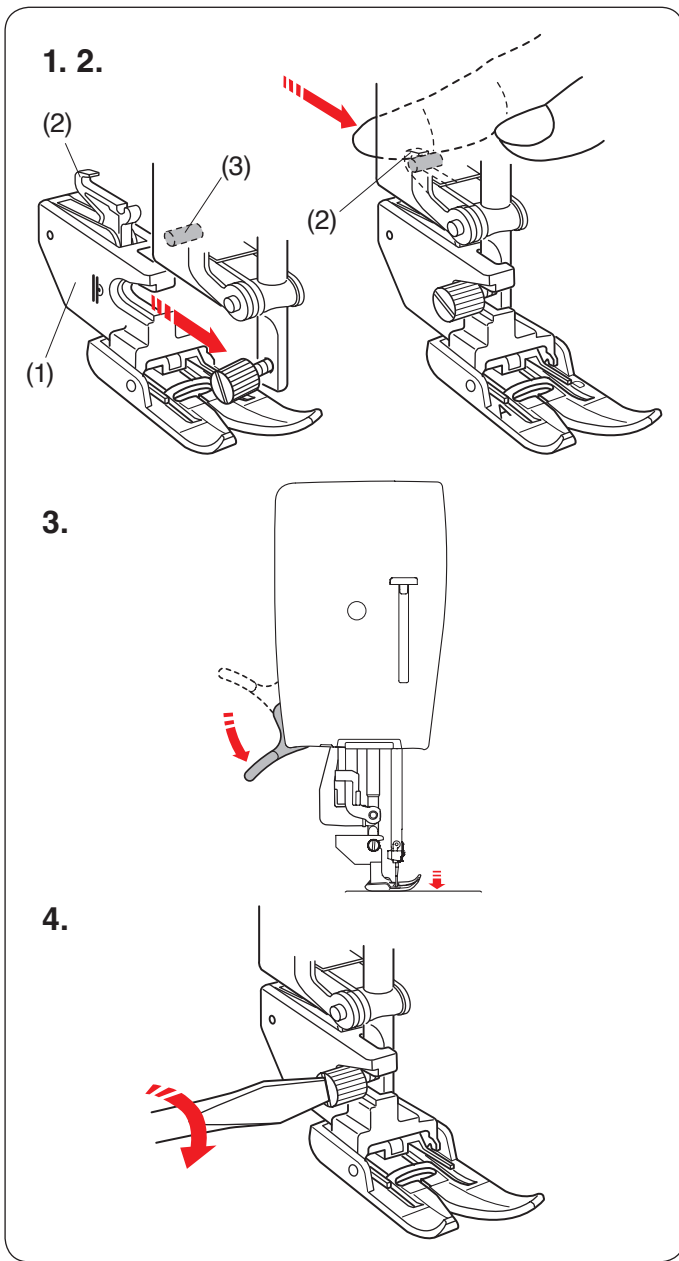

Attaching Dual Feed Foot AD or Dual Feed Plus Professional Foot HP2

1. Attach the dual feed holder to the presser bar from behind.
 - (1) Dual feed holder
2. Tighten the thumbscrew with your fingers. Push the dual feed link to engage it with upper feed drive.
 - (2) Dual feed link
 - (3) Upper feed drive
3. Lower the presser foot lifter. Lower the needle to the lowest position by turning the handwheel.
4. Tighten the thumbscrew securely with the screwdriver.

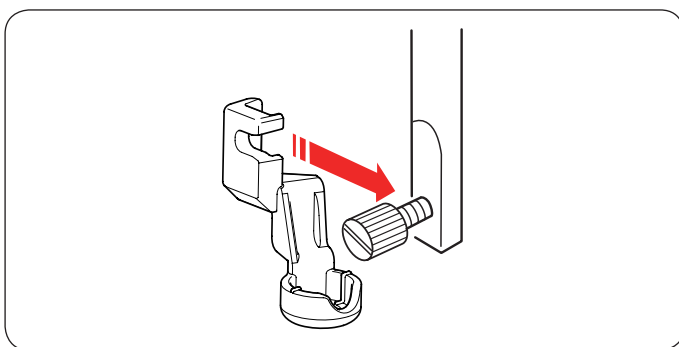

Attaching the Ruler Work Foot QR

Attach the ruler work foot QR to the presser bar from behind. Tighten the thumbscrew firmly with the screwdriver.

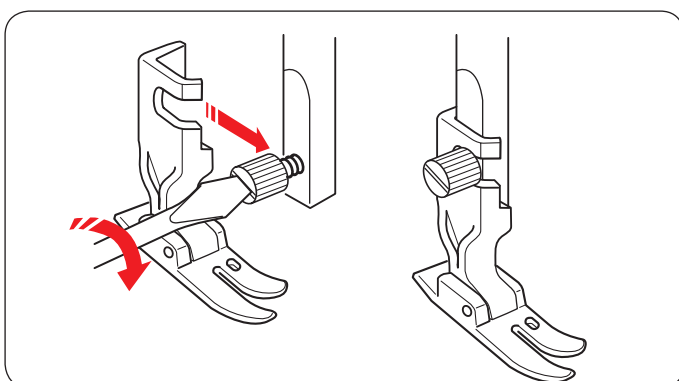

Attaching the Professional Grade Foot HP

Attach the professional grade foot HP to the presser bar from behind. Lower the presser foot with the presser foot lifter. Tighten the thumbscrew firmly with the screwdriver.

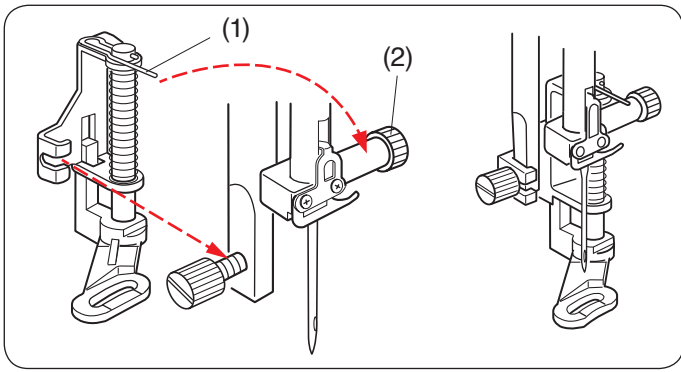

Attaching the Darning Foot PD-H or the Darning Foot PD-H (open-toe)

Attach the darning foot PD-H or the darning foot PD-H (open-toe) to the presser bar by putting the pin on the needle clamp screw.

- (1) Pin
- (2) Needle clamp screw

Tighten the thumbscrew firmly with the screwdriver.

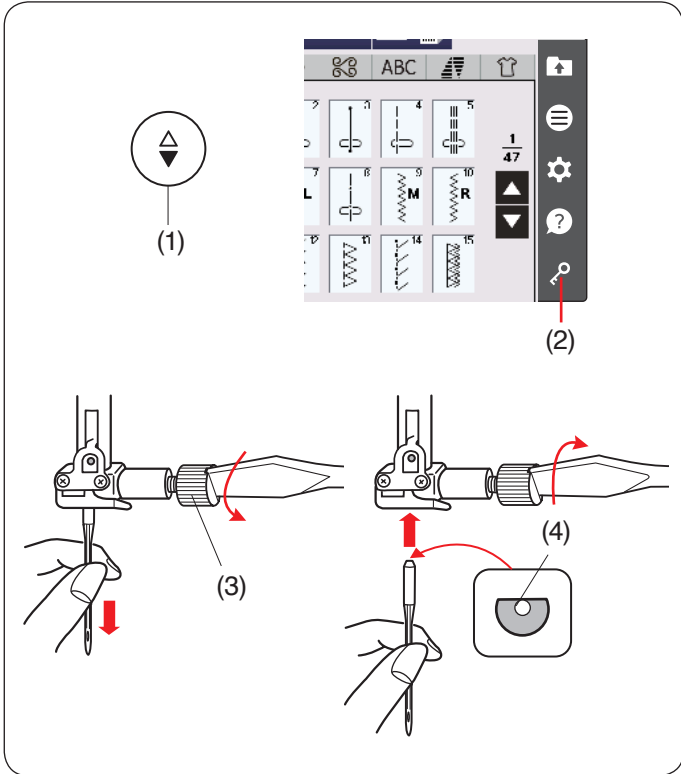

Replacing Needles

CAUTION:

Always make sure to press the lockout key to lockout the machine before replacing the needle.

Raise the needle by pressing the needle up/down button. Press the lockout key.

- (1) Needle up/down button
- (2) Lockout key

Loosen the needle clamp screw by turning it counterclockwise.

Remove the needle from the clamp.

- (3) Needle clamp screw

Insert a new needle into the needle clamp with the flat side of the needle to the rear.

- (4) Flat side

When inserting the needle into the needle clamp, push it up against the stopper pin and tighten the needle clamp screw firmly with a screwdriver.

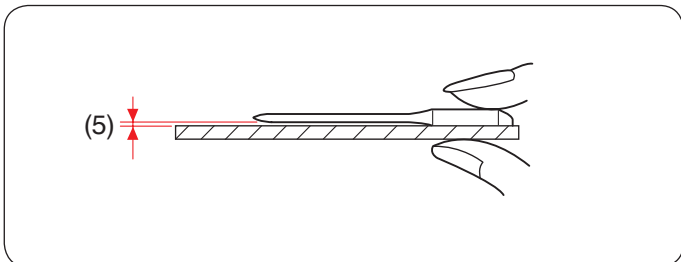

To check needle straightness, place the flat side of the needle onto something flat (a needle plate, glass etc.). The gap between the needle and the flat surface should be consistent.

- (5) Gap

Never use a blunt needle.

CAUTION:

Be sure to tighten the needle clamp screw firmly with a screwdriver when attaching a needle to the machine, otherwise the needle may break or cause malfunction.

Fabric		Thread	Needle
Fine	Lawn	Cotton #80-100 Synthetic #80-100	Blue tip needle Universal needle #9/65-11/75
	Georgette		
	Tricot		
	Organza		
	Crepe		
Medium	Sheeting	Cotton #50-80 Synthetic #50-80	Red tip needle Purple tip needle Universal needle #11/75-14/90
	Jersey		
	Broadcloth		
	Fleece		
Heavy weight	Denim	Cotton #40-50 Synthetic #40-50	Red tip needle Purple tip needle Universal needle #14/90-16/100
	Tweed		
	Coating		
	Quilting		

Fabric and Needle Chart

- For general sewing, use red tip needle.
- Fine threads and needles should be used for sewing fine fabrics.
- In general, use the same thread for both needle and bobbin.
- Use a blue tip needle for sewing fine fabrics, stretch fabrics, tricot and buttonholes to prevent skipped stitches.
- Use a purple tip needle for sewing knits, free quilting and across the hem to prevent skipped stitches.
- Use a stabilizer or interfacing for stretch or fine fabrics to prevent seam puckering.
- Always test the thread and needle size on a small piece of the same fabric you will use for actual sewing.

NOTE:

1 x twin needle, 2 x blue tip needle (#11/75), 1 x red tip needle (#14/90) and 1 x purple tip needle (#14/90) are included in the needle case (Part No. 859856005).

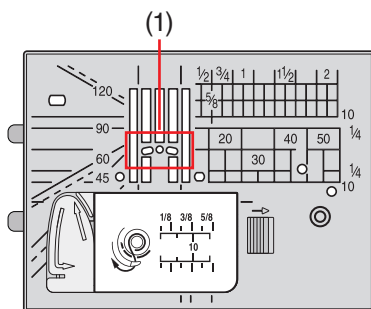

Using the Straight Stitch Needle Plate

The straight stitch needle plate has three holes where the needle enters. The straight stitch needle plate is helpful to hold and support the fabric when the needle pierces the fabric. Use the straight stitch needle plate for better results.

- (1) Three holes

It is recommended to use straight stitch needle plate to select patterns U1 to U3 when sewing straight stitches. Refer to page 34 for how to attach the straight stitch needle plate.

NOTE:

The patterns not suitable for the straight stitch needle plate are grayed out.

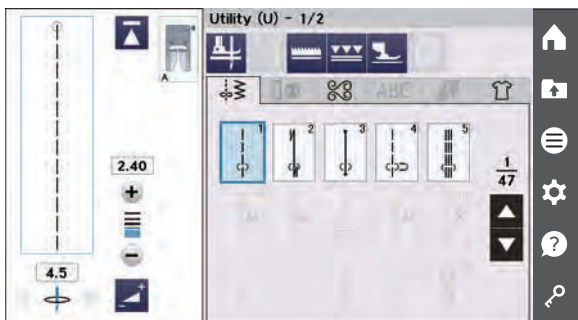

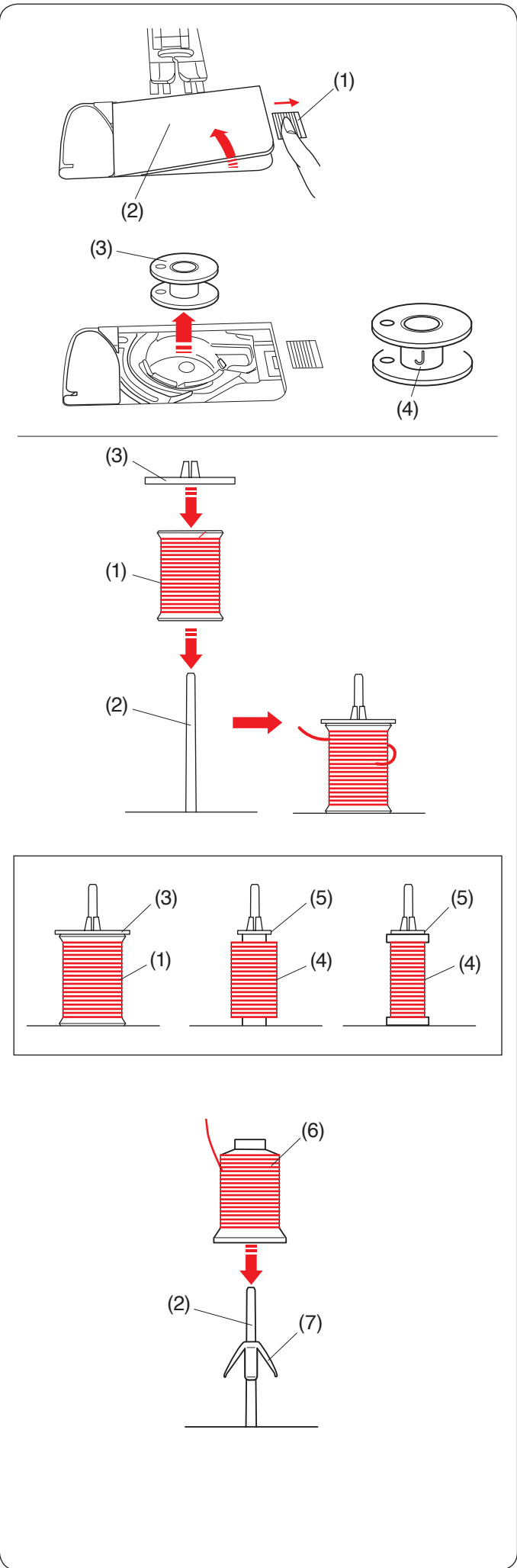

Winding the Bobbin

Removing the bobbin

Press the lockout key. Slide the hook cover release button to the right, and remove the hook cover plate.

- (1) Hook cover release button
- (2) Hook cover plate

Lift out the bobbin from the bobbin holder.

- (3) Bobbin

NOTE:

- Use "J" plastic bobbins (4) for the horizontal hook. Using other bobbins, such as pre-wound paper bobbins, may cause stitching problems and/or damage to the bobbin holder.
- Do not use the easy bobbins or metal bobbins.

Setting the spool of thread

Place the spool of thread on the spool pin with the thread coming off the spool as shown.

Attach the spool holder, and press it firmly against the spool of thread.

- (1) Spool of thread
- (2) Spool pin
- (3) Spool holder (large)

Use the spool holder (large) for ordinary spools, and the spool holder (small) for small spools.

- (4) Small spool
- (5) Spool holder (small)

NOTE:

Avoid using a paper cored spool when it begins to empty since it will not unwind smoothly. It may cause the thread to bunch or slip when using the auto thread cutter.

Setting the thread cone

Use the spool rest and the spool net for thread cones.

Attach the spool rest on the spool pin.

Place the thread cone on the spool pin.

- (2) Spool pin
- (6) Thread cone
- (7) Spool rest

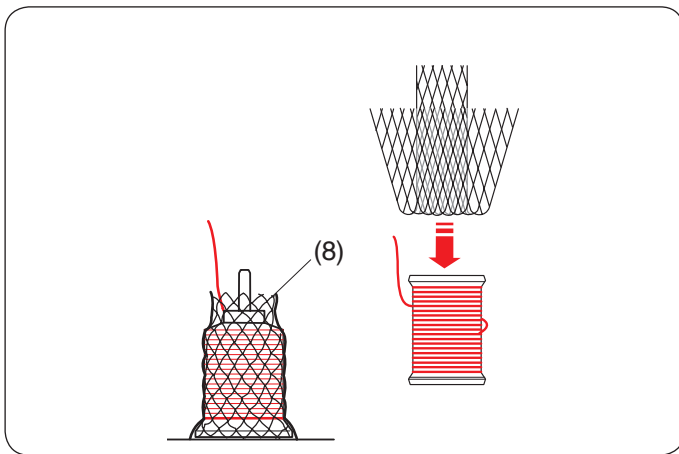

Setting the spool net

Cover the thread cone with the spool net if the thread is shaky or kinky when sewing.

If the net is too long for a spool, fold the net and place it on the spool.

(8) Spool net

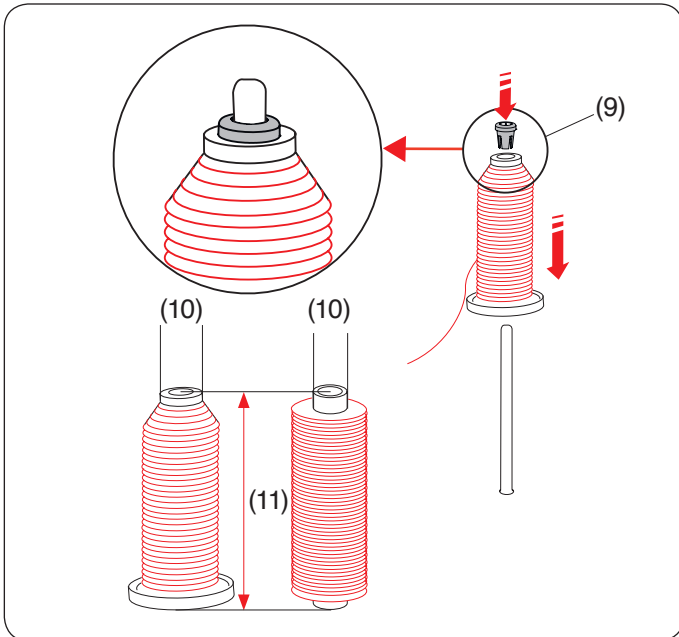

Setting the spool of thread or thread cone (special size)

Use the spool holder (special) to hold the specific size of the spool of threads as shown.

The sizes of the spools of thread are as follows; The hole diameter of the spool has a range of 3/8" to 7/16" (9.5 mm to 10.5 mm), and the spool length has a range of 2 3/4" to 3" (70 mm to 75 mm).

(9) Spool holder (special)

(10) Hole diameter (3/8" to 7/16")

(11) Spool length (2 3/4" to 3")

Firmly insert the spool holder (special) into the hole and hold the spool as illustrated.

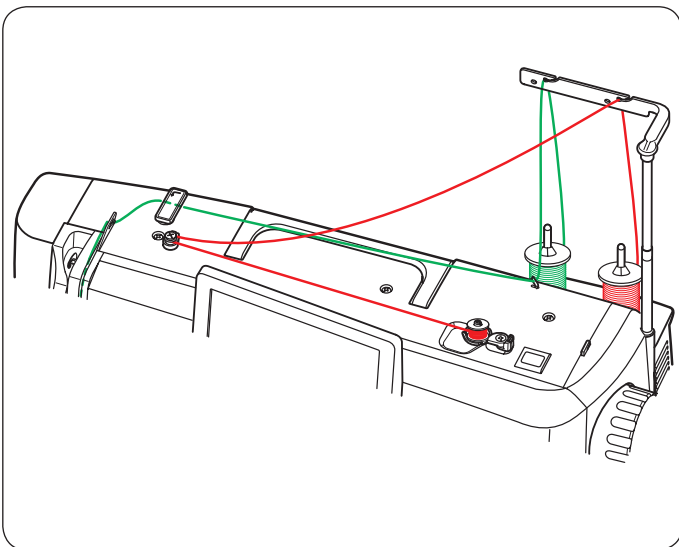

Bobbin winding while working on a sewing project

There are 2 spool pins on the spool stand.

You can use both spool pins when you need to wind a bobbin without unthreading the machine while working on a sewing project.

Place a spool of thread on the spool pin and fix the spool with the spool holder as shown.

NOTE:

Those spool pins are also used for twin needle sewing (refer to page 85).

Winding the bobbin

NOTE:

You can adjust the bobbin winding speed (refer to page 137).

1. Raise the retractable thread guide bar.
Pass the thread through the guide on the thread guide bar from behind.
(1) Thread guide bar
2. Pass the thread under the bobbin winding tension disk.
(2) Bobbin winding tension disk
3. Put the bobbin on the bobbin winder spindle.
Be sure that the bobbin snaps into the place.
(3) Bobbin
(4) Bobbin winder spindle
(5) Slit
(6) Spring (Projection)
4. Pass the thread to the bobbin.
Hold the thread with both hands and wind it around the bobbin clockwise several times.
5. Insert the thread into one of the slits of the flange plate and pull the thread to cut.
(7) Flange plate
(8) Slit
6. Push the bobbin winder stopper to the left.
(9) Bobbin winder stopper
7. Press the bobbin winding button. The visual touch screen will show the bobbin winding sign.
(10) Bobbin winding button
When the bobbin is fully wound, it will stop spinning and the bobbin stopper returns to its original position automatically.
8. Remove the bobbin. Cut the thread with the bobbin thread cutter.
(11) Bobbin thread cutter

NOTE:

For safety purposes, the machine will automatically stop 1.5 minutes after starting bobbin winding.

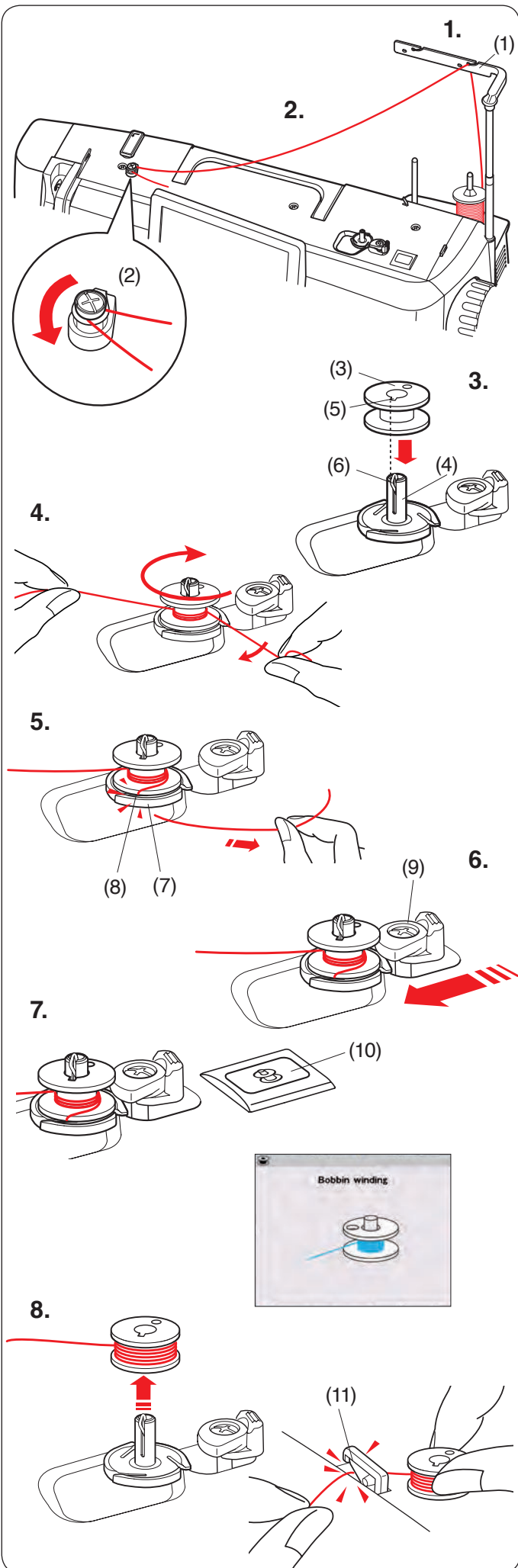

1.

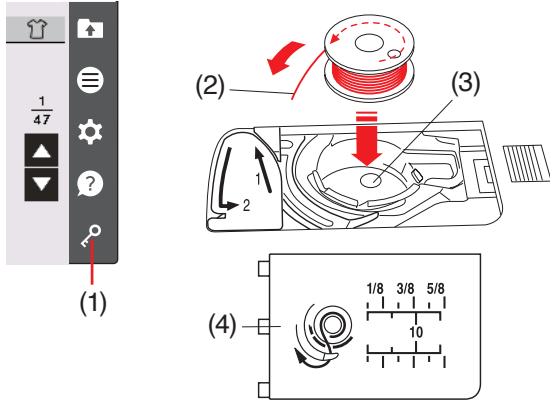

2.

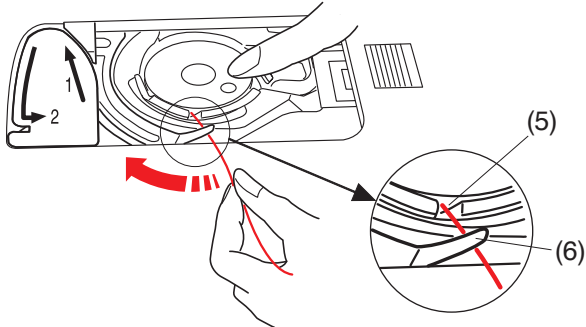

3.

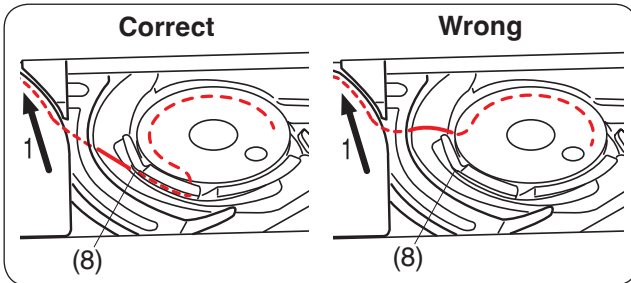
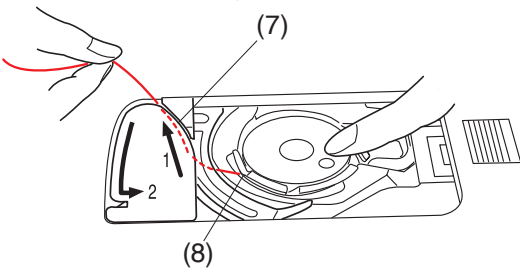

4.

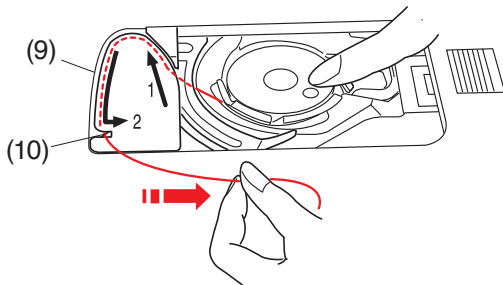

5.

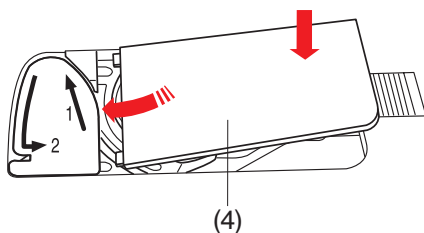

Inserting the Bobbin

1. Press the lockout key.

Place the bobbin in the bobbin holder with the thread running off counterclockwise as shown on the hook cover plate.

- (1) Lockout key
- (2) End of thread
- (3) Bobbin holder
- (4) Hook cover plate

2. Hold the bobbin with your fingertip so it does not rotate.

Guide the thread into the front notch of the bobbin holder.

Pull the thread to the left to pass it under the guide.

- (5) Front notch
- (6) Guide

3. Draw the thread to the left to pass it into the guide path marked "1".

Make sure that the thread comes out from the side notch of the bobbin holder.

- (7) Guide path 1
- (8) Side notch

NOTE:

If the thread does not come out from the side notch, rethread from step 1.

4. Continue to draw the thread along the guide path marked "2" and pull the thread to the right through the slit. The thread will be cut to a proper length and held in place.

- (9) Guide path 2
- (10) Slit (Thread cutter)

5. Set the left edge of the hook cover plate into the opening.

Push the hook cover plate down to fit in place.

NOTE:

Unless otherwise noted, you can start sewing without drawing up the bobbin thread. Refer to page 33 for how to draw up the bobbin thread.

Threading the Machine



CAUTION:

Always make sure to press the lockout key to lockout the machine before threading the machine.

1. Press the needle up/down button to raise the take-up lever to the highest position.
Press the lockout key to lockout the machine.

- (1) Needle up/down button
- (2) Thread take-up lever
- (3) Lockout key

2. Raise the retractable thread guide bar. Pass the thread through the guide on the thread guide bar from behind.

- (4) Thread guide bar

3. Pass the thread through the right thread guide.

- (5) Right thread guide

4. Hold the thread with both hands as shown and slip it under the upper thread guide.

- (6) Upper thread guide

5. Draw the thread toward you and pass it into the left thread guide.

- (7) Left thread guide

6. Draw the thread down along the right channel and around the bottom of the thread guide plate. Pull the thread up along the left channel.

- (8) Right channel
- (9) Thread guide plate
- (10) Left channel

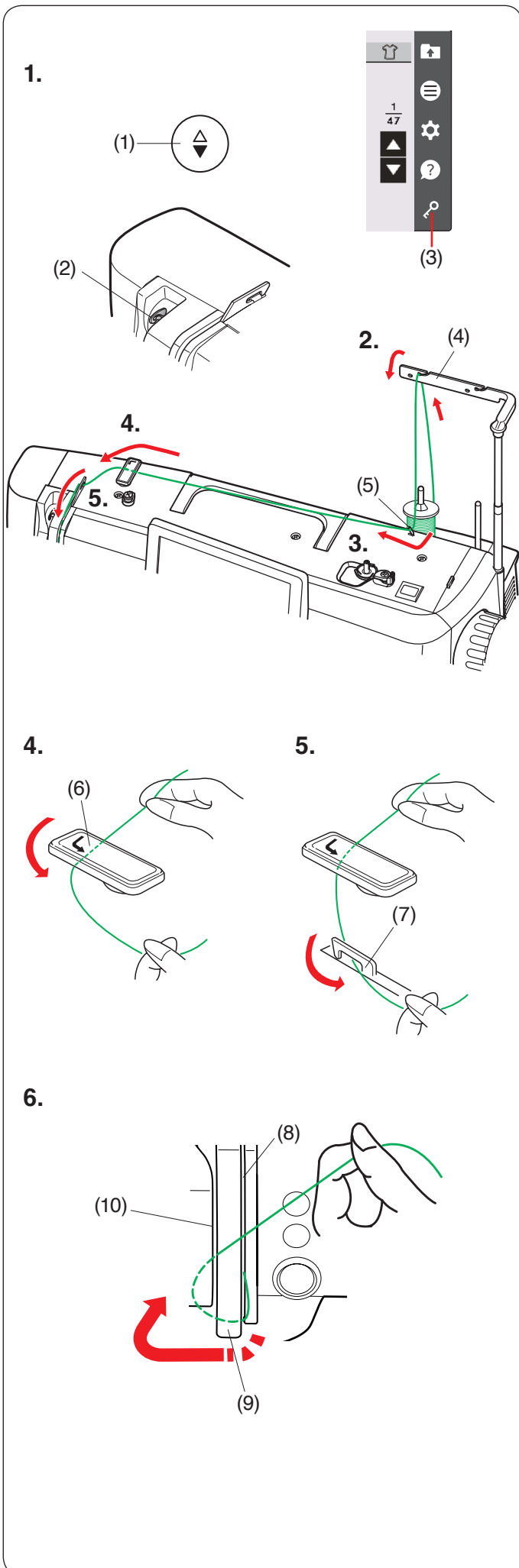

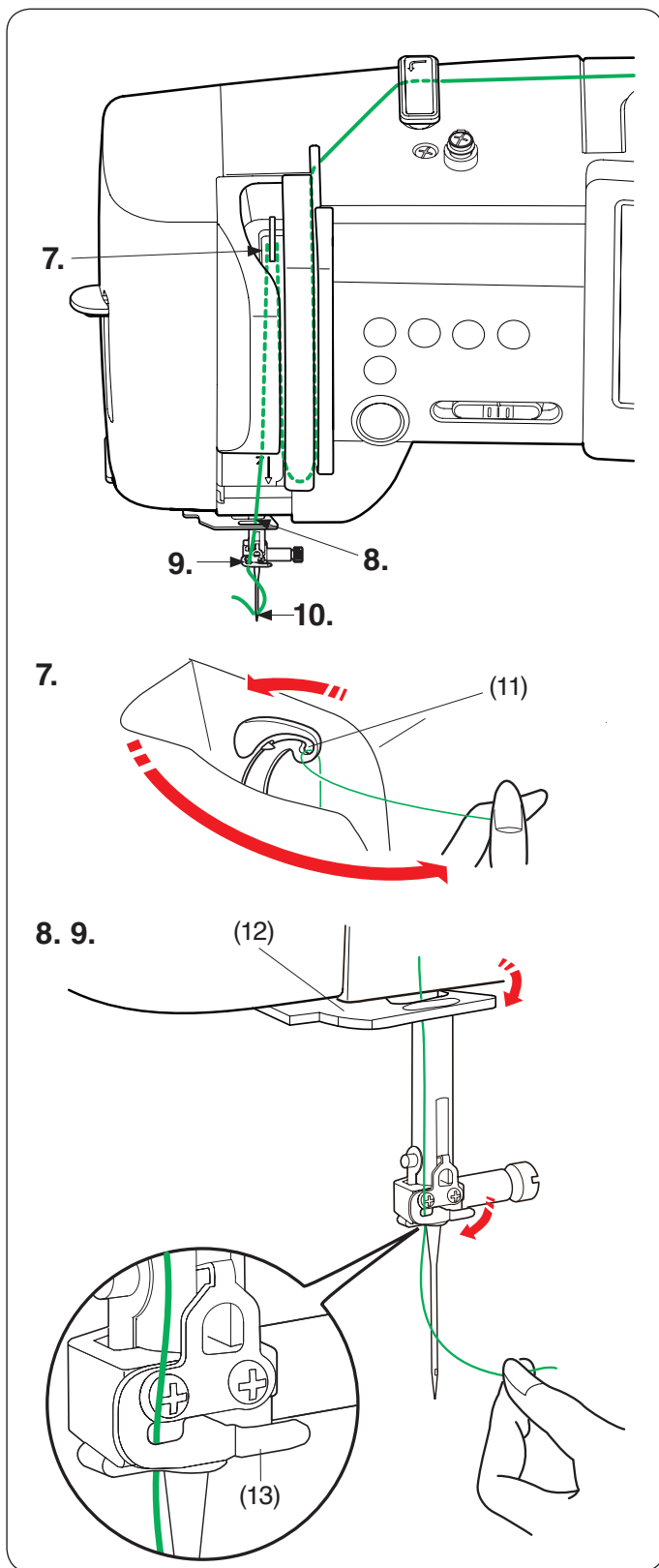

7. While holding the thread at the spool, firmly draw the thread up and to the back of the take-up lever. Draw the thread forward to draw it into the eye of the take-up lever.

(11) Eye of the take-up lever

8. Then pull the thread down along the left channel and through the lower thread guide.

(12) Lower thread guide

9. Slide the thread from the right of the needle bar thread guide to the left.

Be sure to slide the thread to the end of the slit as shown.

(13) Needle bar thread guide

10. Thread the needle with the needle threader (refer to the next page).

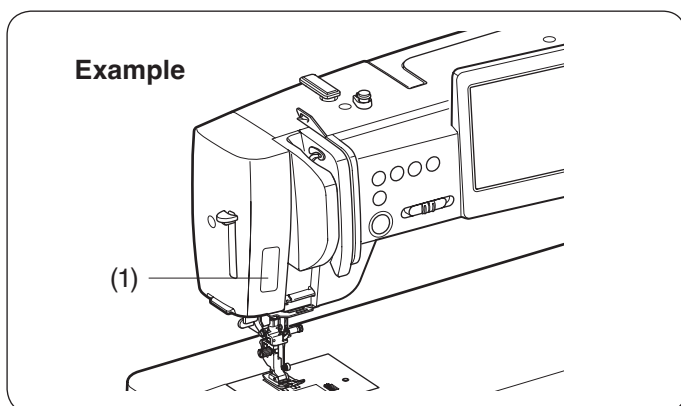

Guide Sticker for Threading

There is a threading guide sticker in the standard accessories. If you wish, you can attach the sticker on the machine to check the threading procedure.

(1) Threading guide sticker

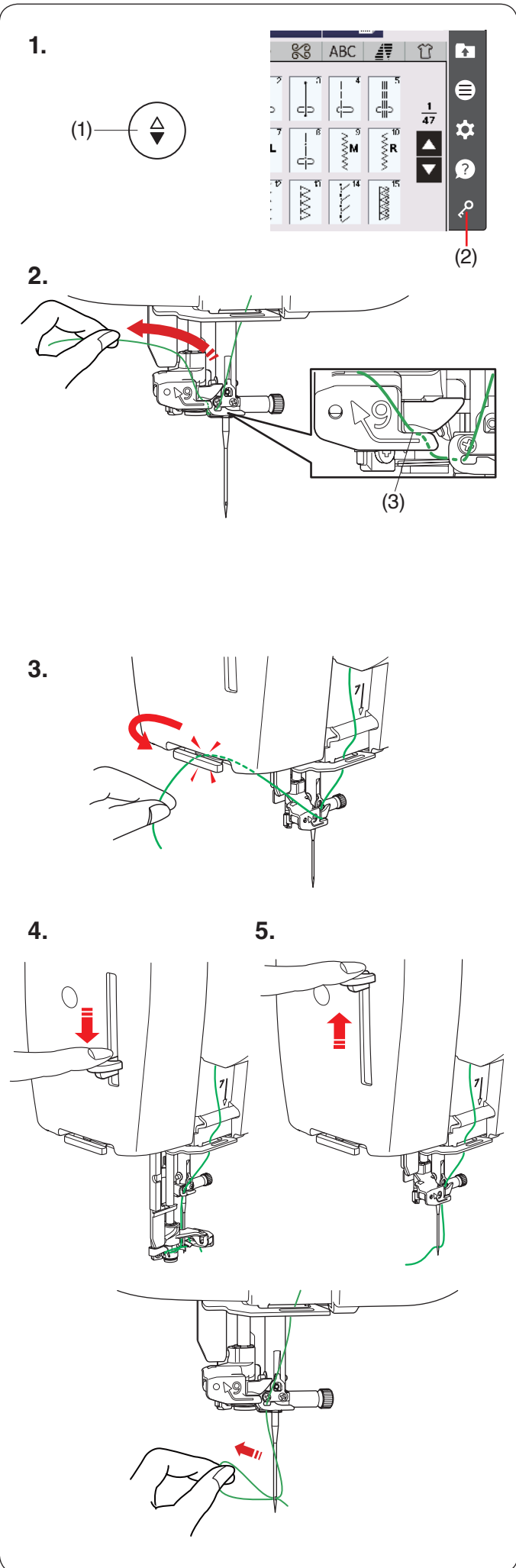

Built-in Needle Threader

NOTE:

- The needle threader can be used with a #11 to #16 needle.
Thread size 50 to 90 is recommended.
Do not use thread size 30 or thicker.
- The needle threader cannot be used with the twin needle.

1. Press the needle up/down button to raise the needle.
Press the lockout key to lock the machine.
 - (1) Needle up/down button
 - (2) Lockout key
2. Pull the thread up to the left while holding the thread near the spool with your hand.

NOTE:

- Be sure that the thread pass the slit of the needle threader as shown.
- (3) Slit

3. Pull the thread up and slip it between the thread cutter and face plate from behind.
Pull the thread toward you to cut.

4. Pull down the needle threader lever as far as it will go.
5. Slowly release the needle threader lever to its original position to pass the thread through the needle eye.

NOTE:

- If the thread loop is formed after releasing the needle threader lever, pull out the thread loop through the needle eye.

Drawing Up the Bobbin Thread

After using auto thread cutting or threading the bobbin holder, you can start sewing without drawing up the bobbin thread.

However, you need to draw up the bobbin thread when sewing gathering stitches etc.

1. Remove the bobbin. Insert the bobbin into the bobbin holder again and rethread the bobbin holder according to the instructions on page 29, but leave a 10 cm (4") tail of bobbin thread as shown.

(1) Bobbin thread

NOTE:

Do not cut the bobbin thread with the thread cutter.

(2) Thread cutter

2. Raise the presser foot. Hold the needle thread lightly with your left hand.

(3) Needle thread

3. Press the needle up/down button twice to lower and raise the needle and pick up the bobbin thread.

(4) Needle up/down button

4. Pull both threads 10 cm (4") under and behind the presser foot.

1.

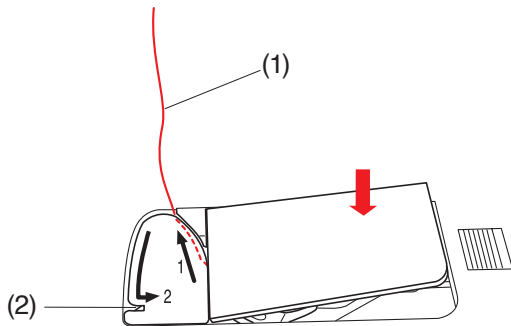

2.

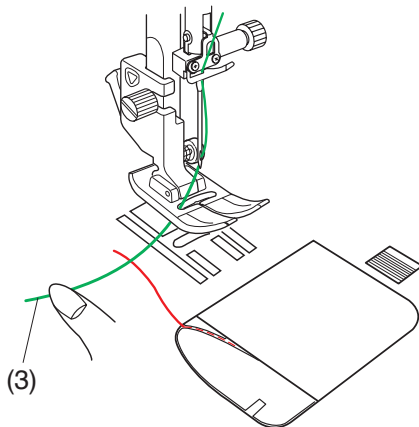

3.

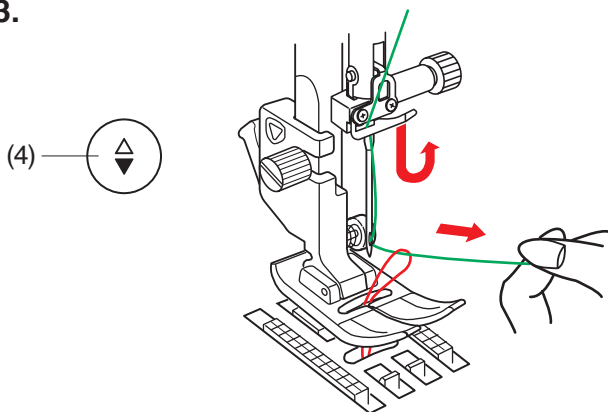

4.

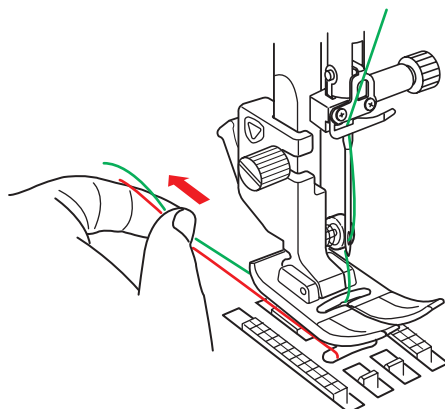

1.

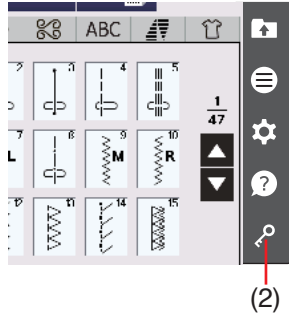

2.



(3)

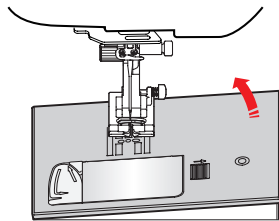

3.

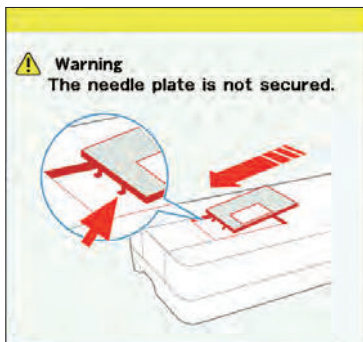

4.

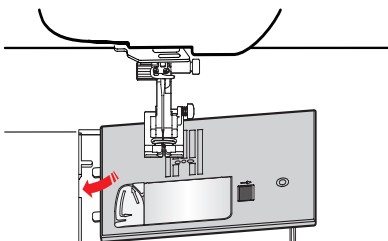

5.

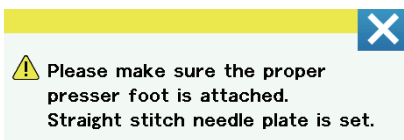

Replacing the Needle Plate

Use the straight stitch needle plate when using the dual feed foot, quilt piecing or free motion.

The straight stitch needle plate can be used for straight stitches with the left, center or right needle drop positions.

Use the professional grade needle plate HP for the straight stitch with the left needle drop position.

Use the professional grade needle plate HP when using the professional grade foot HP.

CAUTION:

- Always make sure to press the lockout key to lockout the machine before replacing the needle plate.
- Never turn the needle plate release dial while running the machine.

NOTE:

When the straight stitch needle plate or the professional grade needle plate HP is attached to the machine, the patterns not suitable for the straight stitch needle plate or the professional grade needle plate HP cannot be selected.

1. Press the needle up/down button to raise the needle. Press the lockout key.

(1) Needle up/down button

(2) Lockout key

2. Press the needle plate release key and the needle plate will automatically snap off.

(3) Needle plate release key

3. A warning message will appear that the needle plate is not secured. Remove the needle plate to the right.

NOTE:

- The needle plate will be returned to the set position automatically after the certain period (needle plate lifter time).
- You can change the needle plate lifter time (refer to page 138).

4. Place the straight stitch needle plate on the machine. Set the left edge of the needle plate into the opening.

5. A message will appear when the straight stitch needle plate is attached. Be sure the proper foot is attached to the machine. Press the X key.

Turn the handwheel slowly and make sure that the needle does not hit the needle plate.

Press the lockout key to unlock the machine.

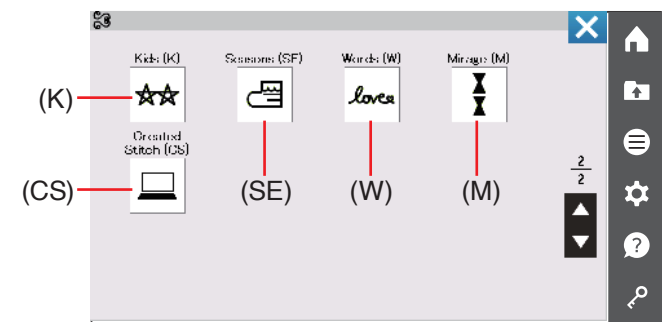
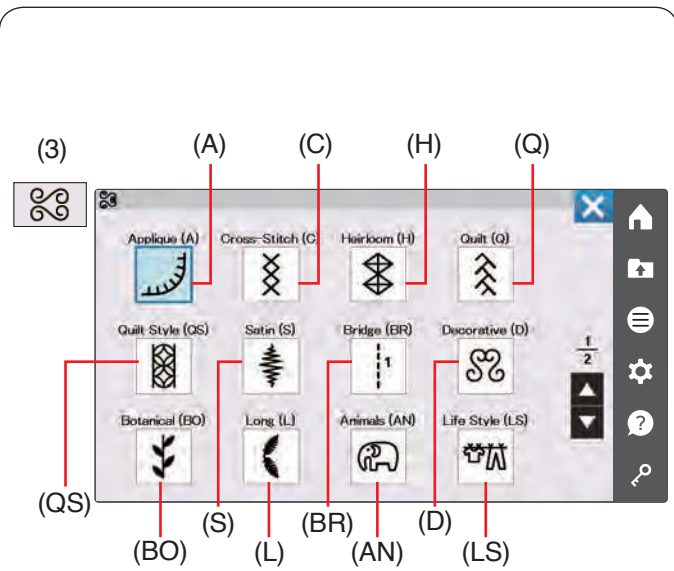

(3) Decorative and quilting stitches

This category consists of the following 17 groups.

- | | |
|---------------------|------------------|
| Applique (A) | Cross-Stitch (C) |
| Heirloom (H) | Quilt (Q) |
| Quilt Style (QS) | Satin (S) |
| Bridge (BR) | Decorative (D) |
| Botanical (BO) | Long (L) |
| Animals (AN) | Life Style (LS) |
| Kids (K) | Seasons (SE) |
| Words (W) | Mirage (M) |
| Created Stitch (CS) | |

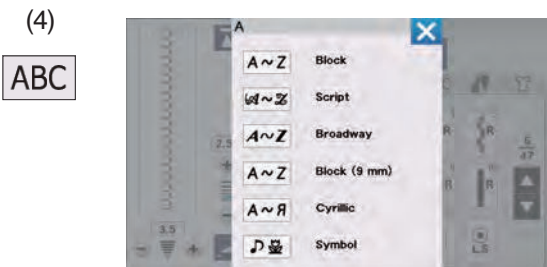

(4) Monogramming

You can program lettering as well as a combination of characters and symbol patterns (refer to pages 97-102).

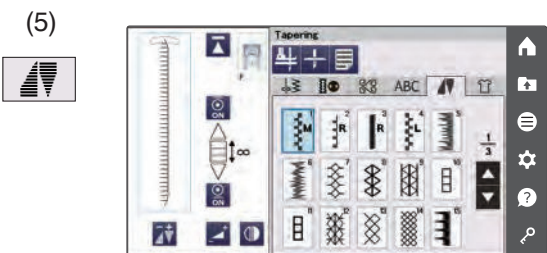

(5) Tapering

You can taper the beginning and end of the decorative stitch patterns to create tapered corners and points (refer to pages 91-96).



(6) Sewing applications

You can select the appropriate stitch for a specific sewing project and fabric type from the designated applications in this category (refer to pages 104-132).

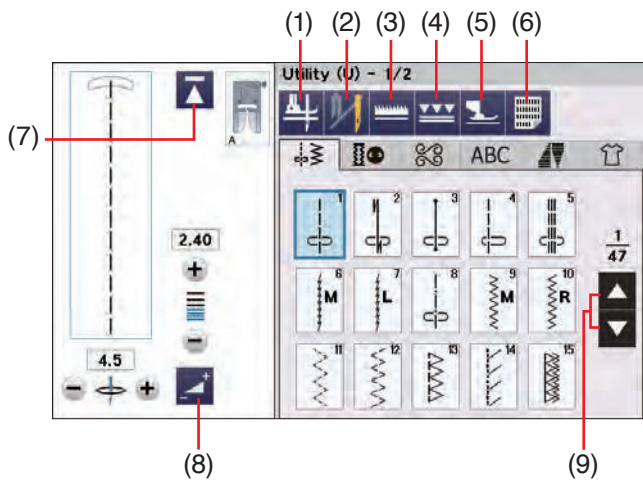

Function Keys

(1) Foot-up key

If this option is turned on, the needle stops at the down position and the presser foot will automatically go up when the machine stops.

Press this key to turn this option on or off (refer to page 50).

(2) Twin needle key

Press this key to set the stitch width for twin needle sewing (refer to pages 85-86).

(3) Drop feed key

This key is available with the utility stitch group and some sewing applications.

Press this key to drop or raise the feed dogs.

(4) Dual feed key

Press this key for dual feed sewing (refer to pages 42-43).

(5) Floating mode key

Press this key for floating mode (refer to page 45).

(6) Stitch reference key

Press the stitch reference key to show the stitch reference chart.

(7) Startover key

If you stop sewing in the middle of a stitch pattern and wish to sew the pattern again from the beginning, press this key before you start sewing.

Press this key once to startover from the beginning of the current pattern, or press this key twice to startover from the beginning of the first pattern of the combination (refer to page 89).

(8) Adjust key

Press this key to expand the manual setting window to show more options (refer to page 48).

(9) Page keys

Press the page key to display the next page or previous page. Press and hold the page key to turn the pages continuously.

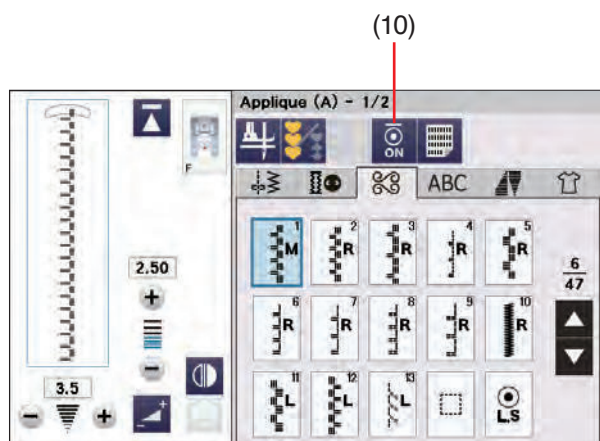

(10) Initial lock stitch key

Press this key to turn on or off the initial lock stitch.

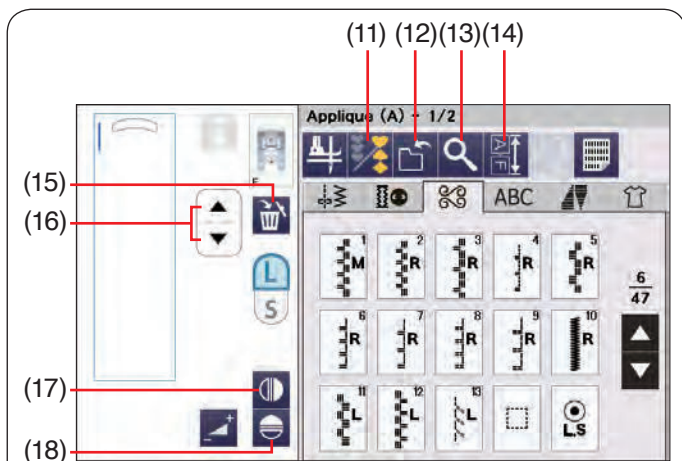

(11) Program key

Press this key to program a pattern combination. When this key is pressed, the save file key, preview key, pattern combination length key, delete key, letter size key and cursor keys will appear (refer to pages 87-96).

(12) Save file key

Press this key to save the pattern combination as a file.

(13) Preview key

Press this key to view the stitch image of the entire pattern combination.

(14) Pattern combination length key

Press this key to check the total length of the pattern combination.

(15) Delete key

Press this key to delete a pattern from the pattern combination.

(16) Cursor keys

Press one of the cursor keys to move the cursor up or down.

(17) Vertical mirror image key

Press this key to sew a vertical mirror image of the selected pattern (refer to page 87).

(18) Horizontal mirror image key

Press this key to sew a horizontal mirror image of the selected pattern. The key is grayed out if the selected pattern cannot be turned over (refer to page 87).

(19) Letter size key

Press this key to select the full size (L) or small size (S).

(20) Letter case key

Press this key to select upper case or lower case for monograms.

(21) Character type key

Press this key to select the character type among alphabets, numerals, symbols and European characters.

(22) Needle stop position key

You can select the needle stop position to be either up or down by pressing the needle stop position key.

(23) Hand stitch style key

Press this key to open the hand stitch style window (refer to page 103).

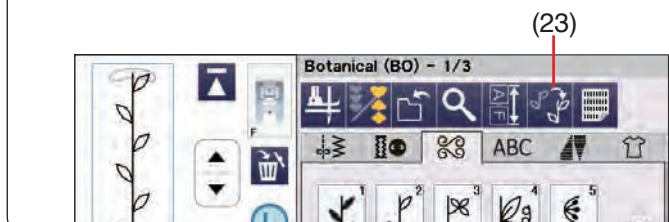
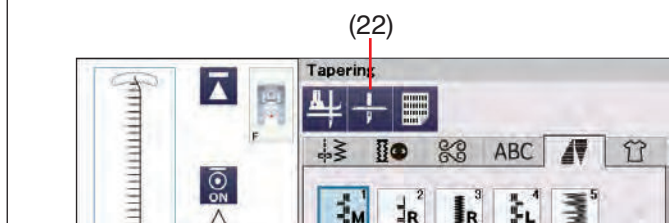
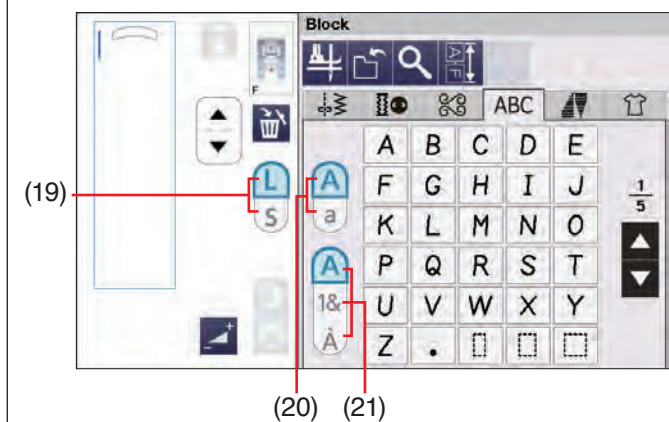

Utility Stitches

Straight Stitches

Patterns U1 to U5 are straight stitches for seaming. Press the pattern selection key for the desired stitch.

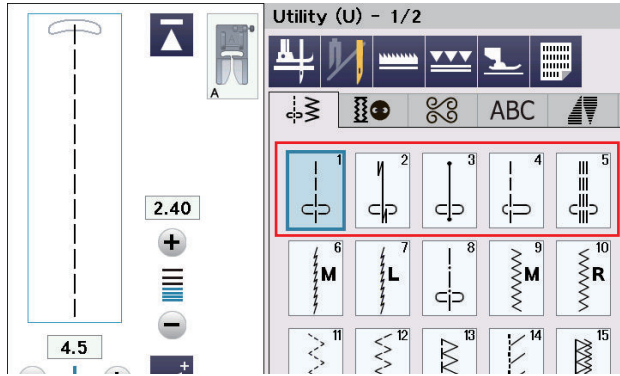

Starting to sew

Place the fabric next to the seam guide line on the needle plate. Lower the needle to the point where you want to start.

Pull the needle thread towards the rear and lower the foot.

NOTE:

Pull the needle thread to the left when using satin stitch foot F, open-toe satin stitch foot F2, dual feed foot or automatic buttonhole foot R.

Press the start/stop button or foot control to start sewing. Gently guide the fabric along the seam guide line letting the fabric go naturally.

(1) Start/stop button

Sewing from the Edge of Thick Fabric

The black button on the zigzag foot A locks the foot in the horizontal position.

This is helpful when you start sewing at the extreme edge of thick fabrics or for sewing across a hem.

Lower the needle into the fabric at the point where you wish to start sewing.

Lower the foot while pushing in the black button. The foot is locked in the horizontal position to avoid slipping.

After a few stitches, the black button is released automatically.

(2) Black button

Changing Sewing Direction

Stop the machine and press the presser foot lifter button to raise the presser foot.

Pivot the fabric around the needle to change the sewing direction as desired.

Start sewing in the new direction.

NOTE:

If you turn on the foot up option, the presser foot will automatically go up when the machine stops (refer to page 50).

Turning a Square Corner

To maintain a 5/8" seam allowance after turning a square corner, use the cornering guide on the needle plate.

Stop sewing when the front edge of fabric reaches the cornering guide lines.

Press the presser foot lifter button and turn the fabric 90 degrees.

Start sewing in the new direction.

(3) Cornering guide

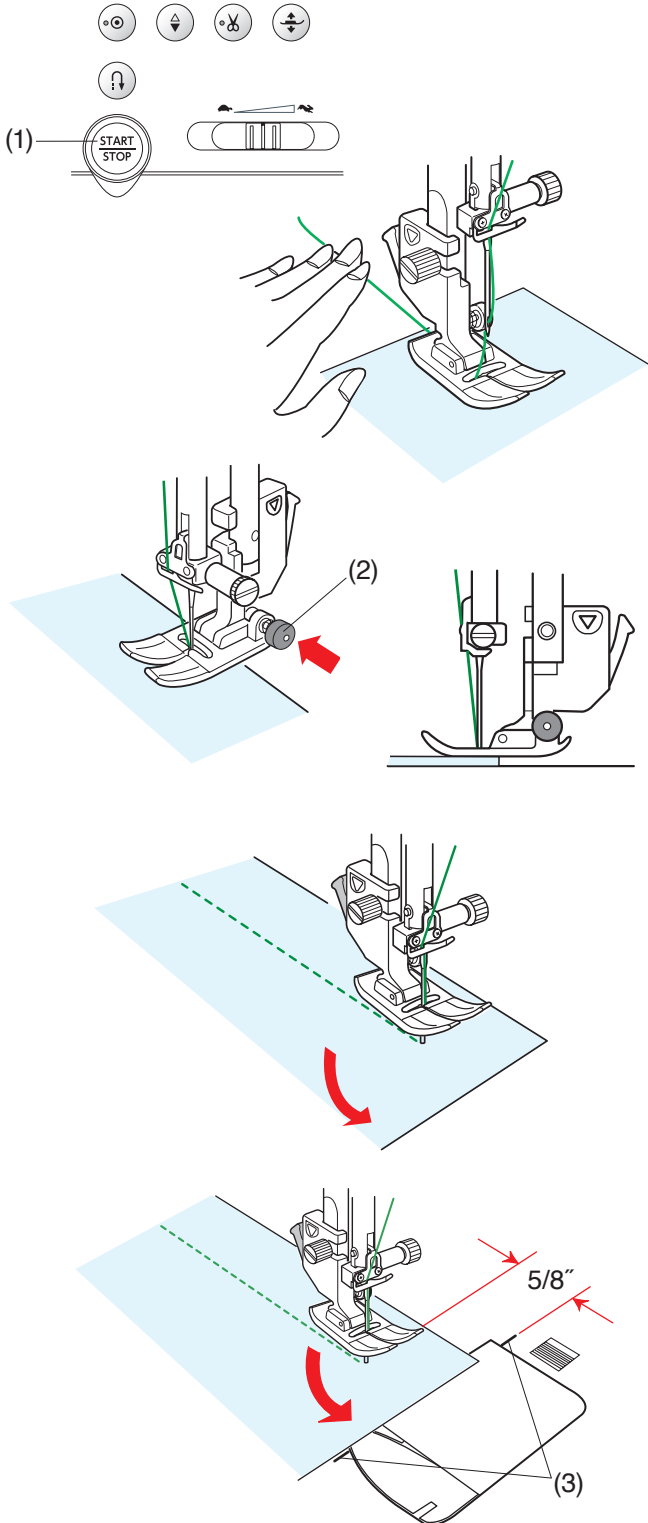

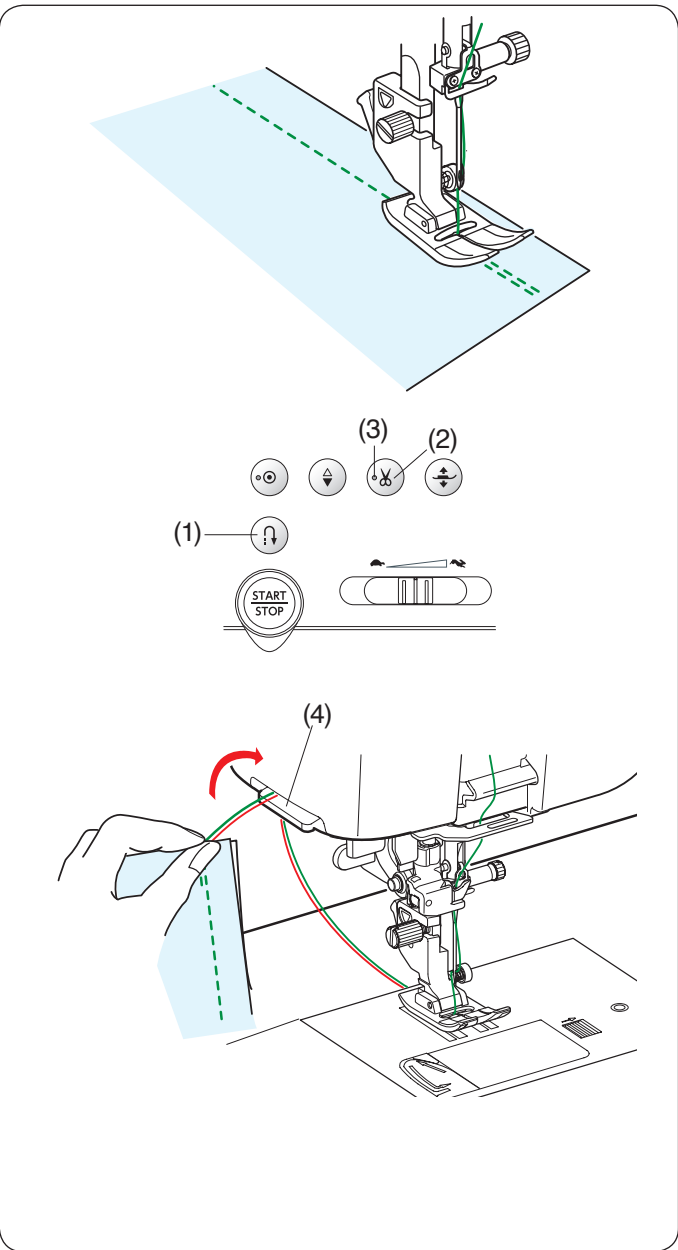

Securing Seams

For fastening the ends of seams, press the reverse button and sew several reverse stitches. The machine sews in reverse as long as you press and hold the reverse button.

- (1) Reverse button

Press the reverse button once when sewing the lock-a-matic stitch (pattern U2) or locking stitch (pattern U3) and the machine will lock the stitches off and stop automatically.

Cutting Threads

To cut the threads after finishing sewing, press the thread cutter button. The needle bar and presser foot will automatically go up after trimming the threads.

- (2) Thread cutter button

NOTE:
 The thread cutter does not function when the LED signal is turned off or the presser foot is raised with the presser foot lifter.
 Use the thread cutter on the face plate to cut specialized, #30 or thicker threads if the auto thread cutter does not work well.
 (3) LED signal

To use the thread cutter on the face plate, remove the fabric and draw it to the back. Pull the threads up and slip them between the thread cutter and face plate from behind. Pull the threads toward you to cut.

- (4) Thread cutter

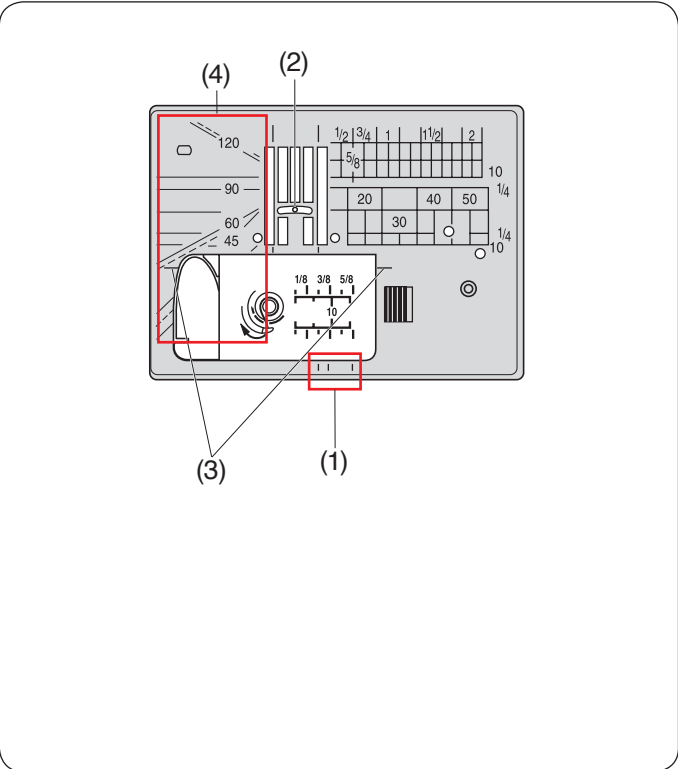

Needle Plate Guides

The seam guides are marked on the needle plate and hook cover plate. The seam guides for 1/4", 3/8" and 5/8" are also marked on the front of the needle plate.

- (1) Seam guides on the front of the needle plate

The numbers on the needle plate indicate the distance from the center needle position in millimeters and inches.

- (2) Center needle position

The cornering guides are very useful when turning a square corner (refer to page 39).

- (3) Cornering guide

The angle scales on the needle plate are useful for patchwork piecing (refer to page 79).

- (4) Angle scales

Variety of Straight Stitches

U1 Straight stitch in center needle position

Use this stitch for seaming, rolled hemming etc.

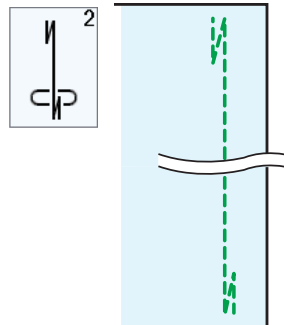
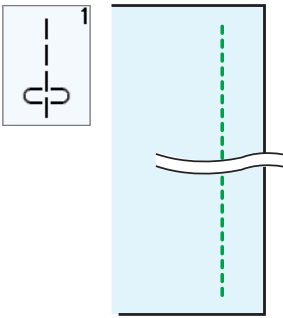

U2 Lock-A-Matic stitch

Use this stitch to secure the beginning and the end of a seam with backstitching.

When you reach the end of the seam, press the reverse button once.

The machine will sew four reverse stitches, four forward stitches, and then stop sewing automatically.

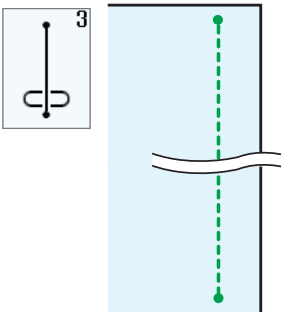

U3 Locking stitch

This unique stitch is used where an invisible locking stitch is needed.

The machine will sew several locking stitches at the beginning and continue sewing forward.

When you press the reverse button at the end of the seam, the machine will sew several locking stitches in place, then stop sewing automatically.

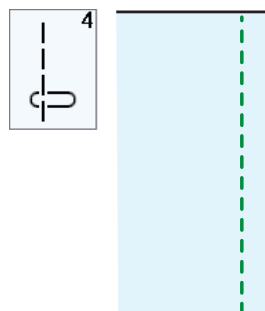

U4 Straight stitch in left needle position

Use this stitch to seam fabrics close to the edge.

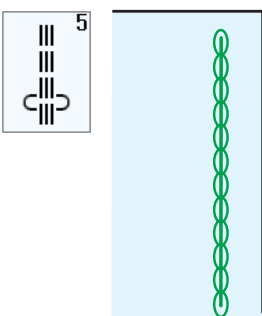

U5 Triple stretch stitch

This strong, durable stitch is recommended for areas where both elasticity and strength are needed to ensure comfort and durability.

Use it to reinforce areas such as crotch and armhole seams.

Also use it when constructing items such as backpacks for extra strength.

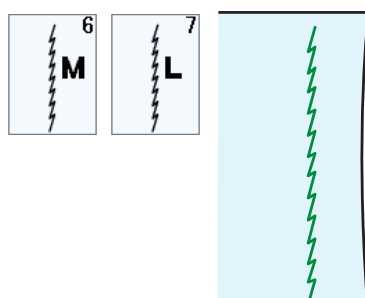

U6, U7 Stretch stitches

These are narrow stretch stitches designed to eliminate puckering on knit fabrics and bias seams, while permitting the seam to be pressed completely open flat.

Use U7 for seaming fine fabrics or stretch fabrics.

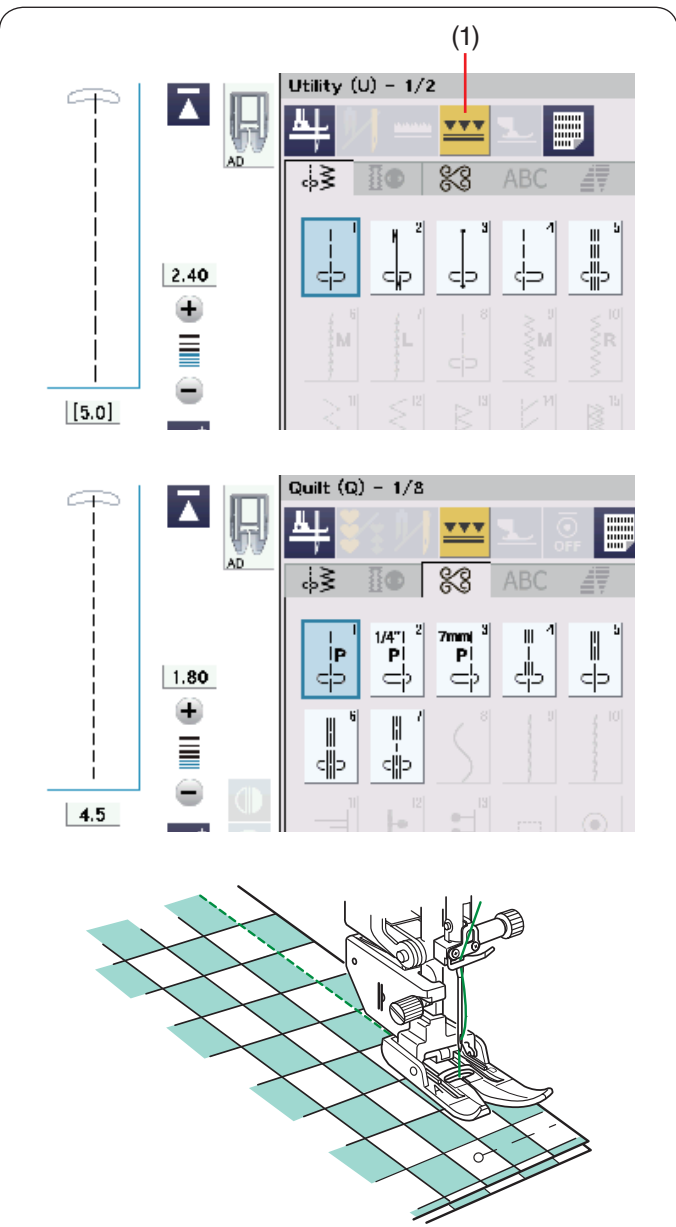

Sewing with the Dual Feed Drive

Patterns U1 to U5 and Q1 to Q7 and some sewing applications can be sewn with the dual feed drive.

The dual feed drive is extremely effective when sewing hard to feed materials such as PVC coated fabric or leather.

It also eliminates layer slippage.

Refer to page 23 for how to attach the dual feed foot and to engage the dual feed drive.

Press the dual feed key and select the desired pattern.

(1) Dual feed key

NOTE:

- The patterns not suitable for dual feed sewing are grayed out.
- The dual feed key will gray out or not be indicated if you selected a pattern not suitable for dual feed sewing.

NOTE:



Dual feed quilting piecing foot 1/4" OD appears on the visual touch screen when patterns Q2 or Q3 is selected. Dual feed quilting piecing foot 1/4" OD is an optional item.

Place the fabric under the foot and lower the needle at the point where you wish to start.

Lower the presser foot.

Start sewing at medium speed.

When seaming plaid fabrics, match the plaids of the upper and lower layers and pin them together.

Remove the pins as you sew.

Adjusting dual feed balance

The dual feed balance value should be set at "5", however you may need to adjust the dual feed balance depending on the type of fabric.

Check the feed balance by test sewing on an extra piece of the fabric you intend to use.

Press the adjust key to expand the manual setting window.

(1) Adjust key

(A): If the lower layer puckers, press the "+" key to adjust it (6-10).

(B): If the upper layer puckers, press the "-" key to adjust it (1-4).

(2) Upper layer

(3) Lower layer

Press the close key to shrink the manual setting window.

(4) Close key

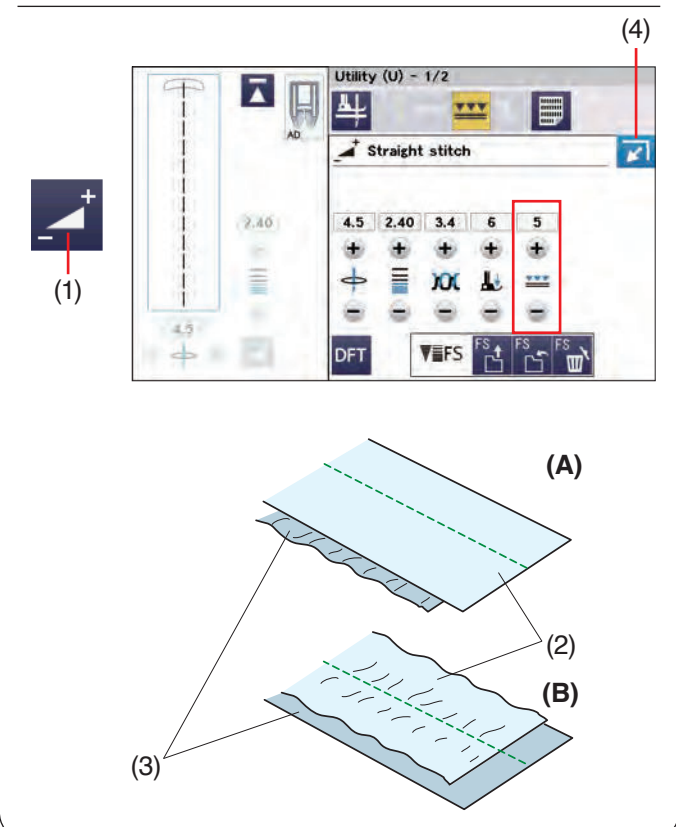

(1)

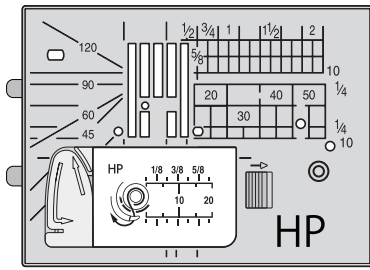

Sewing with the Professional Grade Foot HP

Use the professional grade foot HP for the straight stitch with a professional result.

Replace the needle plate with the professional grade needle plate HP when using professional grade foot HP. Refer to page 34 for how to attach the professional grade needle plate HP.

(1) Professional grade needle plate HP

Refer to page 23 for how to attach the professional grade foot HP.

Attach the professional grade needle plate HP and professional grade foot HP and select the desired pattern.

NOTE:

The patterns not suitable for the professional grade needle plate HP are not displayed.

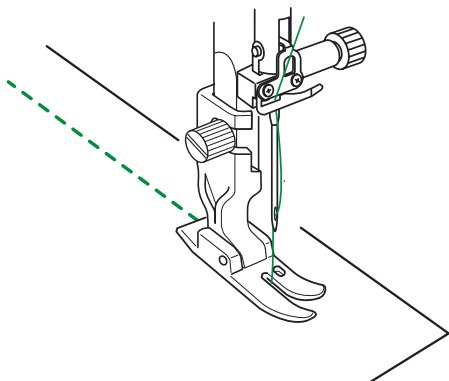
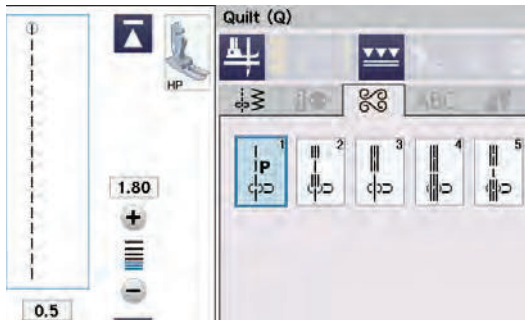
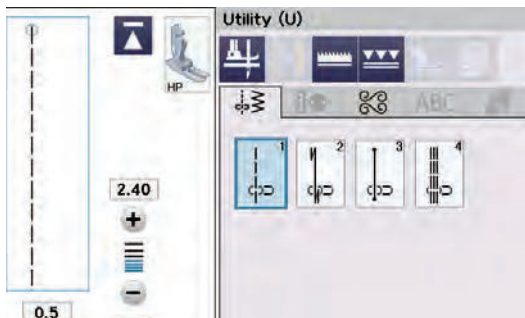

Place the fabric under the foot and lower the needle at the point where you wish to start.

Lower the presser foot.

Start sewing.

1.

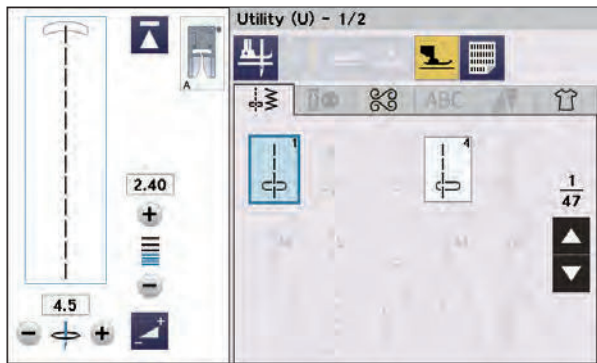
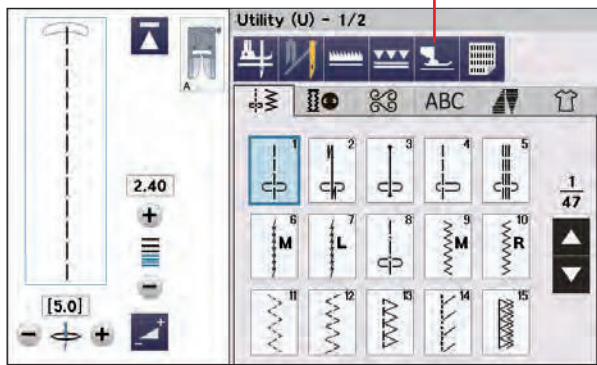

2.

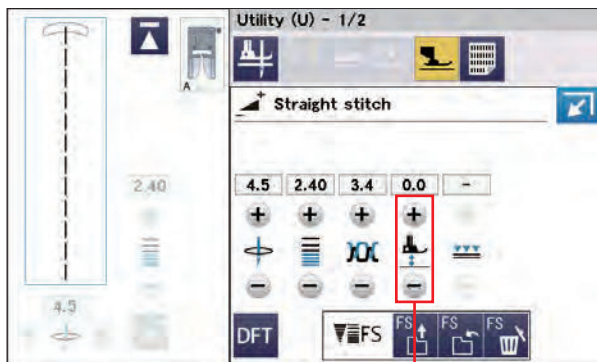

(2)

Floating Mode

You can decrease layer slippage and wrinkles by lifting the presser foot slightly in the floating mode.

1. Press the floating mode key.

(1) Floating mode key

NOTE:

Patterns not suitable for floating mode are grayed out.

2. Press the adjust key to expand the manual setting window. Press the “+” or “-” key to adjust the presser foot height.

(2) Presser foot height adjusting key

Press the “+” key to increase the presser foot height.
Press the “-” key to decrease the presser foot height.

NOTE:

When using the floating mode, always adjust the presser foot height and conduct a test sew on an extra piece of the fabric before the actual sewing.

Using the dual feed foot is recommended to decrease layer slippage when the floating mode does not work.

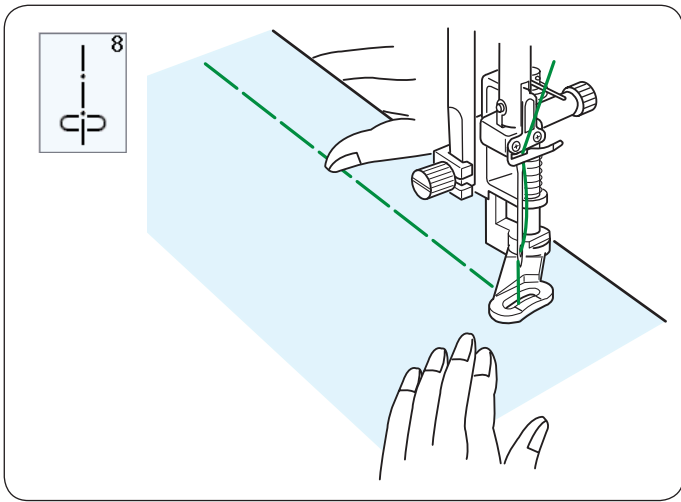

U8 Basting

Refer to page 118 for sewing instructions.

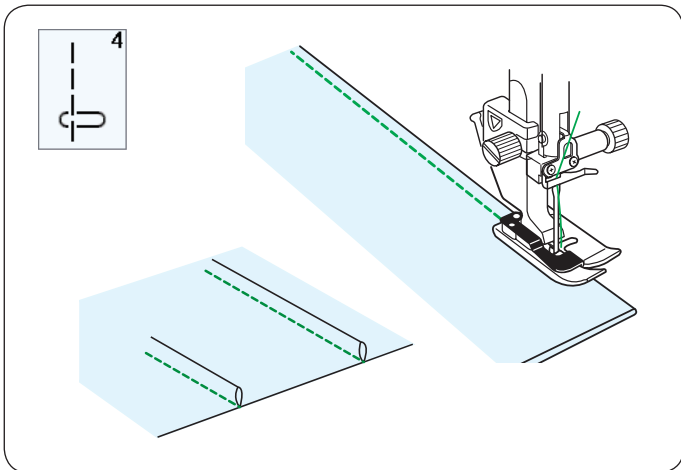

U4 Pintucking

Attach the blind hemming foot G.

Fold the fabric with the wrong sides together.

Place the folded fabric under the blind hem foot.

Align the edge of the fold with the guide on the foot, and lower the foot.

You may adjust the needle drop position to 0.5-1.5 if necessary.

Sew while guiding the edge of the fold along the guide.

Open the fabric and press the tuck to one side.

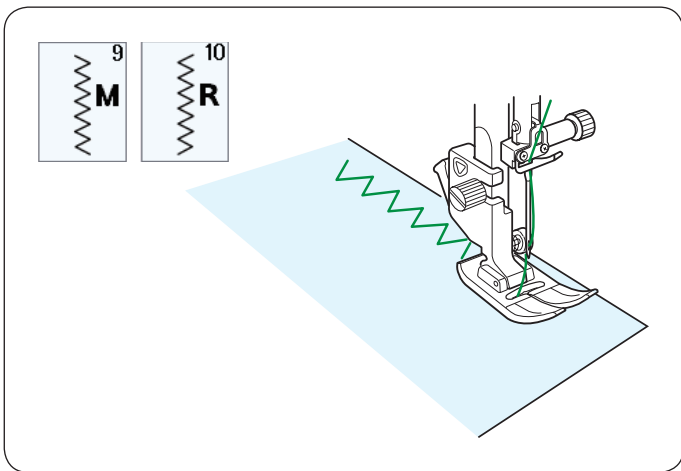

Variety of Zigzag Stitches

U9, U10 Zigzag stitches

Zigzag stitches are used for various sewing needs including overcasting. These stitches can be used on most woven fabrics.

A dense zigzag stitch can also be used for applique.

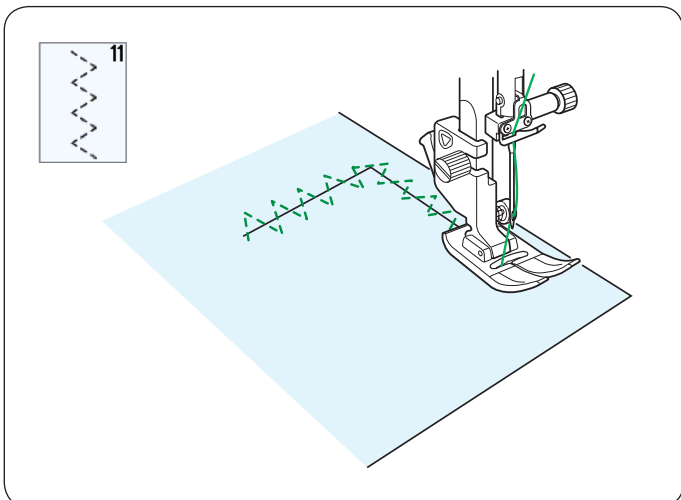

U11 Multiple zigzag stitch

This stitch is used for mending tears.

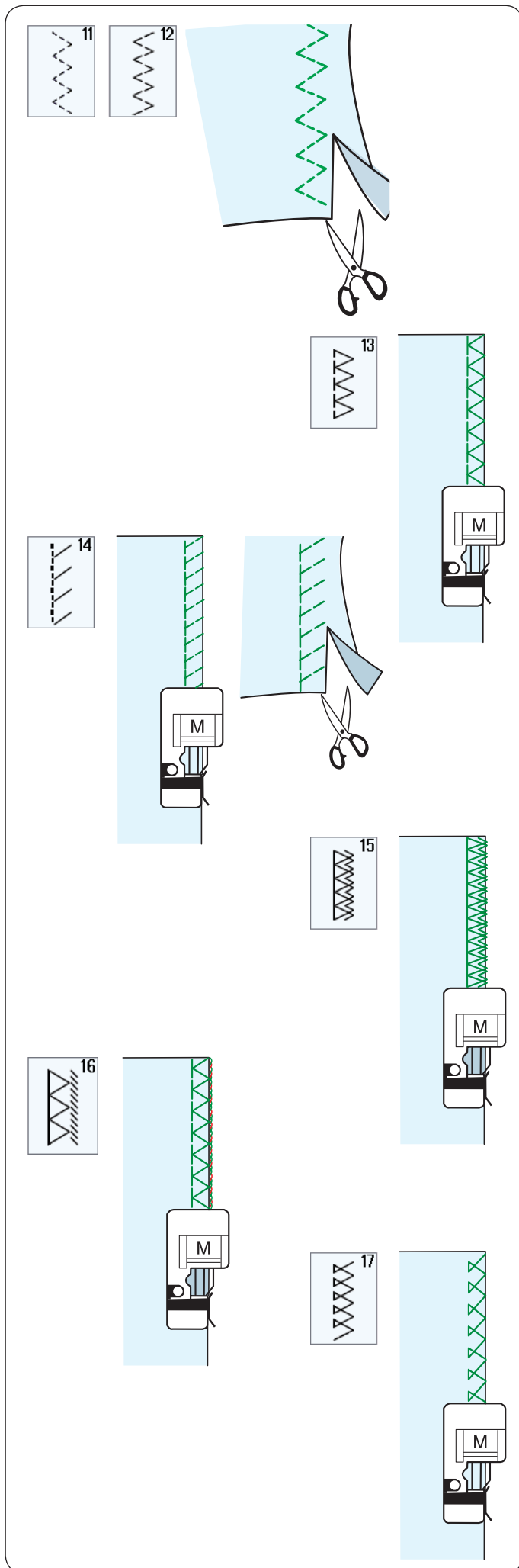

Variety of Overcasting Stitches

U11, U12 Multiple zigzag stitches: Zigzag foot A

These stitches are used to finish a raw edge of synthetics and other stretch fabrics that tend to pucker. Sew along the fabric edge leaving an adequate seam allowance. After sewing, trim the seam allowance close to the stitches.

U13 Overcasting stitch: Overcasting foot M

This stitch can be used to simultaneously seam and overcast edges of fabrics. Use this stitch when you do not need to open seams flat. Place the fabric edge next to the guide of the foot and sew.

U14 Knit stitch: Overcasting foot M

This stitch is recommended for sewing such fabrics as synthetic knits and stretch velour as it provides the greatest amount of elasticity and strength. Place the fabric edge next to the guide of the foot and sew. For better results, use the zigzag foot A and sew leaving an adequate seam allowance. After sewing, trim the seam allowance close to the stitches.

U15 Double overcasting stitch: Overcasting foot M

This stitch is excellent for fabrics that tend to fray extensively such as linens and gabardines. Place the fabric edge next to the guide of the foot and sew. Two rows of zigzag stitches are simultaneously sewn over the edge to insure that the fabric will not ravel.

U16 Overlock stitch: Overcasting foot M

This stitch finishes the edges of fabric in a way similar to a commercial overlocking machine for a professional look. Place the fabric edge next to the guide of the foot and sew.

U17 Overlock stitch: Overcasting foot M

This stitch is used for overcasting knits and stretch fabrics. Place the fabric edge next to the guide of the foot and sew.

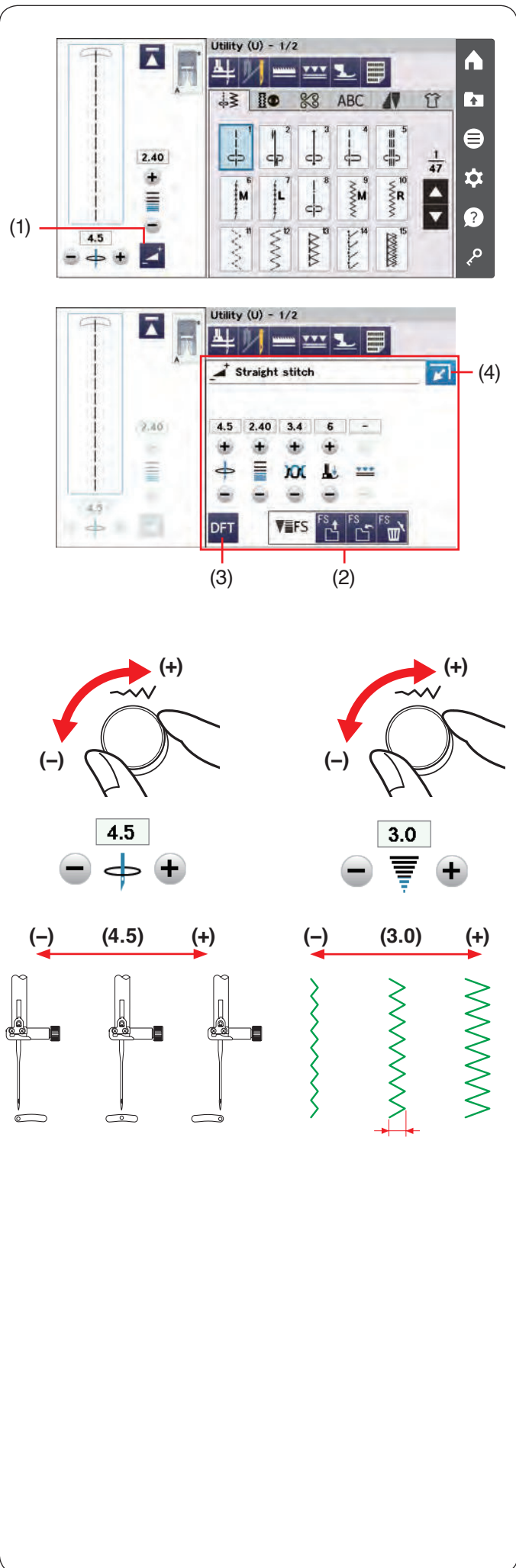

Manual Stitch Settings

You can alter the stitch width (or needle drop position of the straight stitches) and stitch length.

Turn the stitch width or length adjusting dial, or press the “+” or “-” key to change the setting. Press default key to recover the original stitch setting.

When you press the adjust key, the manual setting window expands to show more options.

You can alter other settings such as needle thread tension and presser foot pressure value, depending on the selected stitch pattern.

Press the close key on the right upper corner of the window to shrink the manual setting window.

- (1) Adjust key
- (2) Manual setting window
- (3) Default key
- (4) Close key

Altering needle drop position (straight stitches)

Turn the stitch width adjusting dial clockwise to move the needle drop position to the right.

Turn the stitch width adjusting dial counterclockwise to move the needle drop position to the left.

You can also change the setting with “+” or “-” key.

Press the “+” key to move the needle drop position to the right.

Press the “-” key to move the needle drop position to the left.

Altering stitch width

Turn the stitch width adjusting dial clockwise to increase the stitch width.

Turn the stitch width adjusting dial counterclockwise to decrease the stitch width.

You can also change the setting with “+” or “-” key.

Press the “+” key to increase the stitch width.

Press the “-” key to decrease the stitch width.

NOTE:

The adjustable range of patterns U6-U7, U9-U12 is 0.0 to 7.0.

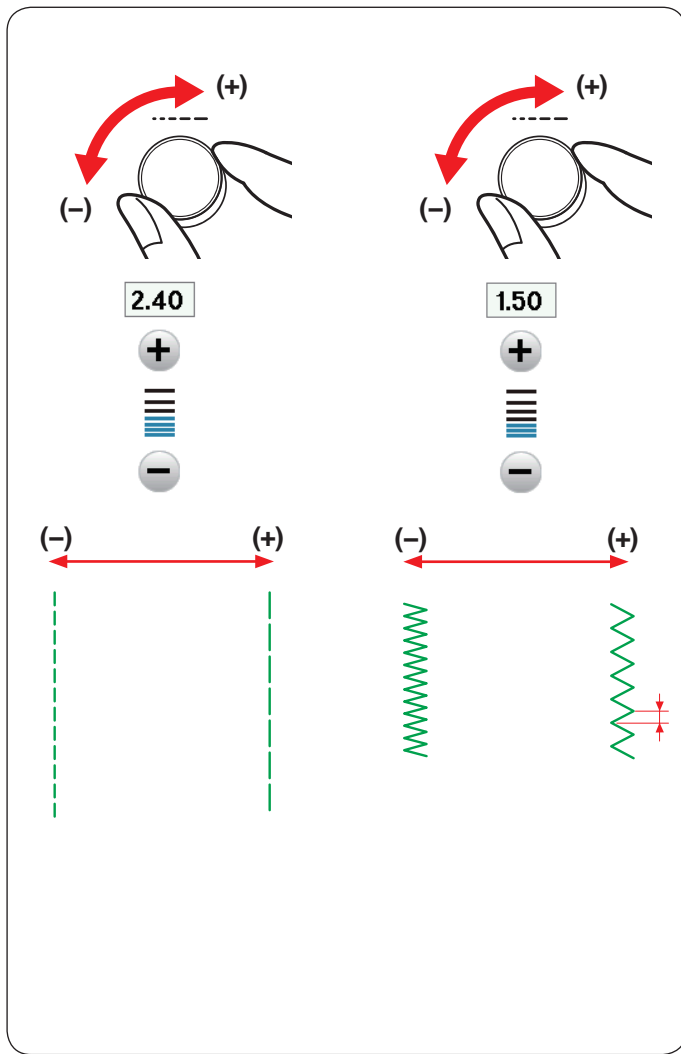

Altering stitch length

Turn the stitch length adjusting dial clockwise to increase the stitch length.

Turn the stitch length adjusting dial counterclockwise to decrease the stitch length.

You can also change the setting with “+” or “-” key. Press the “+” key to increase the stitch length. Press the “-” key to decrease the stitch length.

NOTE:

The adjustable range of patterns U1-U6 and U9-U12 is 0.0 to 5.0, U7 is 1.0 to 5.0.

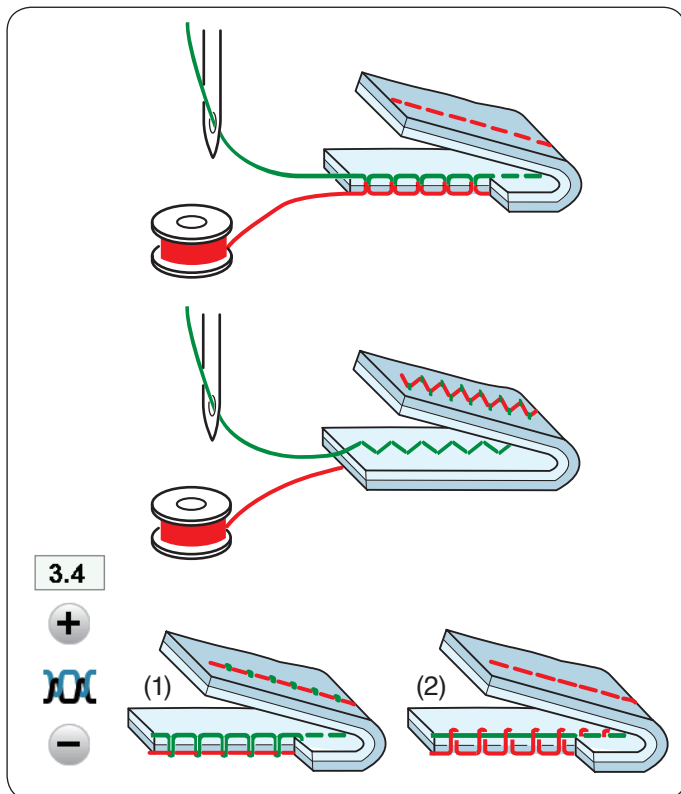

Adjusting Thread Tension

This machine is equipped with automatic thread tension control, which optimizes the tension balance for the selected stitch pattern.

Balanced thread tension

Straight stitch: Both needle and bobbin threads interlock between the layers.

Zigzag stitch: The needle thread appears slightly on the wrong side of the fabric.

However you may need to manually adjust the tension balance depending on the sewing conditions, or you can fine-tune the thread tension to suit your preference.

- (1) Press the “+” key if the tension is too loose.
- (2) Press the “-” key if the tension is too tight.

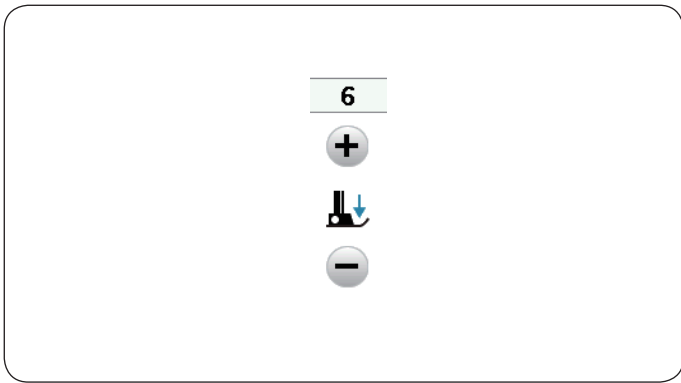

Adjusting Foot Pressure Control

The presser foot pressure is automatically optimized for each stitch pattern.

However, you can adjust the foot pressure manually by pressing the “+” key or “-” key to suit your specific sewing needs.

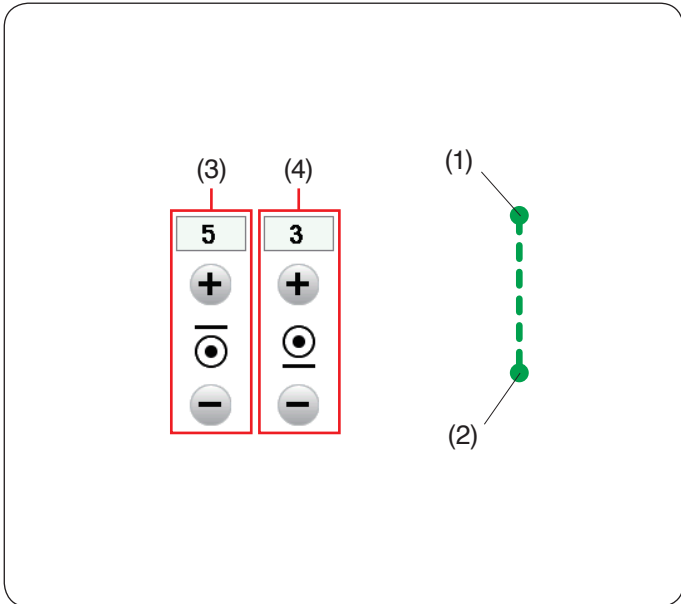

Number of Locking Stitches

The machine sews 5 lock stitches at the beginning and 3 lock stitches at the end.

However, you can change the number of lock stitches at the beginning and the end with this option.

To change the number of lock stitches at the beginning, press the “+” or “-” key in section (3).

To change the number of lock stitches at the end, press the “+” or “-” key in section (4).

- (1) Lock stitches at the beginning
- (2) Lock stitches at the end

NOTE:

This option is available for the locking stitch (U3).

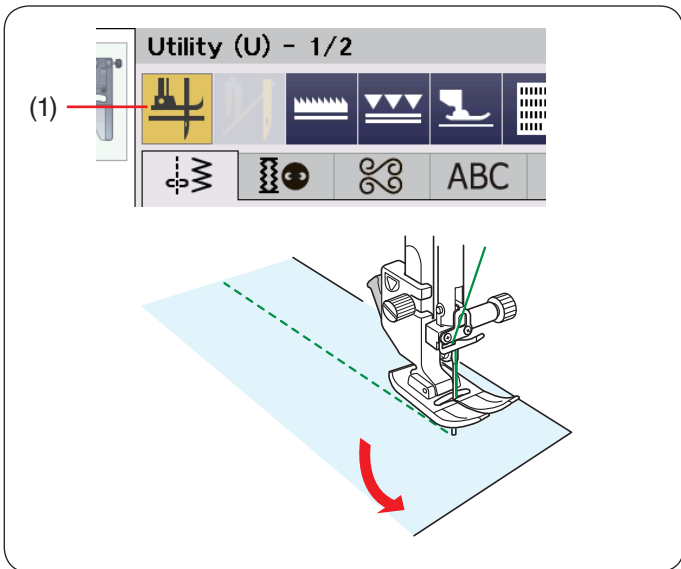

Foot Up for Pivoting

If this option is turned on, the presser foot will automatically go up when the machine stops.

This feature is very useful when turning corners.

Press the foot-up key to turn this option on or off.

- (1) Foot-up key

NOTE:

Height of the foot can be adjusted in the ordinary sewing setting mode (refer to page 140).

Favorite Stitch Adjustment

You can save customized stitch settings (stitch length, stitch width, thread tension and presser foot pressure, depending on the selected stitch patterns) as Favorite Stitch Adjustment. When the favorite stitch adjustment option is turned ON (refer to page 141), the last-used customized stitch settings are automatically assigned when the stitch pattern is selected.

(1) Favorite Stitch Adjustment

NOTE:

- Favorite stitch option cannot be assigned for created stitch (CS).
- Favorite stitch option cannot be used in monogram mode.

Example: To change the preset value of the needle drop position from “4.5” to “5.0”.

Turn the Favorite Stitch Adjustment option ON (refer to page 141).

Select stitch pattern U1.

Press the adjust key. The manual setting window expands to show more options.

The favorite stitch setting option appears on the manual setting window.

Change the needle drop position from “4.5” to “5.0” by turning the stitch width adjusting dial or pressing “+” key. Press the save favorite key.

(2) Favorite stitch setting option

(3) Save favorite key

Save fav. setting dialog box will open.

You can store 2 sets of favorite stitch settings (FS1 and FS2).

Press FS1 or FS2 to register the favorite stitch settings.

(4) FS1

(5) FS2

The square bracket indicates that the customized preset stitch value is applied to the setting.

(6) Square bracket

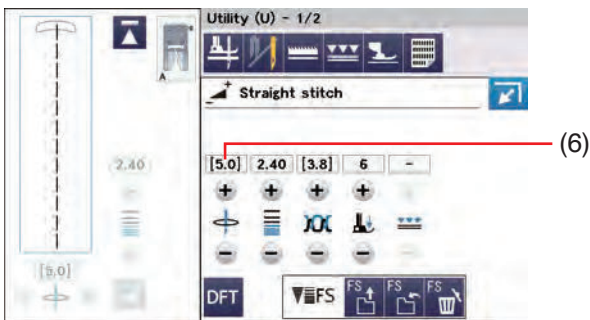
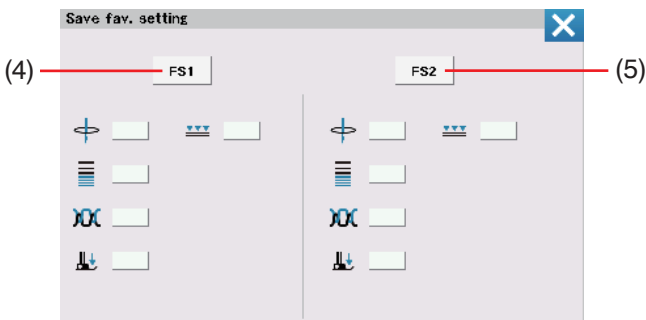
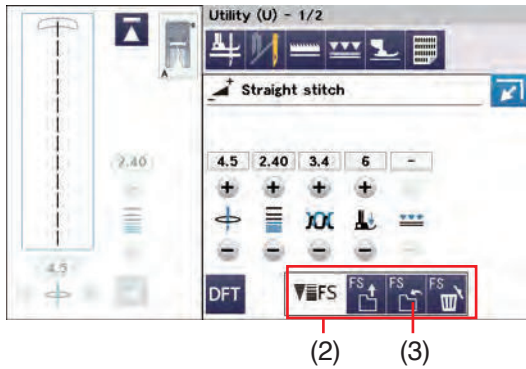
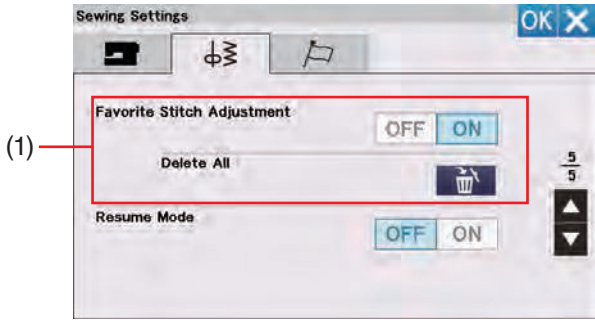

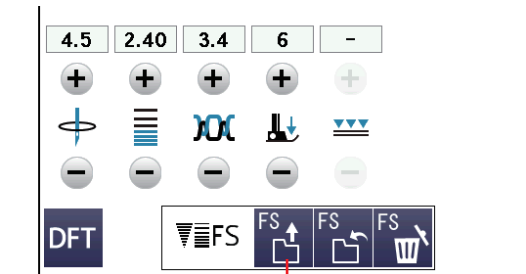

(7)

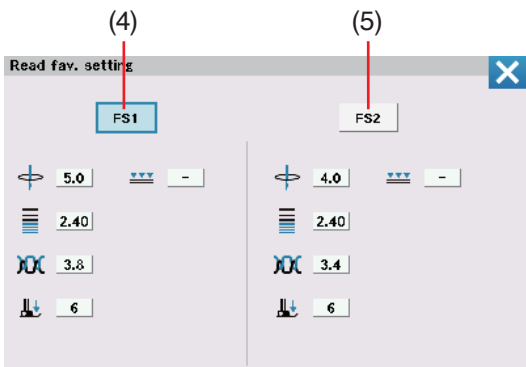

(4)

(5)

To select the favorite stitch settings, press the open favorite key.

(7) Open favorite key

The selected set of favorite stitch settings is indicated in blue.

Select the desired set of customized stitch settings by pressing FS1 or FS2.

(4) FS1

(5) FS2

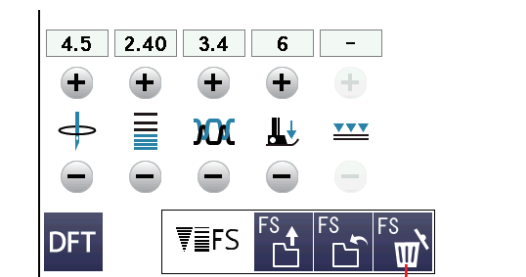

(8)

To delete favorite stitch settings, press the delete key.

Select the desired set of favorite stitch settings by pressing FS1 or FS2.

(4) FS1

(5) FS2

(8) Delete key

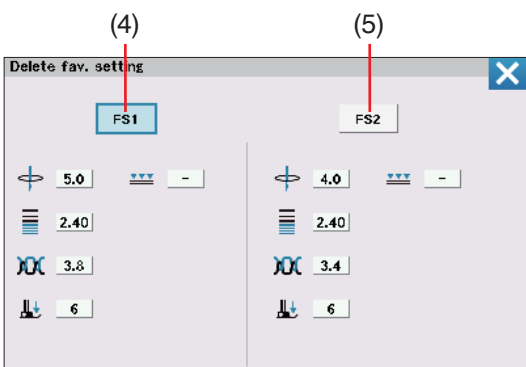

(4)

(5)

Cloth Guide

1.

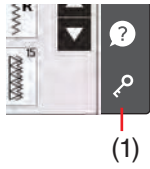

1. Press the lockout key.

(1) Lockout key

Remove the hook cover plate (refer to page 26).

2.

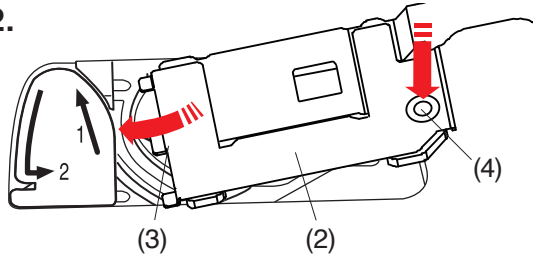

2. Set the left edge of the cloth guide hook cover into the opening. Push down the mark on the cloth guide hook cover to fit in place.

(2) Cloth guide hook cover

(3) Left edge

(4) Mark

3.

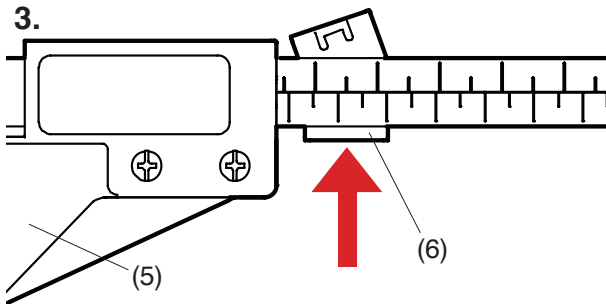

3. Push the lever away from you to release the guide plate.

(5) Guide plate

(6) Lever

4.

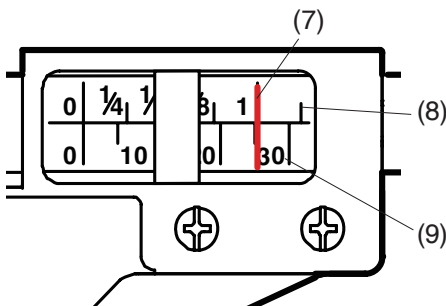

4. Slide the guide plate to your desired position on the scale.

The figure under the red mark indicates distance between the cloth guide to the center needle position in millimeters and inches.

(7) Red mark

(8) Inches

(9) Millimeters

5. 6.

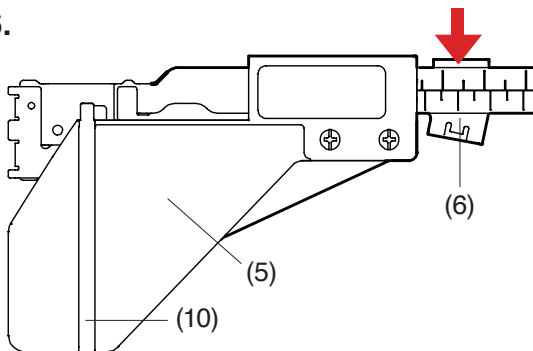

5. Push the lever toward you to secure the cloth guide.

(5) Guide plate

(6) Lever

6. Sew the fabric across the guide.

(10) Guide

7.

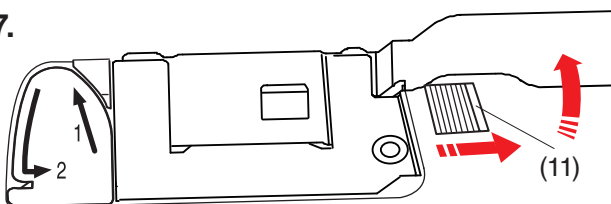

7. To remove the cloth guide hook cover, raise the cloth guide while sliding the hook cover release button to the right. When you cannot see the hook cover release button, slide the guide plate to the right.

(11) Hook cover release button

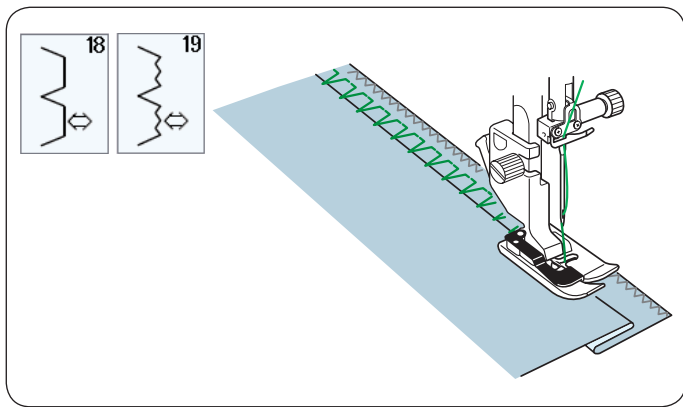

Other Utility Stitches

U18, U19 Blind hemming

Refer to pages 108-109 for sewing instructions.

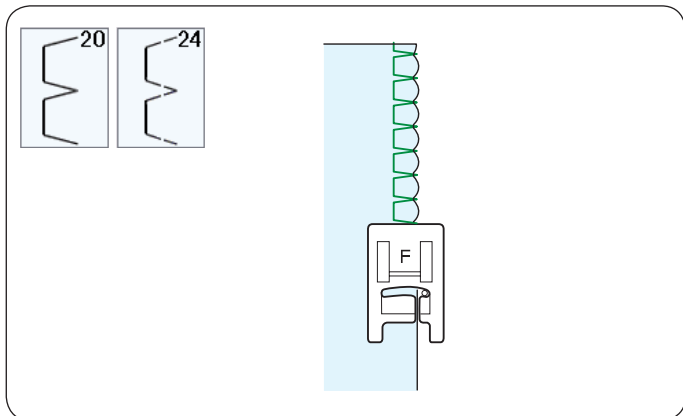

U20, U24 Shell tuck

Refer to page 110 for sewing instructions.

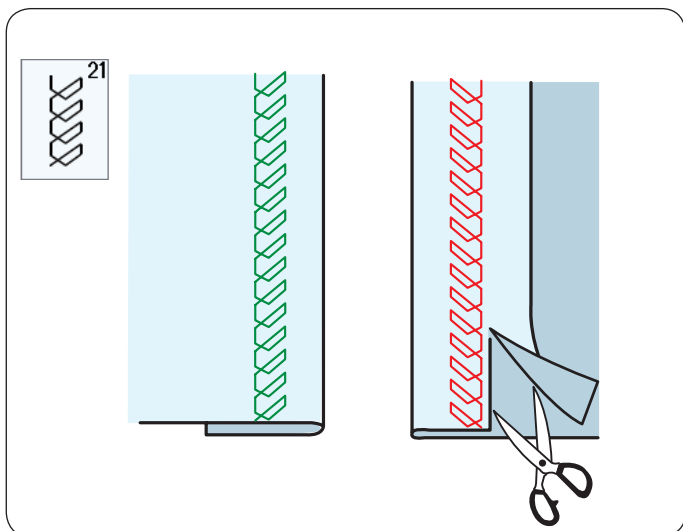

U21 Visible hemming

Fold and press a single hem. Place the fabric with the right side up.

Sew along the fold at the desired depth.

Trim the excess on the wrong side.

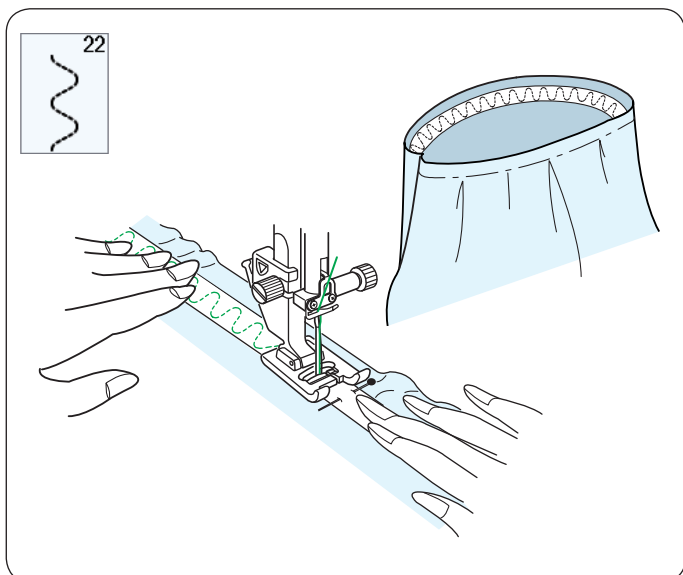

U22 Attaching elastic

Mark the elastic into quarters. Match those to the center front, center back and side seams, and pin the elastic to the fabric.

Place the elastic under the foot and stitch into place while stretching the elastic evenly.

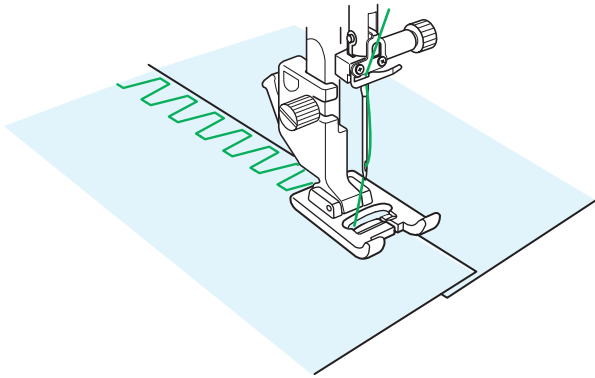
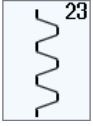

U23 Box stitching

Use this stitch to join heavy weight fabrics. Overlap two raw edges together and use this stitch to join them.
Use also for fagoting.

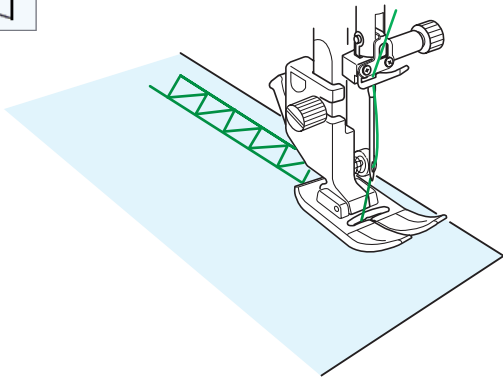
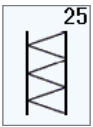

U25 Hemstitch

Use this stitch for fagoting or decorative stitch.

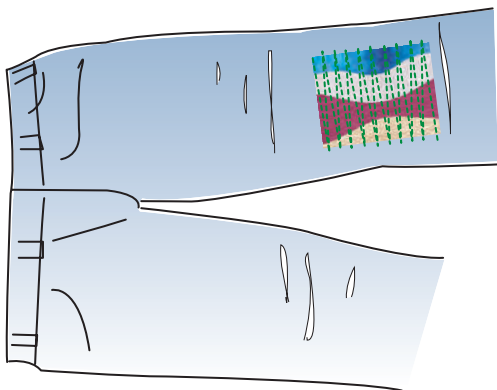
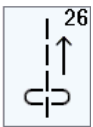

U26 Backward stitch

U26 is backward stitch.
Use this stitch if it is hard to guide the fabric while pressing the reverse button.
The machine sews in reverse without pressing the reverse button so that you can guide the fabric with both hands.

BUTTONHOLES AND SPECIALTY STITCHES

Variety of Buttonholes

B1 Sensor (square) buttonhole

This square buttonhole is widely used on medium to heavy weight fabrics. The buttonhole size is automatically determined by placing a button in the foot.

B2 Automatic (square) buttonhole

This is also a square buttonhole similar to the sensor square buttonhole, but you can manually set the buttonhole size and the machine memorizes it to sew buttonholes of the same size.

B3 Round end buttonhole

This buttonhole is used on fine to medium weight fabrics especially for blouses and children's clothes.

B4 Fine fabric buttonhole

This buttonhole is rounded at both ends and is used on fine, delicate fabrics such as fine silk.

B5 Keyhole buttonhole

The keyhole buttonhole is widely used on medium to heavy weight fabrics. It is also suitable for larger and thicker buttons.

B6 Rounded keyhole buttonhole

This buttonhole is used for thicker buttons on medium weight fabrics.

B7 Tailored buttonhole

This durable buttonhole is used with thick buttons and heavy fabrics.

B8 Keyhole buttonhole (tapered reinforced end)

This buttonhole is used for tailored clothing, woven cloth etc.

B9 Keyhole buttonhole (heavy reinforced end)

This buttonhole is used for tailored clothing, jackets, particularly men's wear, woven cloth etc.

B10 Stretch buttonhole

This buttonhole is suitable for stretch fabrics. It can also be used as a decorative buttonhole.

B11 Knit buttonhole

This buttonhole is suitable for knit fabrics. It can also be used as a decorative buttonhole.

B12 Antique buttonhole

This buttonhole looks like the heirloom stitch. It has an attractive handmade appearance and makes a nice decorative buttonhole.

B13 Weltd buttonhole

This is a template pattern for the hand sewn welted (bound) buttonhole.

NOTE:

B3-B13 are sensor buttonholes and the sewing procedure is the same as for B1.

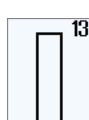
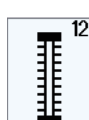
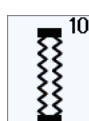
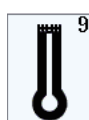
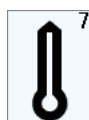
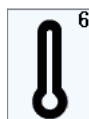

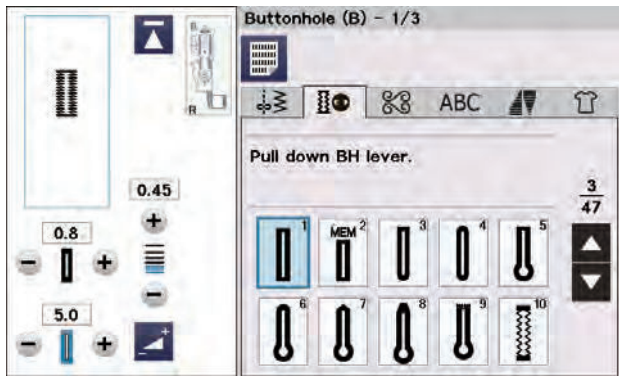

B1 Sensor (Square) Buttonhole

The size of a buttonhole is automatically set by placing a button in the rear of automatic buttonhole foot R. The button holder of the foot takes a button size of 1 cm (3/8") to 2.5 cm (1") in diameter. When selecting the buttonholes, the visual touch screen advises you to lower the buttonhole lever.

NOTE:

- It is sometimes necessary to change buttonhole size to match certain heavy or specific fabrics and threads.
- Make a test buttonhole on an extra piece of the fabric to check your settings.
- The preset width of the buttonhole is suited for ordinary buttons.
- Apply an interfacing to stretch or fine fabrics.

Sewing

1. Pull the button holder to the back, and place the button in it. Push it together tightly on the button.
 - (1) Button holder

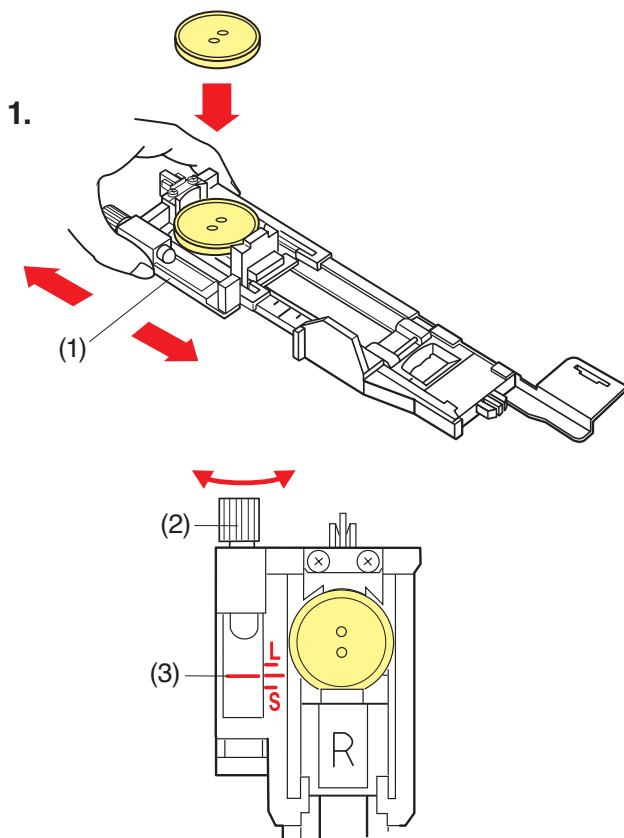

NOTE:

- Check the length of the test buttonhole, and adjust the buttonhole length if necessary by turning the adjusting screw on the buttonhole foot.
 - To increase the buttonhole length, turn the adjusting screw to move the marker toward "L".
 - To decrease the buttonhole length, turn the adjusting screw to move the marker toward "S".
- (2) Adjusting screw
 - (3) Marker

2.

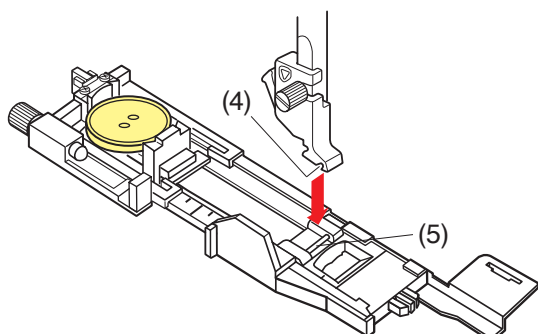

2. Press the needle up/down button to raise the needle. Press the lockout key. Raise the presser foot and attach the automatic buttonhole foot R snapping the pin into the groove of the foot holder. You may lift the presser foot lifter to the extra lifted position when placing the automatic buttonhole foot under the foot holder. Press the lockout key to unlock the machine.
 - (4) Groove
 - (5) Pin

3.

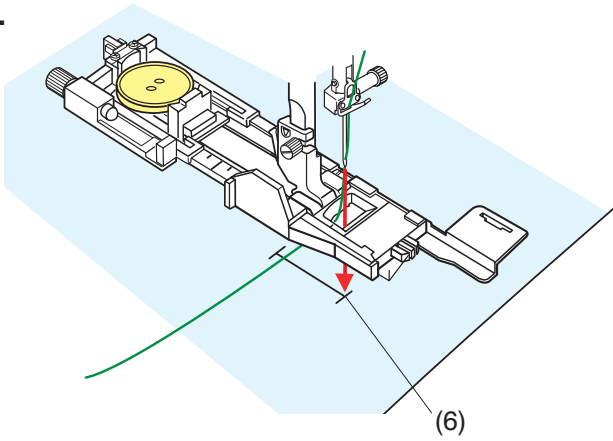

3. Draw the needle thread to the left through the hole of the foot.

Mark the buttonhole position on the fabric and place it under the buttonhole foot. Lower the needle at the starting point by turning the handwheel.

(6) Starting point

4.

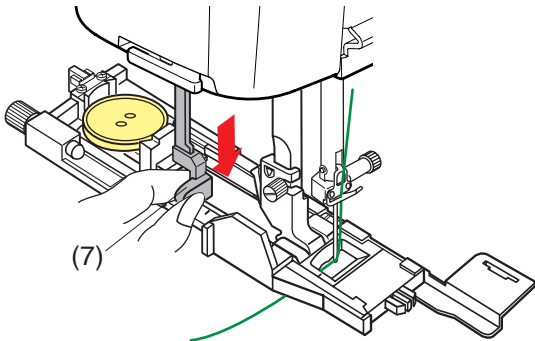

4. Lower the presser foot and pull the buttonhole lever down as far as it will go.

(7) Buttonhole lever

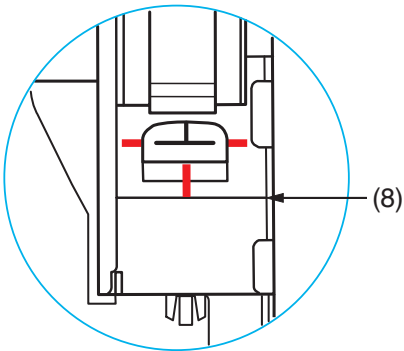

NOTE:

Make sure there is no gap between the slider and front stopper, otherwise the buttonhole will be out of position or there will be a sewing gap.

(8) No gap

(9) Starting point

(10) Sewing gap

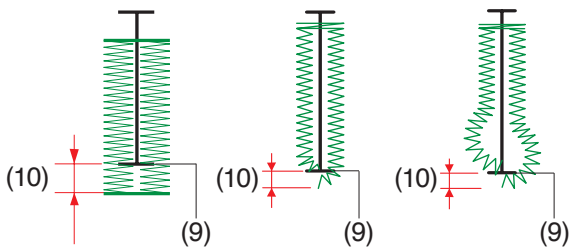

5.

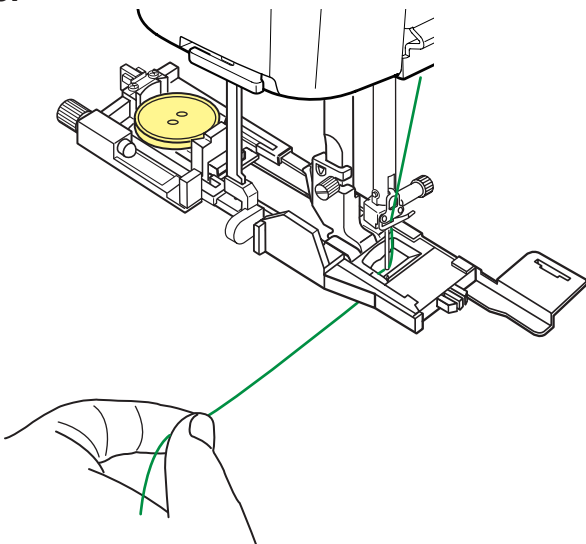

5. Start sewing while pulling the needle thread lightly to the left. After sewing a few stitches, free the thread and continue sewing.

NOTE:

If you start sewing without pulling down the buttonhole lever, the visual touch screen will show a warning and the machine will stop after a few stitches. Pull the buttonhole lever down and start sewing.

6.

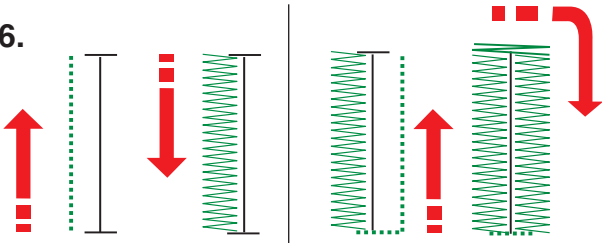

6. The buttonhole is sewn automatically in the sequence shown. When the buttonhole is finished, the machine will stop automatically with the needle in the up position. Press the thread cutter button and remove the fabric.

7.

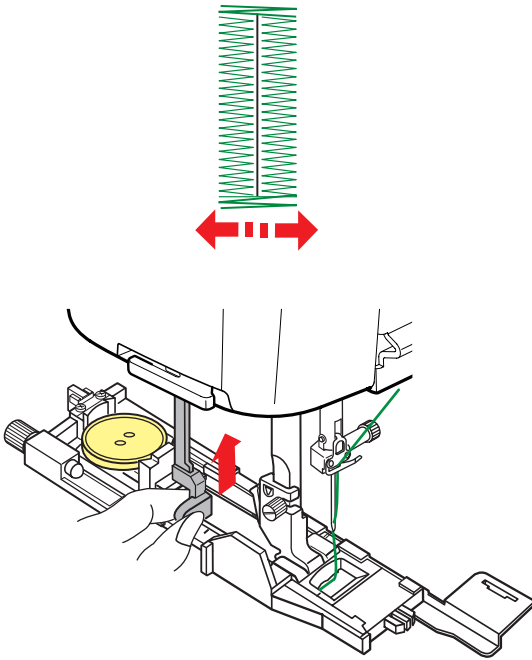

7. After you finish buttonhole sewing, push the buttonhole lever up as far as it will go.

8.

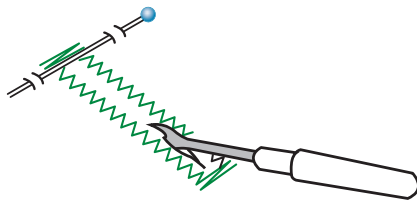

8. Place a pin just below the bartack at each end to prevent accidentally cutting the threads. Cut the opening with the seam ripper.
Use a punch to open a keyhole buttonhole.

NOTE:

A punch is not included with this machine.

Completed.
Raise presser foot.

Double Layer Buttonhole

To make a sturdy buttonhole, sew another layer of buttonhole stitches over the previous stitches. After the buttonhole is finished, simply start the machine again.
Do not raise the foot or buttonhole lever.
Do not reselect the pattern.

NOTE:

This function is disabled if Thread Cut after Auto-Lock option is turned on in the ordinary sewing setting mode (refer to page 139).

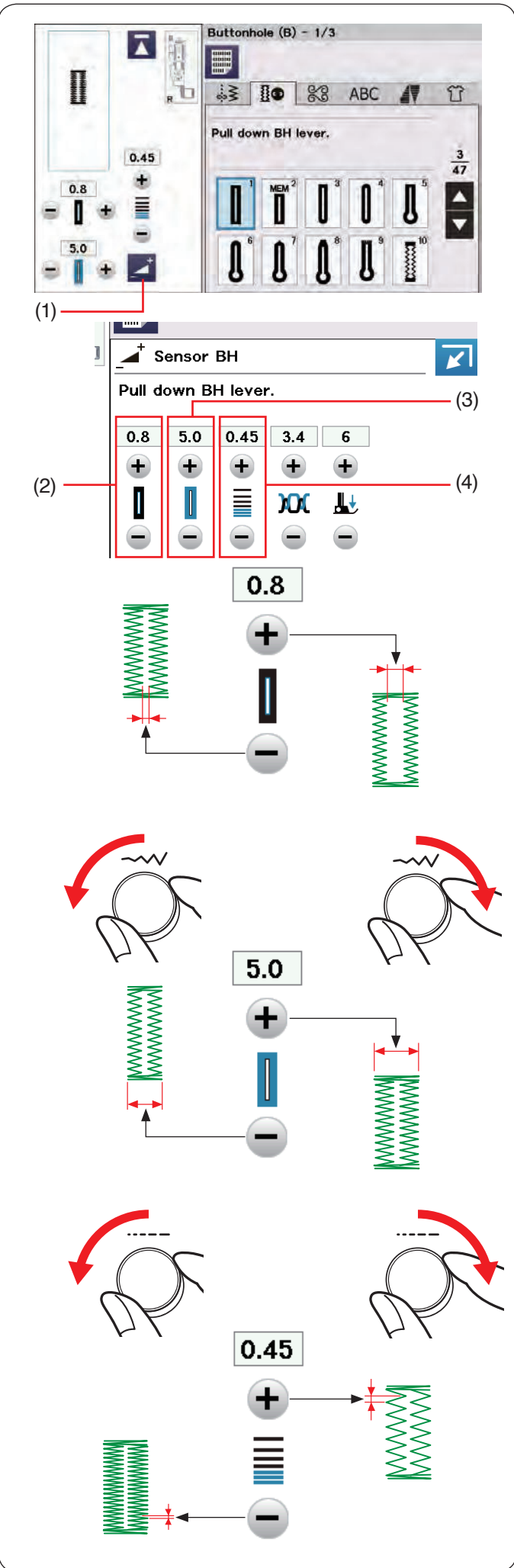

Manual Settings

You can alter the buttonhole opening width, buttonhole width and buttonhole stitch density on the manual setting window.

When you press the adjust key, the manual setting window expands to show more options.

- (1) Adjust key

(2) Altering buttonhole opening width

Press the “+” key to make the buttonhole opening wider. Press the “-” key to make the buttonhole opening narrower.

(3) Altering buttonhole width

Turn the stitch width adjusting dial clockwise to increase the buttonhole width.

Turn the stitch width adjusting dial counterclockwise to decrease the buttonhole width.

Or press the “+” key to increase the buttonhole width. Press the “-” key to decrease the buttonhole width.

(4) Altering buttonhole stitch density

Turn the stitch length adjusting dial clockwise to make the buttonhole stitches less dense.

Turn the stitch length adjusting dial counterclockwise to make the buttonhole stitches denser.

Or press the “+” key to make the buttonhole stitches less dense.

Press the “-” key to make the buttonhole stitches denser.

NOTE:

- The opening width can be adjusted from 0.2 to 2.0.
- The buttonhole width can be adjusted from 2.6 to 9.0.
- The stitch density can be adjusted from 0.20 to 1.00.

1.

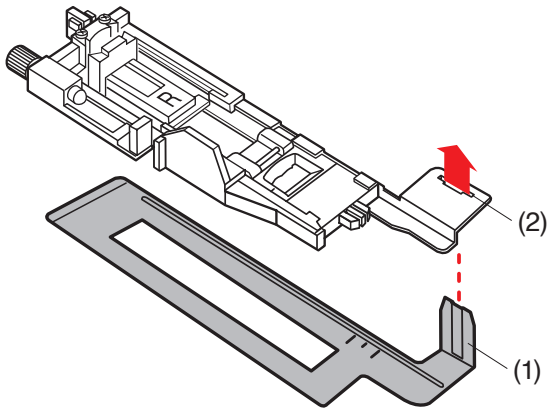

2.

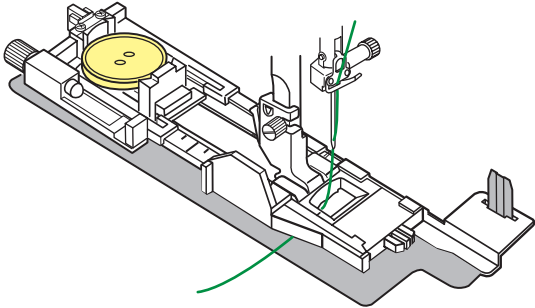

3.

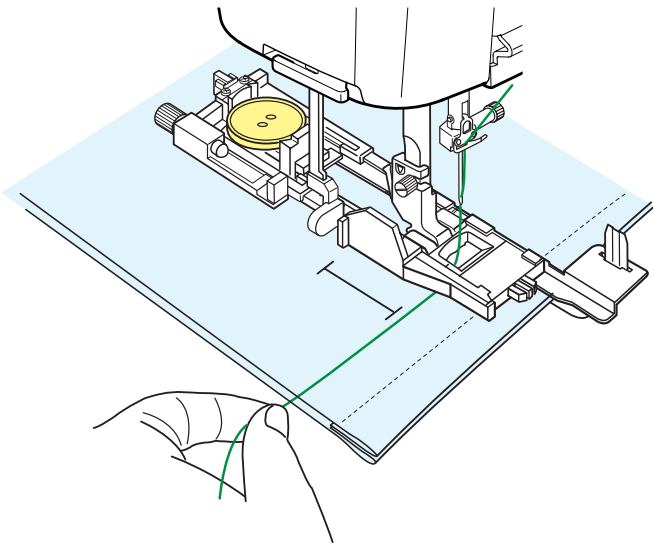

Using the Stabilizer Plate

The stabilizer plate holds and supports the fabric so it is helpful when sewing buttonholes over the hem of thick fabrics.

1. Insert the tab of the stabilizer plate into the slot of the buttonhole foot.

- (1) Stabilizer plate
- (2) Slot

2. Place the button on the button holder of the foot. Attach the buttonhole foot to the machine.

Draw the needle thread to the left between the foot and stabilizer plate.

3. Place the fabric between the buttonhole foot and stabilizer plate. Lower the needle into the starting point by turning the handwheel.

Lower the foot and buttonhole lever.

Start the machine while pulling the needle thread lightly to the left. After sewing a few stitches, free the thread and continue sewing.

NOTE:

The sewing procedure is exactly the same as that for B1 sensor (square) buttonhole (refer to pages 57-59).

Buttonhole (B) - 1/3

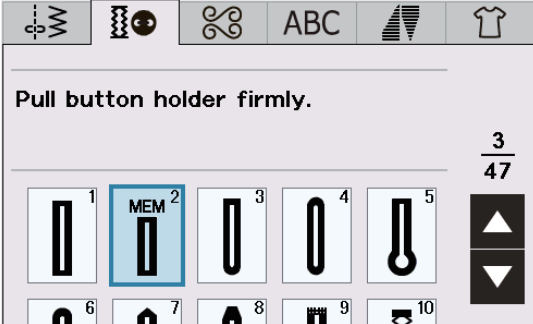

Pull button holder firmly.

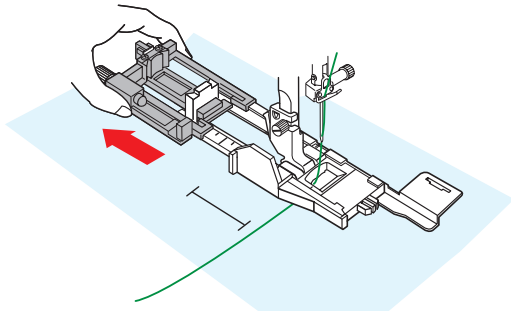

1.

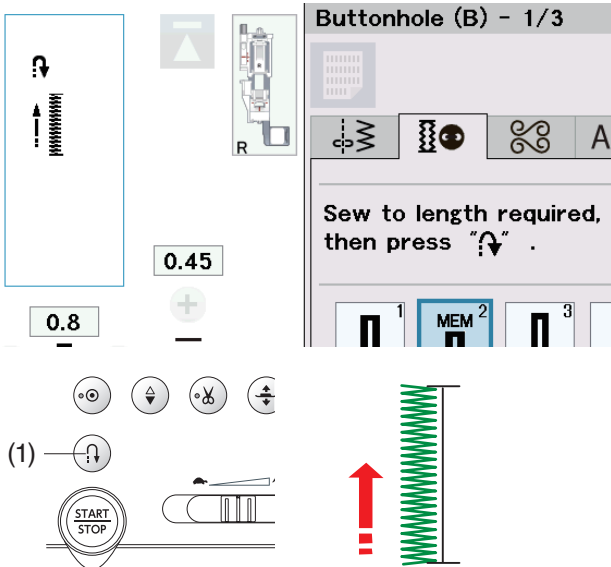

2.

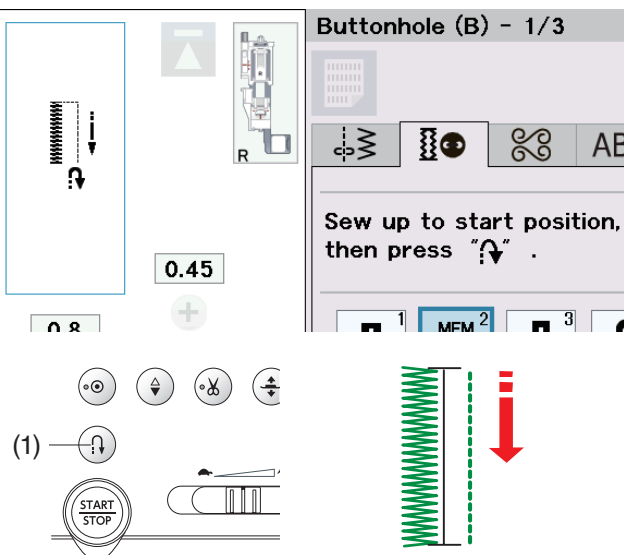

B2 Automatic (Square) Buttonhole

Pull the button holder all the way out.

Draw the needle thread to the left through the hole of the foot.

Mark the buttonhole position on the fabric.

Place the fabric under the foot, and lower the needle at the starting point by turning the handwheel.

Lower the foot and start sewing while pulling the needle thread lightly to the left. After sewing a few stitches, free the thread and continue sewing.

NOTE:

- You do not need to pull down the buttonhole lever.
- If you wish to sew a buttonhole longer than the size permitted by the automatic buttonhole foot R, use satin stitch foot F.

NOTE:

- The opening width can be adjusted from 0.2 to 2.0.
- The buttonhole width can be adjusted from 2.6 to 9.0.
- The stitch density can be adjusted from 0.20 to 1.00.

1. Sew the left side up to the required buttonhole length and stop the machine. Then press the reverse button.

(1) Reverse button

2. Start sewing again, and the machine sews back with a straight stitch.

Stop the machine when you reach the starting point. Then press the reverse button.

(1) Reverse button

3.

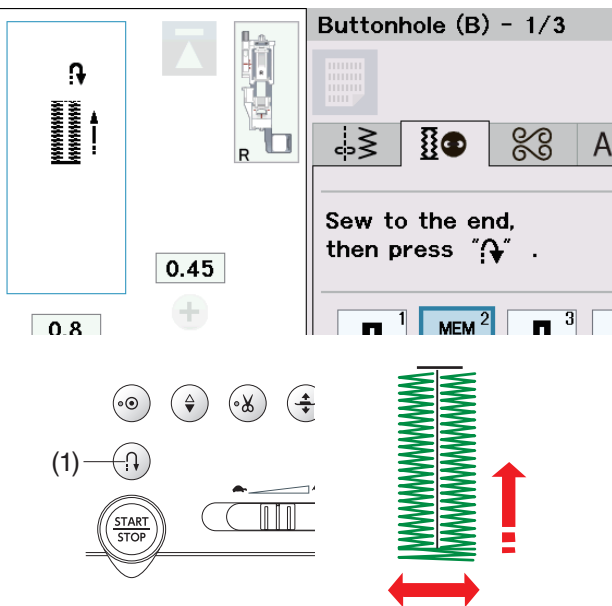

3. Start sewing again, and the machine sews the front bartack and right side of the buttonhole.
Stop the machine when you reach the ending point.
Then press the reverse button.

(1) Reverse button

4.

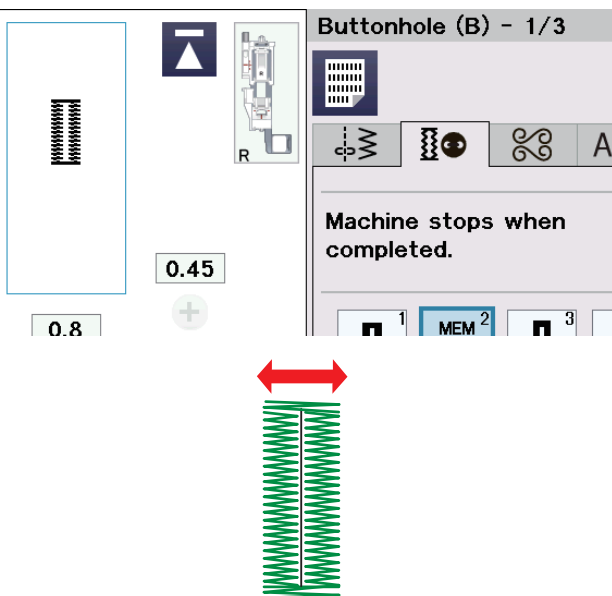

4. Start sewing again, and machine sews the back bartack and locking stitches then stops automatically with the needle in the up position.
When the buttonhole is finished, a message will appear.
To make the next buttonhole, position the fabric and start sewing again. The message disappears and the machine sews another buttonhole identical to the first one then stops automatically.

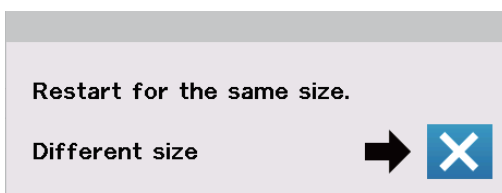

To sew another buttonhole in a different size, press the X key on the dialog box.

NOTE:

- To cut the buttonhole opening, refer to the instructions on page 59.
- The memorized length will be cancelled if the presser foot is raised or the startover key (refer to page 89) is pressed before buttonhole is completed.

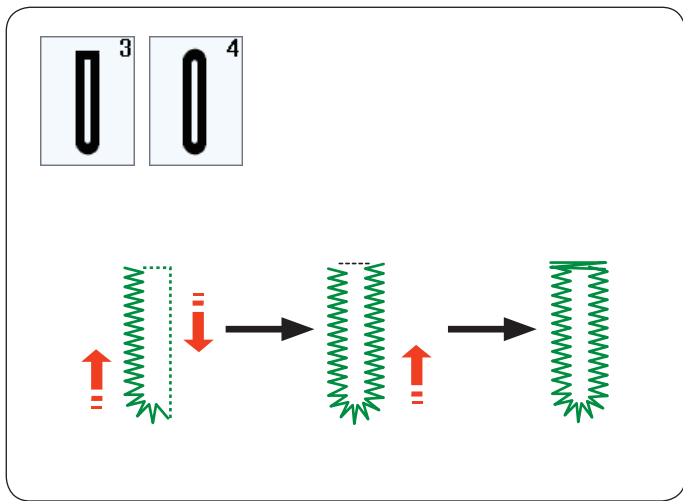

Other Buttonholes

B3, B4 Round end and fine fabric buttonholes

The sewing procedure is the same as that of B1 sensor (square) buttonhole (refer to pages 57-59).

NOTE:

- The opening width can be adjusted from 0.2 to 2.0.
- The buttonhole width can be adjusted from 2.6 to 9.0.
- The stitch density can be adjusted from 0.20 to 1.00.

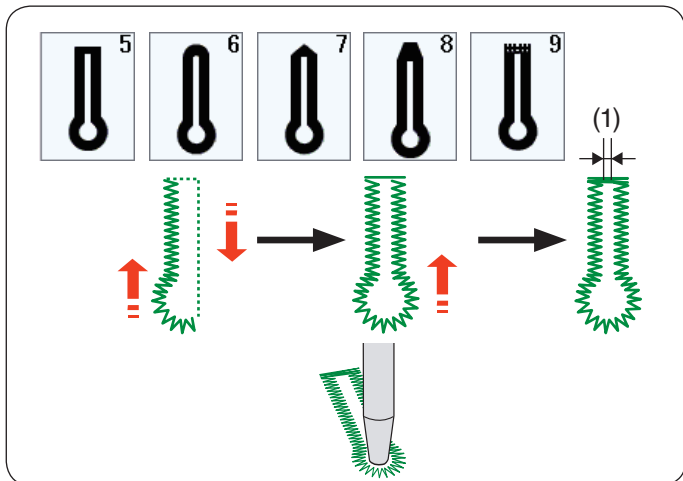

B5-B9 Keyhole buttonholes

The sewing procedure is the same as B1 sensor (square) buttonhole (refer to pages 57-59).

Use a punch to open the keyhole buttonhole.

NOTE:

- A punch is not included with this machine.
- The opening width (1) can be adjusted from 0.2 to 2.0.
- The buttonhole width can be adjusted from 5.6 to 9.0.
- The stitch density can be adjusted from 0.20 to 1.00.

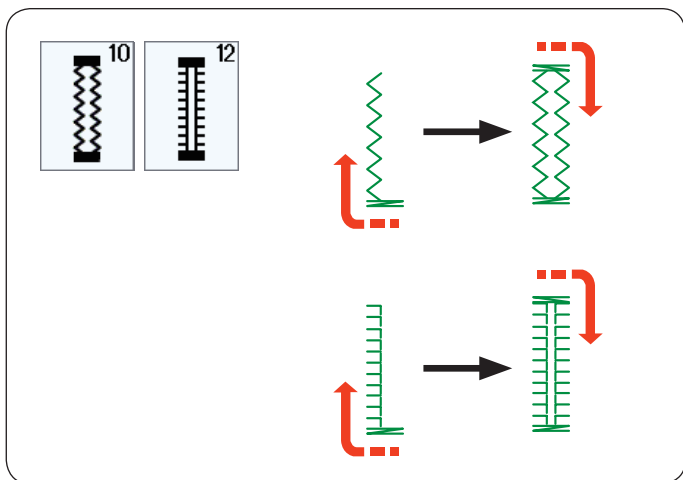

B10, B12 Stretch and Antique buttonholes

The sewing procedure is the same as B1 sensor (square) buttonhole (refer to pages 57-59).

The sewing steps are as shown.

NOTE:

- The opening width can be adjusted from 0.2 to 2.0.
- The buttonhole width can be adjusted from 2.6 to 9.0.
- The stitch density can be adjusted from 0.50 to 1.00 (B10), and from 0.50 to 2.50 (B12).

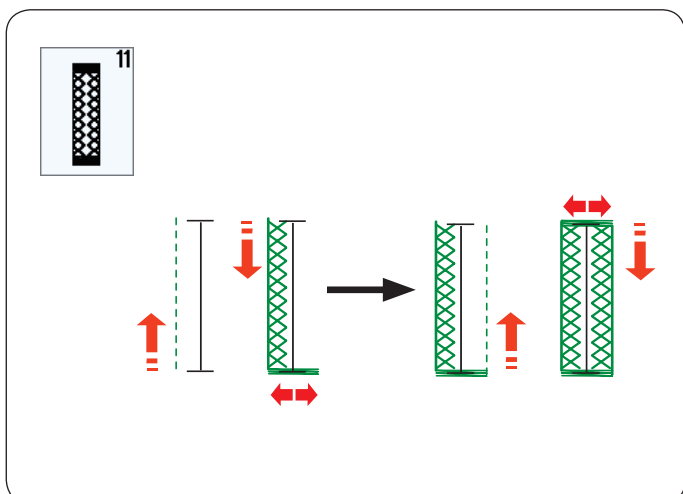

B11 Knit buttonhole

The sewing procedure is the same as B1 sensor (square) buttonhole (refer to pages 57-59).

NOTE:

- The opening width can be adjusted from 0.2 to 2.0.
- The buttonhole width can be adjusted from 2.6 to 9.0.
- The stitch density can be adjusted from 0.70 to 1.20.

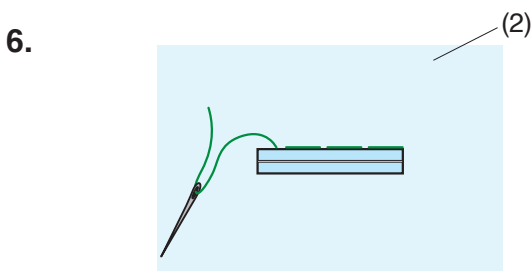
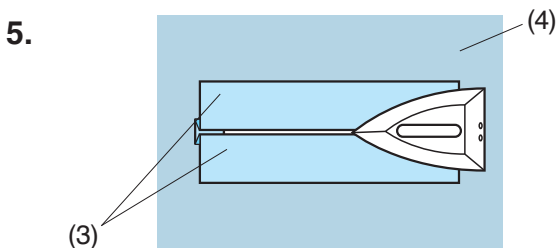
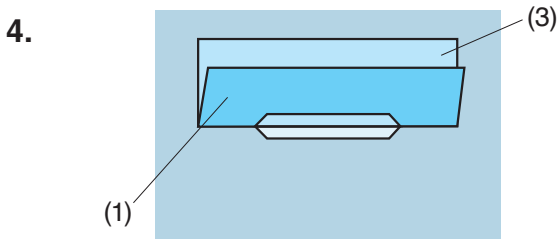
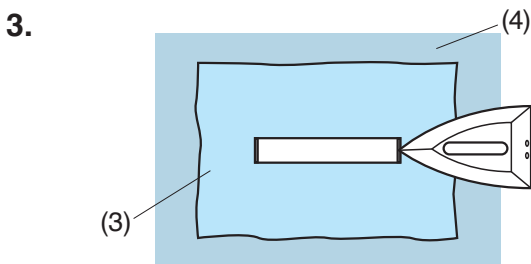
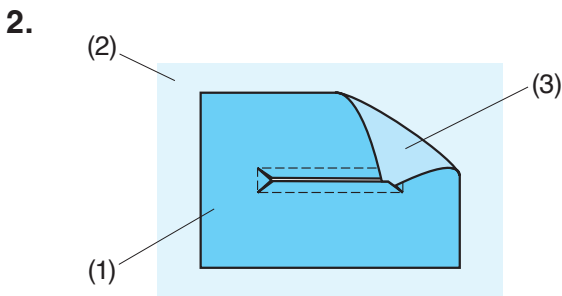
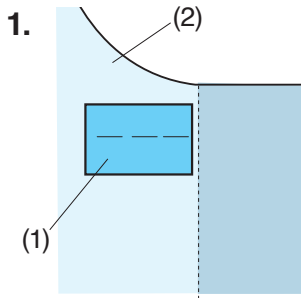
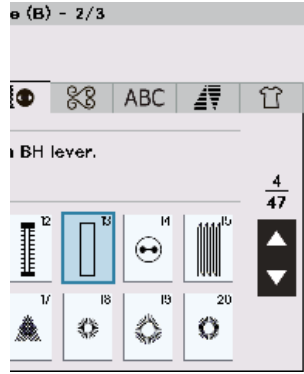
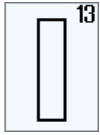

B13 Welted Buttonhole (Bound Buttonhole)

A welted buttonhole is made by stitching a strip or patch of fabric to the buttonhole. Welted buttonholes are particularly suitable for tailored garments, but are not recommended for sheer or delicate fabrics where the patch might show through or add bulk.

1. Baste a patch to the garment fabric with the right sides together.
 - (1) Wrong side of patch
 - (2) Right side of garment fabric

2. Select pattern B13. Sew the welted buttonhole on both fabrics together. Cut the buttonhole opening as illustrated then pull the patch out through the slit to the other side.
 - (1) Wrong side of patch
 - (2) Right side of garment fabric
 - (3) Right side of patch

3. Pull out the patch until the right side of the patch is showing. Use an iron to press both corner ends until they are squared off.
 - (3) Right side of patch
 - (4) Wrong side of garment fabric

4. Fold back each side of the patch to form buttonhole lips.
 - (1) Wrong side of patch
 - (3) Right side of patch

5. Press both folds with an iron.
 - (3) Right side of patch
 - (4) Wrong side of garment fabric

6. Baste both edges of the seam with a needle and thread by hand.
 - (2) Right side of garment fabric

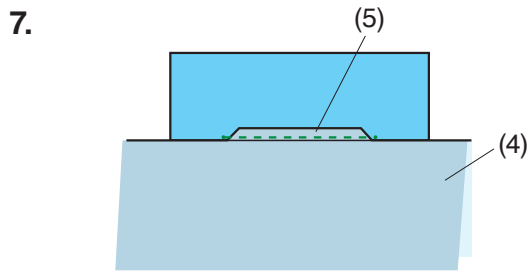

7. Fold over the length of the garment fabric, sew back and forth beside the original seam to secure flaps of the patch.

- (4) Wrong side of garment fabric
- (5) Sew back and forth

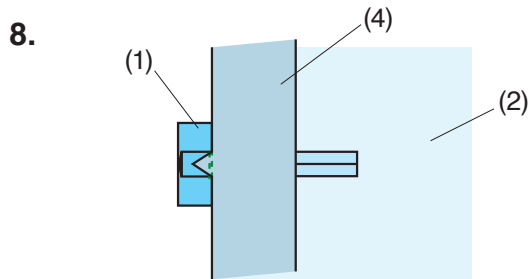

8. Fold over the end of fabric and sew back and forth three times over the triangular end.

- (1) Wrong side of patch
- (2) Right side of garment fabric
- (4) Wrong side of garment fabric

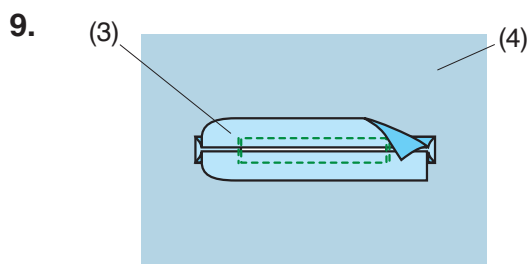

9. The patch should be cut 1 cm to 1.5 cm (7/16" – 5/8") away from the hole. The corners should be cut rounded off as shown.

- (3) Right side of patch
- (4) Wrong side of garment fabric

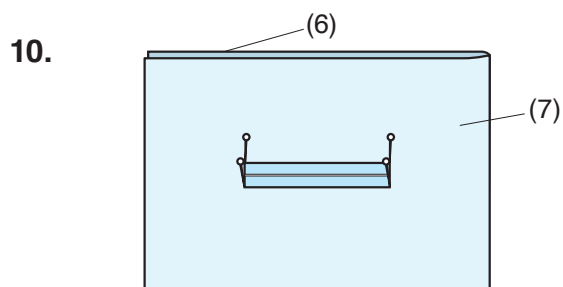

10. Place the facing on the wrong side of the garment fabric. Mark the 4 corners with pins as shown.

- (6) Facing
- (7) Garment fabric

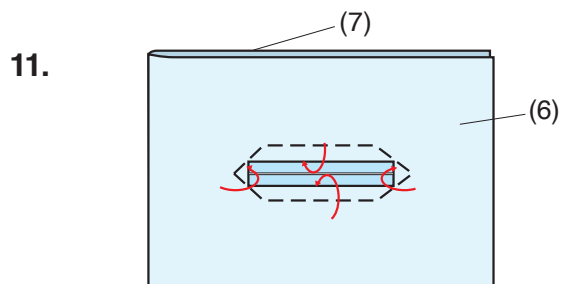

11. Turn all the layers over and cut the buttonhole opening on the facing in the same way as step 2. Four marker pins show you the corner points on the facing. Fold back each flap between the facing and patch.

- (6) Facing
- (7) Garment fabric

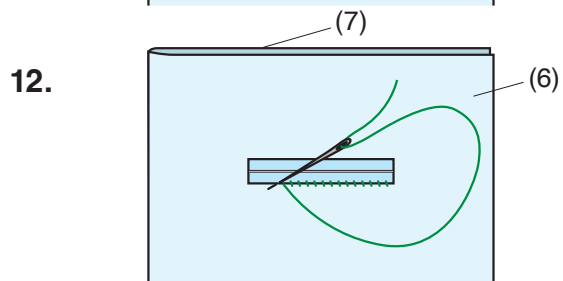

12. Stitch around the opening with a needle and thread as shown.

- (6) Facing
- (7) Garment fabric

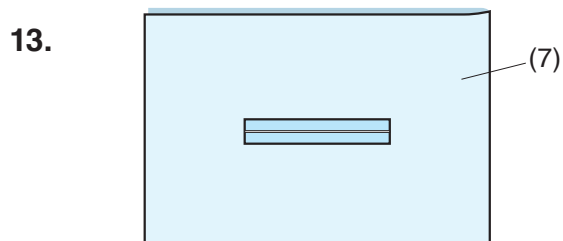

13. The welted buttonhole is complete.

- (7) Garment fabric

1.

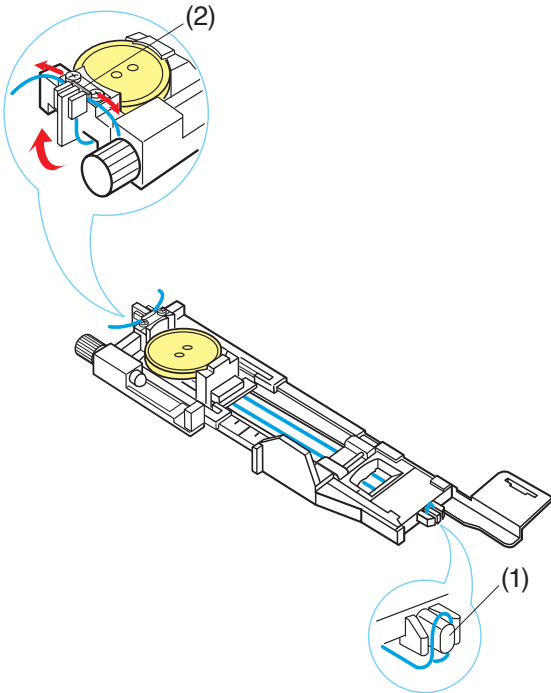

2.

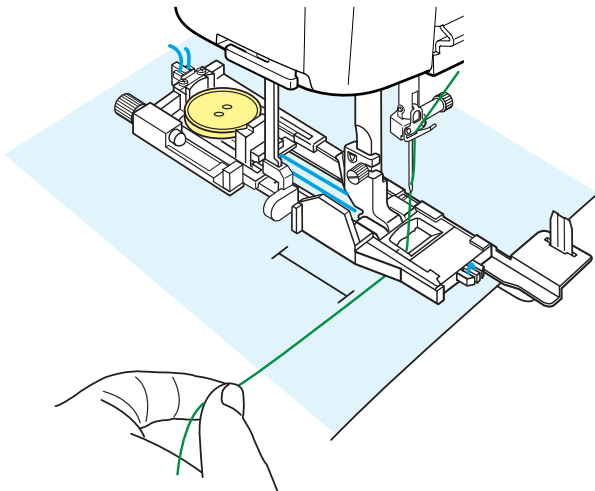

3.

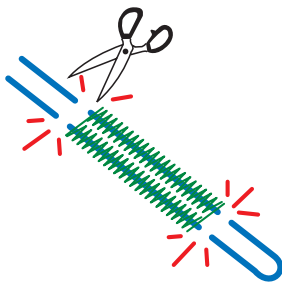

Corded Buttonhole

To sew a corded buttonhole, follow the same procedure as for B1 sensor (square) buttonhole.

Select pattern B1.

1. Place the button on the button holder on the buttonhole foot.
Hook a filler cord on the spur on the front of the foot. Bring the ends of cord toward the back and under the foot.
Bring up the ends of the cord and insert both ends between the ribs and metal plate.

- (1) Spur
- (2) Metal plate

Set the stabilizer plate as necessary and attach the buttonhole foot.

2. Lower the needle into the fabric where the buttonhole will start.

Lower the foot and buttonhole lever.
Pull the needle thread lightly to the left.
Start the machine to sew the buttonhole over the cord.
The machine stops automatically when finished.
Remove the fabric from the machine and cut the sewing threads only.

3. Cut the filler cord at both ends as close to the buttonhole as possible.

NOTE:

- Do not adjust the opening width wider than 0.8.
- Set the stitch width in accordance with the thickness of the cord used.
- To cut the buttonhole opening, refer to the instructions on page 59.

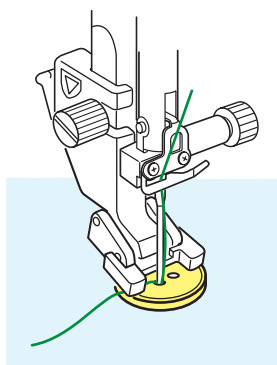

Specialty Stitches

B14 Button Sewing

Refer to page 119 for sewing instructions.

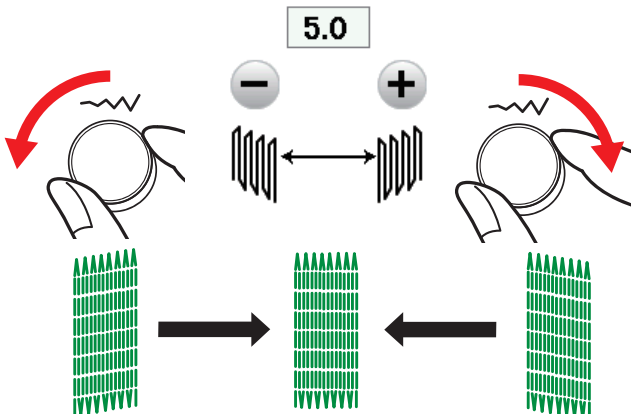
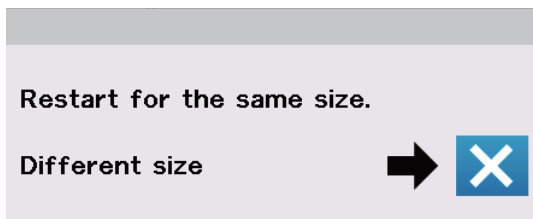
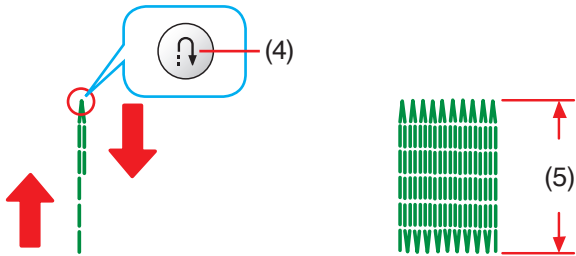
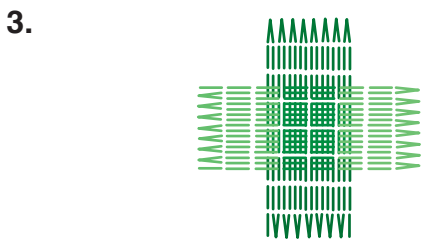
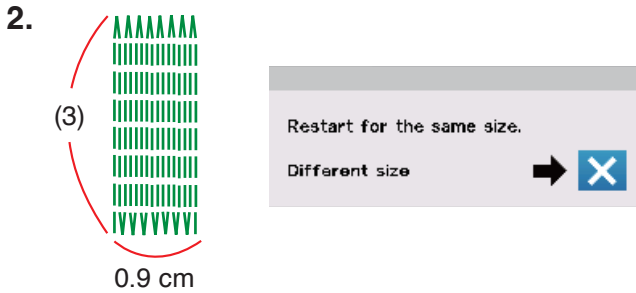
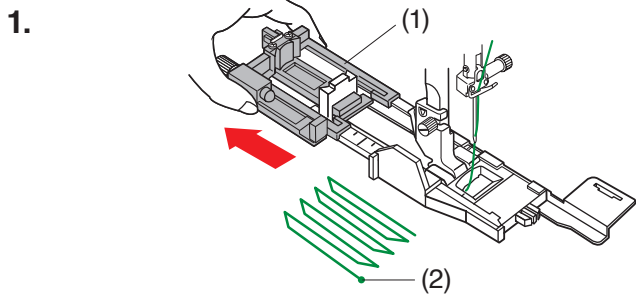

B15 Darning

1. Attach the automatic buttonhole foot R and pull the button holder all the way out.
Place the fabric under the foot, and lower the needle at the starting point. Then lower the foot.

- (1) Button holder
- (2) Starting point

2. Start the machine and continue sewing until the machine stops automatically. When finished sewing, a confirmation message will appear.

NOTE:

The machine will sew the darning at maximum 2 cm (3/4") length and fixed 0.9 cm (3/8") width when sewing until it stops automatically.

- (3) 2 cm (3/4")

3. Sew another layer of darning over the first layer, at a right angle to it.

To sew a shorter darning

Sew the first line to the desired length and stop the machine.

Press the reverse button and start the machine again. The machine will sew the rest of the darning and stop automatically.

- (4) Reverse button
- (5) Required length

To sew the same size darning

When finished sewing, a confirmation message will appear.

Simply start the machine to sew another layer of darning stitches in the same size.

To sew the next layer of darning stitches in a different size, press the X key.

To adjust the evenness of darning stitches

You can correct unevenness of darning stitches by turning the stitch width adjusting dial or pressing the “-” or “+” key.

If the left corner is lower than the right side, turn the stitch width adjusting dial counterclockwise or press the “-” key to correct it.

If the right corner is lower than the left side, turn the stitch width adjusting dial clockwise or press the “+” key to correct it.

NOTE:

The memorized length will be cancelled if the presser foot is raised or the startover key (refer to page 89) is pressed before darning is completed.

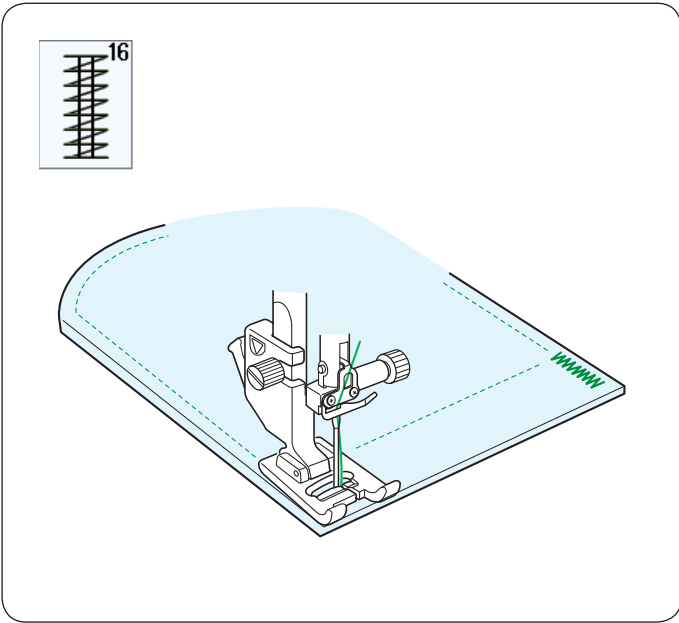
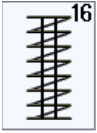

B16 Tacking

Refer to page 120 for sewing instructions.

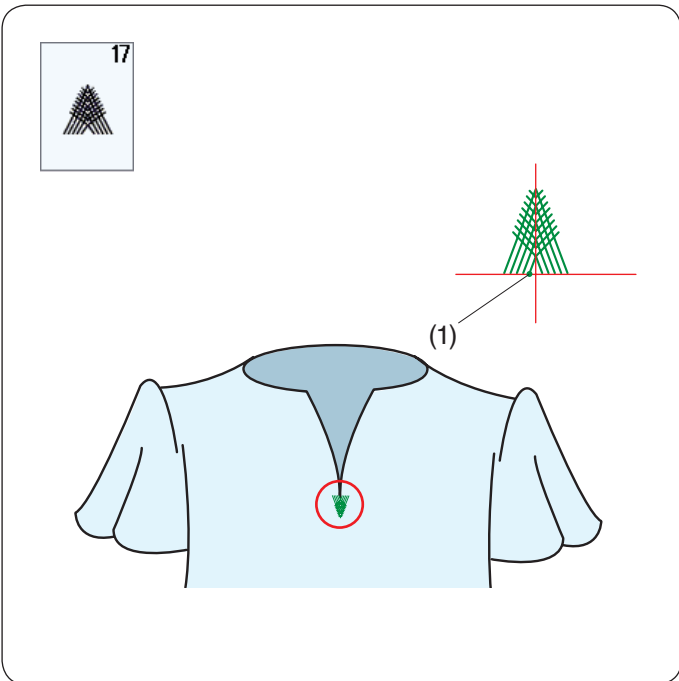

B17 Fly Stitch

The fly stitch is a triangle tacking stitch for use on a zipper fly bottom and on the side pockets of pants.

Attach the satin stitch foot F.

To sew:

Place the garment under the foot and lower the needle at the starting point.

Sew the stitch until the machine stops automatically.

(1) Starting point

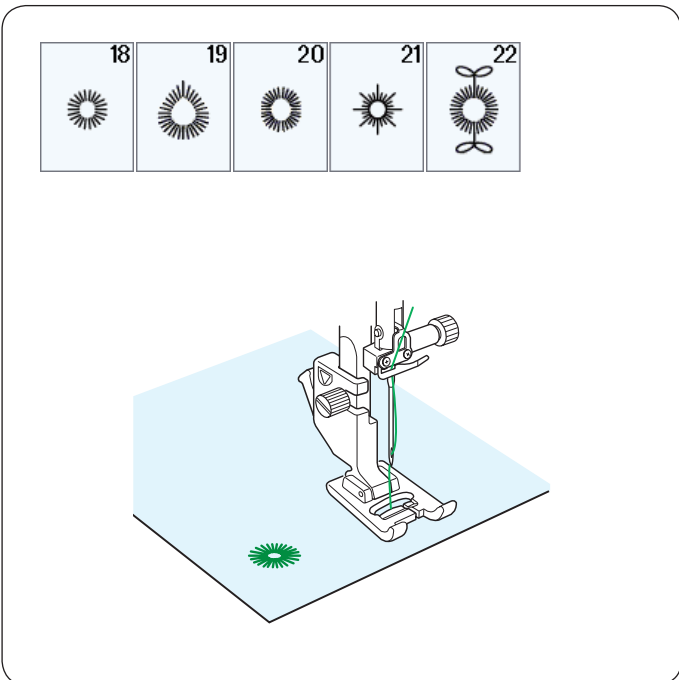

B18-B22 Eyelets

Refer to page 121 for sewing instructions.

DECORATIVE STITCHES

Decorative Stitches

Press the decorative and quilting stitches tab and the category selection window will open.

(1) Decorative and quilting stitches tab

The patterns in this section are classified into 17 groups. These patterns are programmable and you can make a pattern combination.

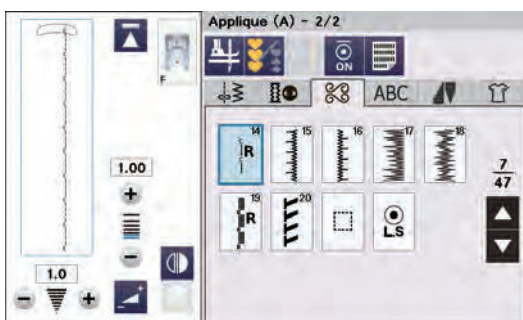
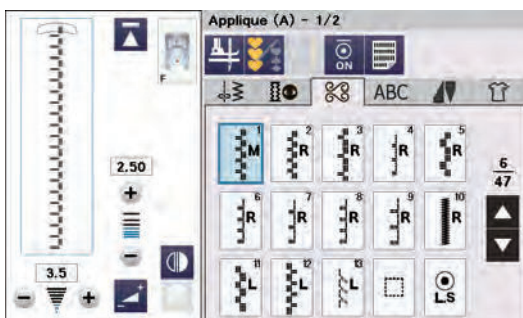
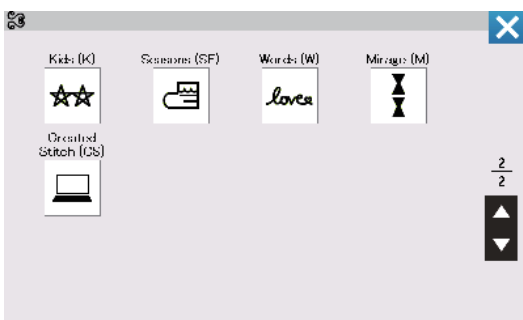
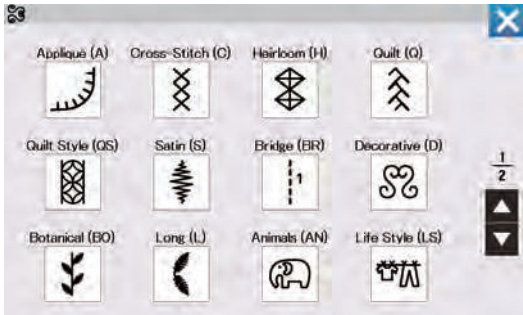
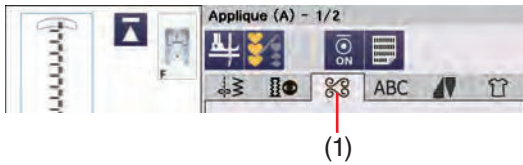

Applique (A): 2 pages

Stitches in this group are for applique (Refer to page 130).

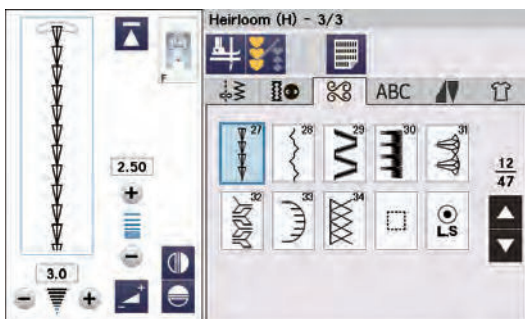
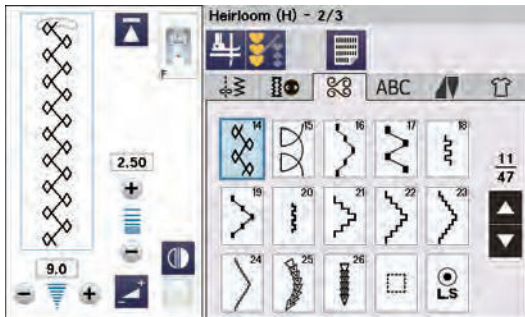
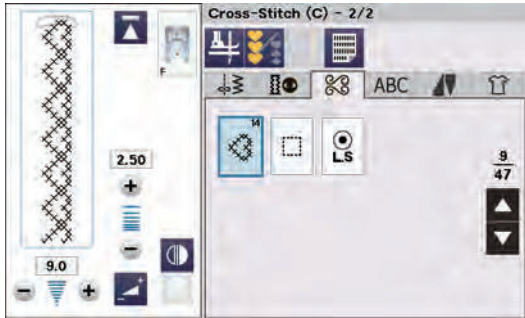

Cross-Stitch (C): 2 pages

This group provides cross-stitches for craft sewing and home décor.

Heirloom (H): 3 pages

This group provides heirloom stitches for craft sewing and home décor.

Quilt (Q): 8 pages

Stitches in this group are for patchwork and quilting
(Refer to pages 79, 82, 123-132).

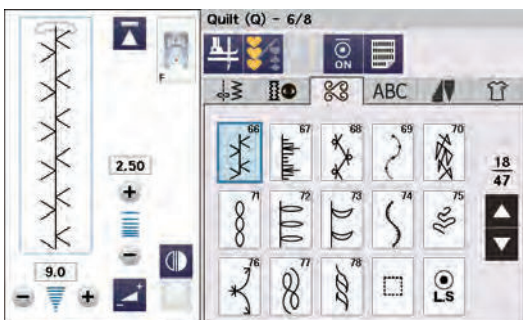
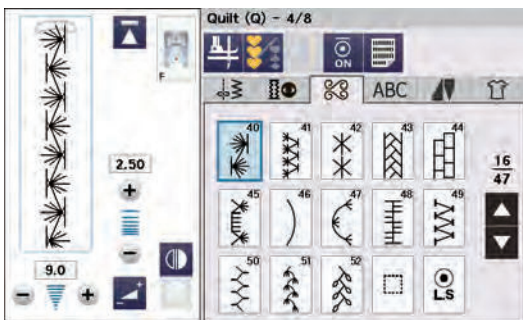
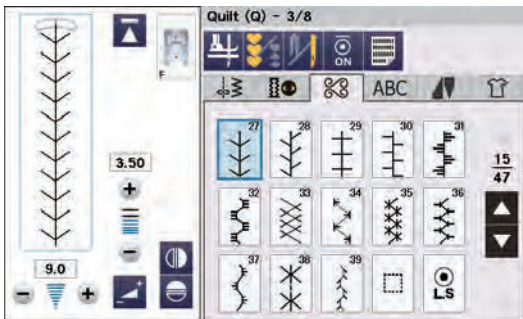
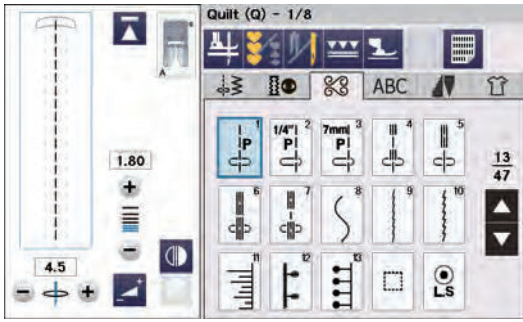

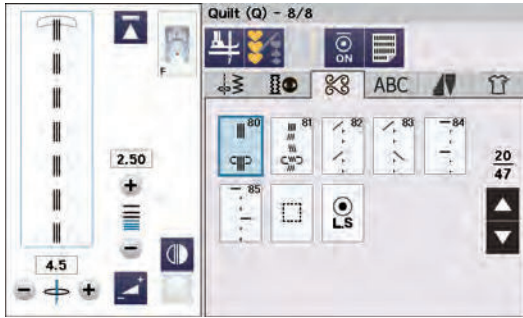
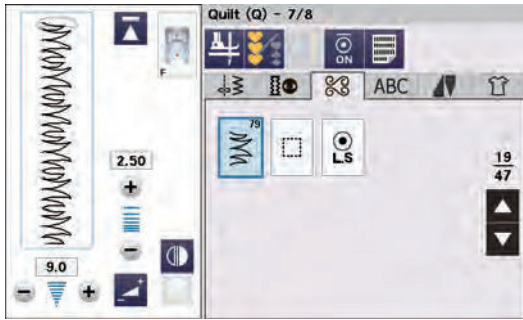

Quit Style (QS): 1 page

There are stitch patterns created from quilt blocks in this group.

Satin (S): 3 pages

The stitches in this group can be elongated up to 5 times their original length while the stitch density remains the same (refer to page 82).

Satin (S) (continued from previous page)

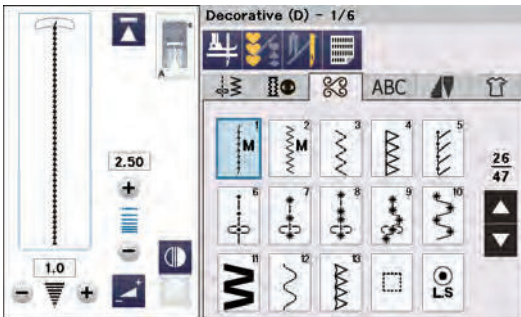
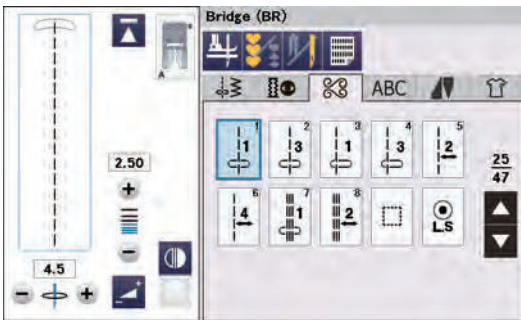

Bridge (BR): 1 page

Bridge stitches are used for inserting straight stitches after a stitch pattern.

The number beside the stitch image on the straight stitch key indicates the stitch count of a programmable unit. Patterns BR5, BR6 and BR8 will inherit the needle drop position and stitch length of the previous pattern in the programmed pattern combination (refer to page 87).

Decorative (D): 6 pages

64 attractive patterns are available in this group. Patterns in this group are ideal for decorating.

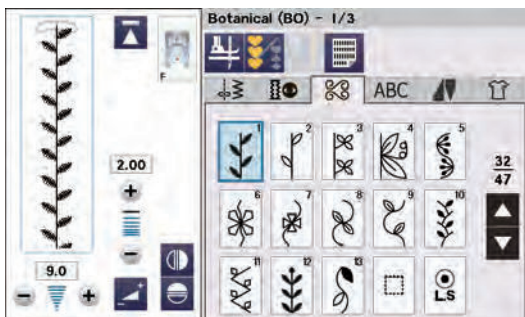
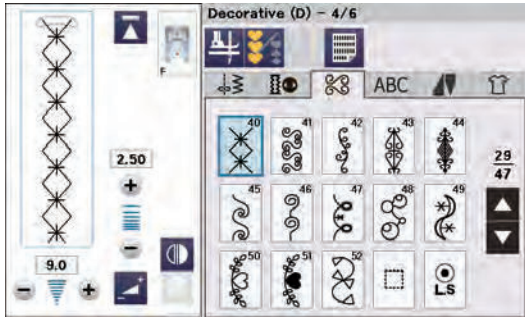
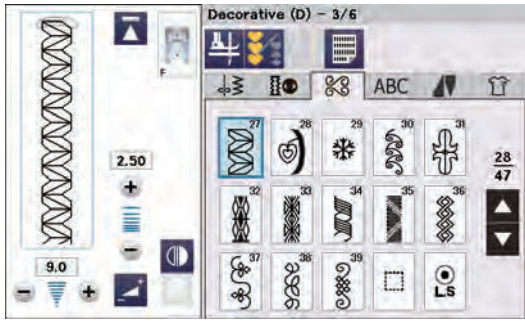

Botanical (BO): 3 pages

There are patterns of trees, grass and flowers in this group.

Botanical (BO) (continued from previous page)

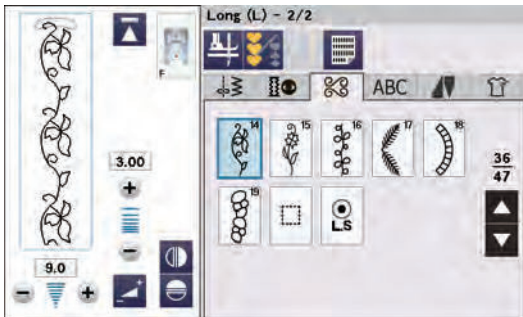
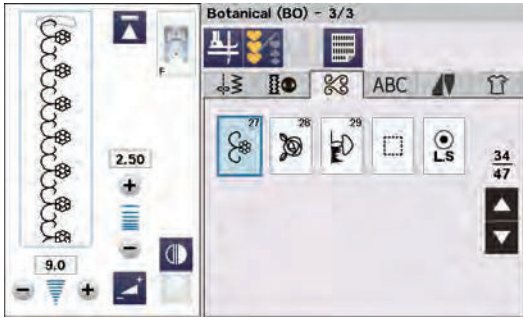
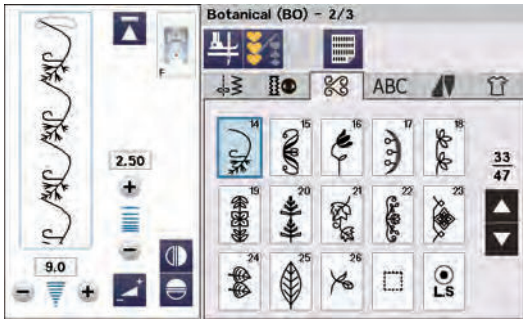

Long (L): 2 pages

Patterns in this group are ideal for decorating garments and for adding border trims.

Animals (AN): 1 page

There are patterns of animals in this group.

Life Style (LS): 3 pages

There are patterns related to lifestyle in this group.



Kids (K): 2 pages

There are patterns for kids in this group.

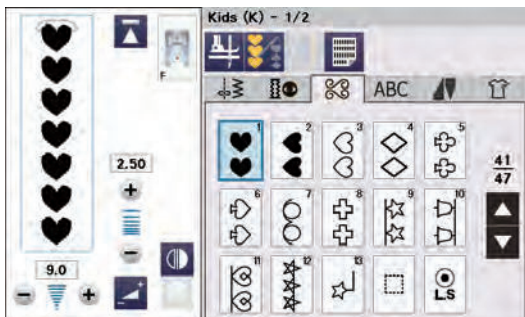

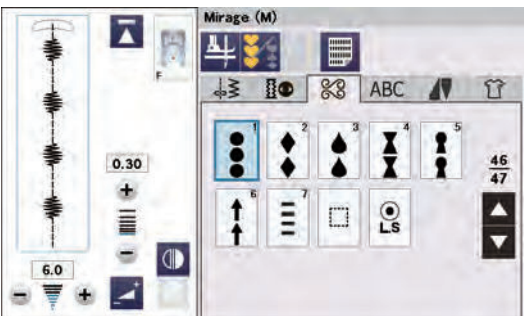
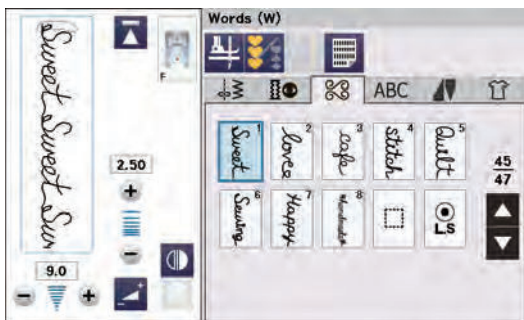
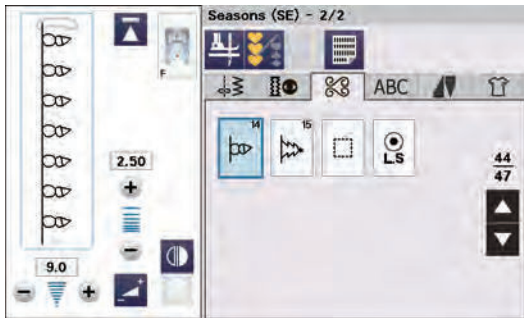

Seasons (SE): 2 pages

There are patterns related to seasons in this group.

Words (W): 1 page

There are word patterns in this group.

Mirage (M): 1 page

This group provides satin patterns without connecting straight stitches (refer to page 83).

Created Stitch (CS): 1 - 5 pages

In this section, you can select original stitch patterns created with StitchComposer.

Refer to page 84 for how to transfer created stitch patterns from a PC to the machine.

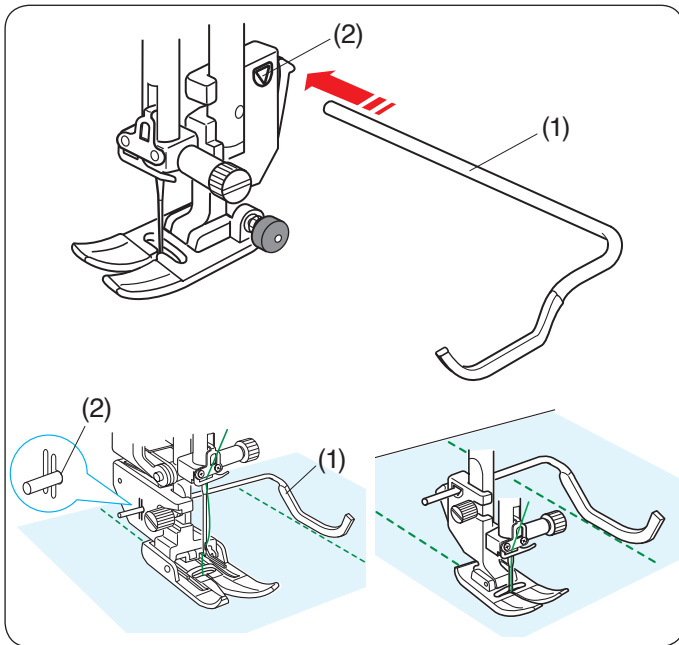

Quilting

Using the Quilting Guide Bar

The quilting guide bar is helpful when sewing parallel, evenly spaced rows of stitches.

Insert the quilting guide bar into the hole in the back of the foot holder. Slide the quilting guide bar and set it to the desired spacing.

- (1) Quilting guide bar
- (2) Hole

Sew rows of stitches while tracing the previous row of stitches with the quilting guide bar.

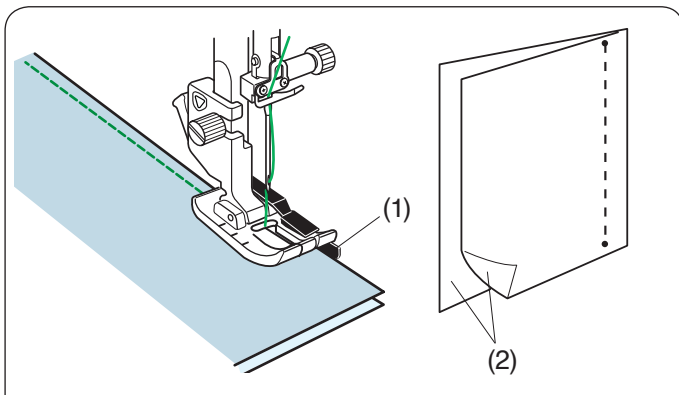

Q1-Q3 Patchwork Piecing

Patterns Q1 to Q3 are special stitches for seaming patchwork pieces.

Patterns Q2 and Q3 are for patchwork piecing with 1/4" and 7 mm seam allowances respectively.

Use 1/4" seam foot O.

Place the patchwork pieces with the right sides together. Sew while guiding the edge of fabric along the guide.

- (1) Guide
- (2) Right side of the fabric

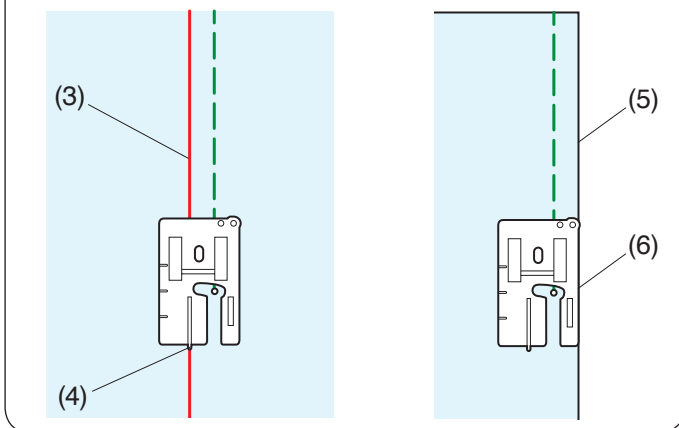

You can sew a 1/4" allowance from the guide line with 1/4" seam foot O (without guide) as shown.

Align the guide line with the 1/4" guide of the foot and sew.

- (3) Guide line
- (4) 1/4" guide

To sew 1/4" seam allowance from the right fabric edge, align the right edge of the foot and the edge of the fabric and sew.

- (5) Right fabric edge
- (6) Right edge of the foot

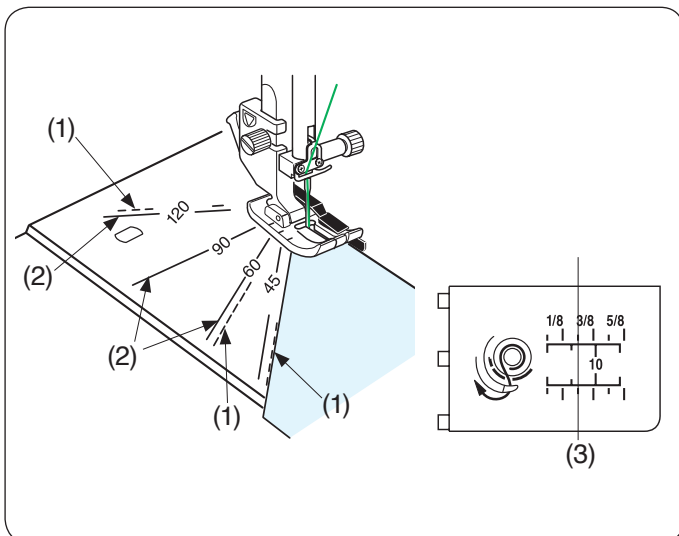

Angle Scales on the Needle Plate

You can easily seam patchwork pieces at the desired angle without marking, by using the angle scales on the needle plate.

The angle scales are marked at 45, 60, 90 and 120 degrees.

Use the broken lines when piecing the patchwork pieces with 1/4" seam foot O as illustrated.

- (1) Broken line

NOTE:

Use the solid lines when piecing the patchwork pieces with zigzag foot A. Align the edge of the fabric to the 1/4" seam guide line.

- (2) Solid line
- (3) 1/4" seam guide line

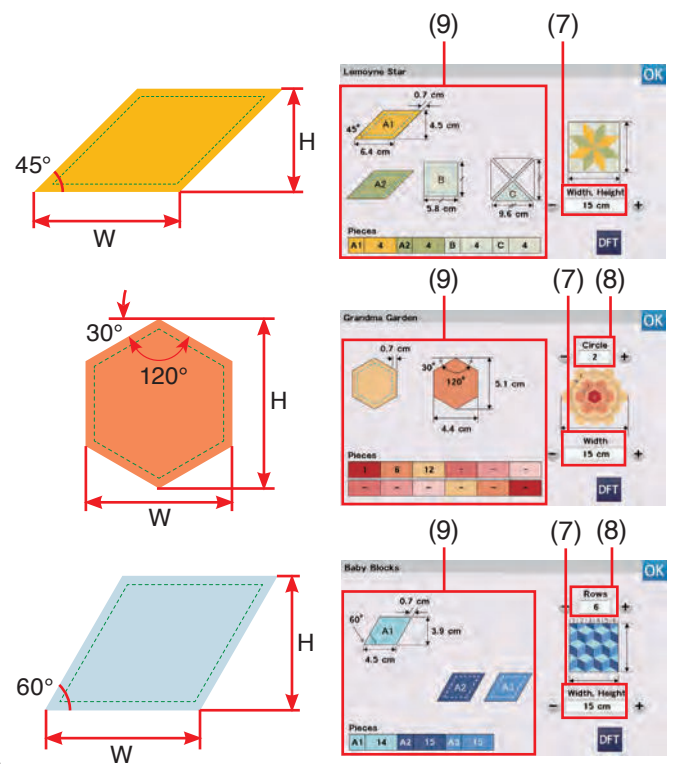
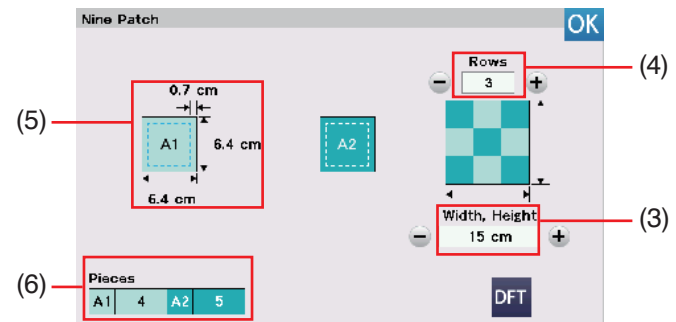
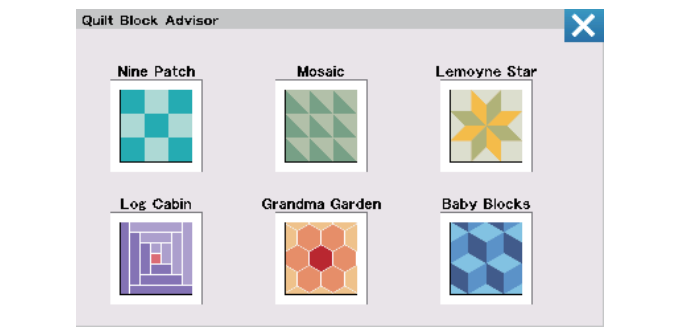
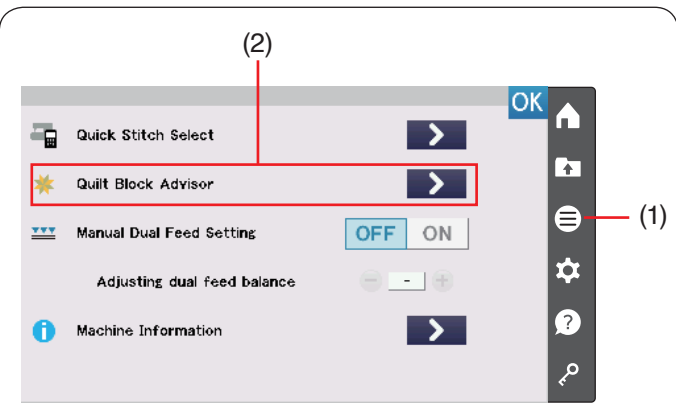

Quilt Block Advisor

The size and number of each piece of fabric can be calculated automatically. There are 6 different quilt patterns available.

Press the Function menu key to open the function menu. Press the key  of the Quilt Block Advisor.

- (1) Function menu key
- (2) Quilt Block Advisor

You can select the following quilt patterns.

Select the design by pressing the quilt key you wish to sew.

- Nine Patch
- Mosaic
- Lemoyne Star
- Log Cabin
- Grandma Garden
- Baby Blocks

Example: Nine patch size calculation

Press the nine patch key to select the nine patch.

Set the size of work (the size of width or the height) in centimeter by pressing the “-” or “+” key.

Set the number of rows by pressing the “-” or “+” key.

- (3) Size of work (Width and Height of the work)
- (4) Number of rows

The size of a piece (seam allowance 0.7 cm is included) and required number of pieces are shown at the left side of the window.

The quilt block advisor indicates that you need 4 pieces of A1 (6.4 cm x 6.4 cm) and 5 pieces of A2 (6.4 cm x 6.4 cm) to make the nine patch quilt (3 rows, 15 cm x 15 cm).

- (5) Size of a piece (including the seam allowance 0.7 cm)
- (6) Number of required pieces

Other quilt designs

Select the design by pressing quilt keys you wish to sew. Set the size of work (Width/Height) by pressing the “-” or “+” key.

Set the number of rows or circle by pressing the “-” or “+” key if required.

The quilt block advisor indicates that the size of piece and number of required pieces at the left side of the window.

- (7) Size of work (Width and Height of the work)
- (8) Number of rows or circle
- (9) Left side of the window

1.

Strips (Cut from A1 and A2)

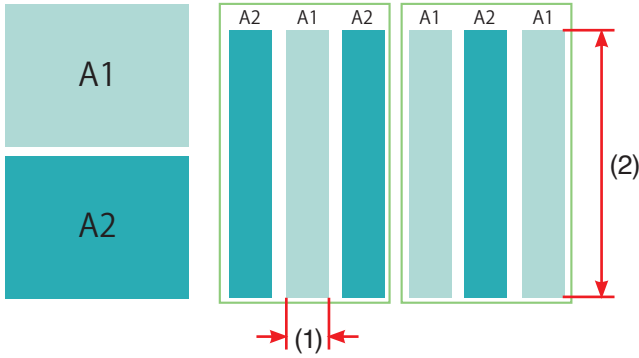

2.

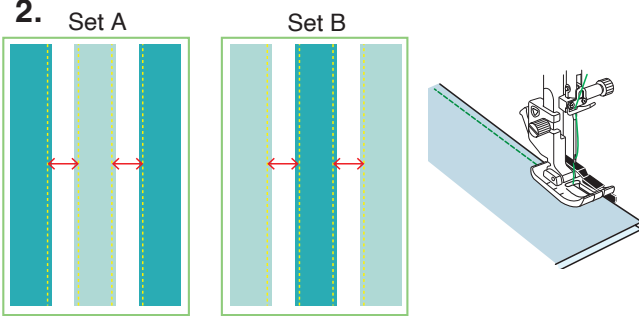

3.

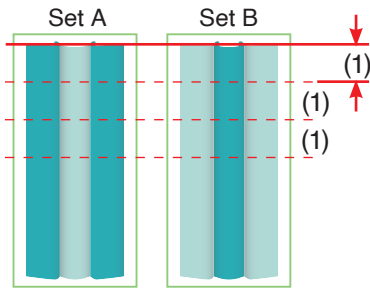

4.

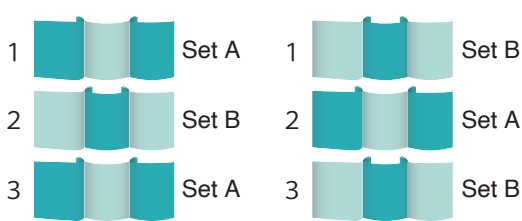

5.

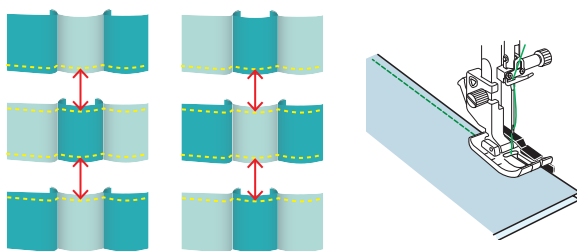

6.

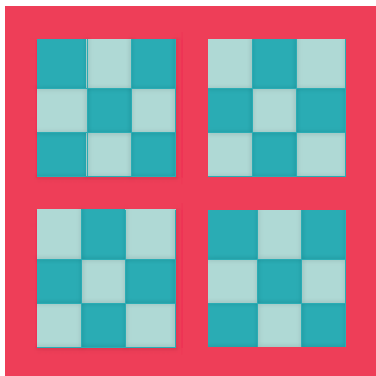

Example: Nine patch quilting

1. Prepare 2 pieces of fabric (A1 and A2) in different colors.
Cut 3 strips of fabric from fabric A1 and 3 strips of fabric from fabric A2. All strips should be the same size. Arrange the A1 and A2 strips alternately.
 - (1) Width of a part of the nine patch piece, including its seam allowance
 - (2) The length of the strip varies depending on the size of the quilting
2. Attach the 1/4" seam foot O.
Stitch the strips with the right sides together to make strip sets A and B as shown in step 3.

NOTE:

Iron the strip sets for better results.
Fold the seam allowance toward the darker fabric.



3. Cut strip sets A and B into width size (1).
4. Arrange set A piece and set B piece alternately to form nine patch quilt block patterns.
5. Stitch set A pieces and set B pieces together.
6. Arrange nine patch pieces as you wish and sew onto a quilt base.



Q80-Q85 Hand-Look Quilt Stitches

Patterns Q80 to Q85 are special stitches for quilting which look like hand sewn stitches.

Use a transparent nylon thread for the needle and ordinary sewing thread for the bobbin.

The bobbin thread is pulled up on the right side of the fabric and the stitches look as if they were sewn by hand.

(1) Adjust key

(2) "+" key

(3) "-" key

(4) Elongation ratio

X1 X2 X3 X4 X5

Satin Stitches

Elongation Ratio

Patterns S1 to S31 are decorative satin stitches for which the pattern length can be elongated without changing the stitch density.

Press the adjust key to expand the manual setting window.

(1) Adjust key

Press the "+" key to elongate the stitch pattern.

(2) "+" key

To reduce the elongation ratio, press the "-" key.

(3) "-" key

The pattern can be elongated up to 5 times the original length.

The elongation ratio is indicated in the box.

(4) Elongation ratio

You can also alter stitch density and stitch width.

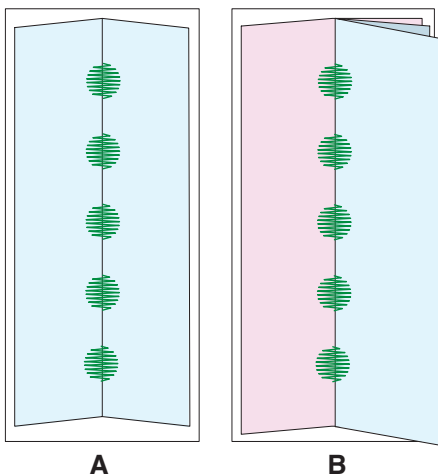
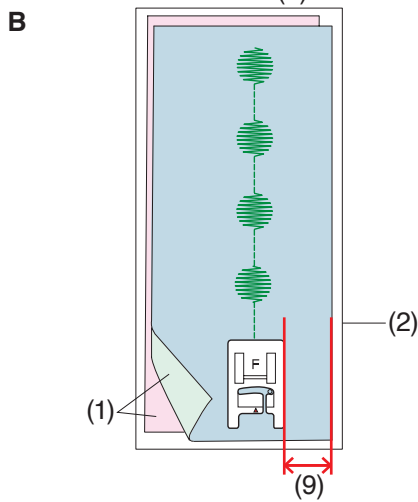
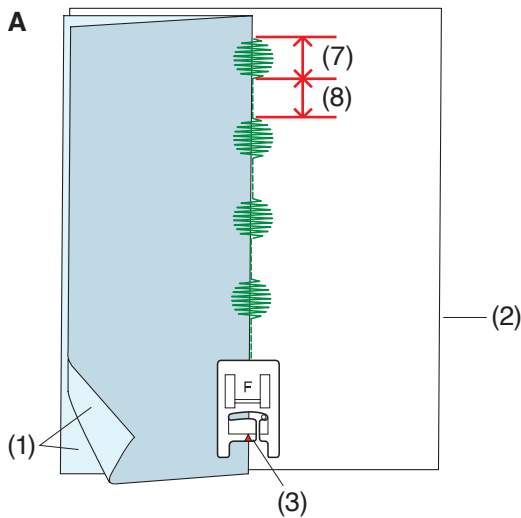
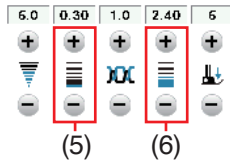
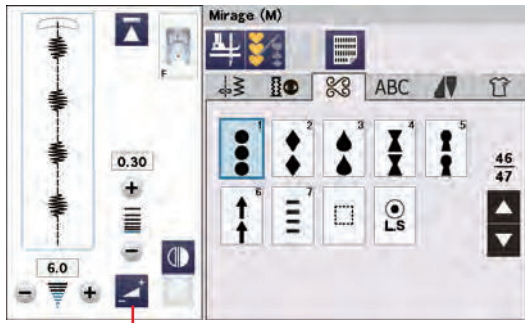

Mirage Stitches

Sew Mirage stitch and open the fabric to make patterns without connecting straight stitches.

NOTE:

Use a medium fabric (such as sheeting, broadcloth) for Mirage stitch patterns. Using fine fabrics may cause wrinkles when opened.

There are two ways to sew the Mirage stitch patterns (sewing on one or two pieces of fabric).

A: Sewing on one piece of fabric

Fold the fabric with the right sides together. Place a sheet of stabilizer under the fabric.

- (1) Right side of the fabric
- (2) Sheet of stabilizer

Attach the satin stitch foot F to the machine.

Sew the Mirage patterns with the marker on the presser foot along the fabric edge as shown.

Sew the connecting straight stitches on the right side of the fabric edge (on the sheet of stabilizer) as shown.

- (3) Marker

In the Mirage stitch, you can adjust the stitch length of the decorative stitch part and connecting straight stitch part separately.

Press the adjust key to expand the manual setting window.

- (4) Adjust key

Adjust decorative stitch length adjusting key or connecting straight stitch adjusting key.

- (5) Decorative stitch length adjusting key
- (6) Connecting straight stitch adjusting key
- (7) Decorative stitch
- (8) Connecting straight stitch

B: Sewing on two pieces of fabrics

Sew the fabric this way when you want to use two different fabrics on the right and left.

Place two pieces of fabric with the right sides together. Place the sheet of stabilizer under the fabric.

- (1) Right side of the fabric
- (2) Sheet of stabilizer

Sew the fabric while keeping a constant seam allowance.

- (9) Seam allowance

Open the fabric flat to hide the connecting straight stitches.

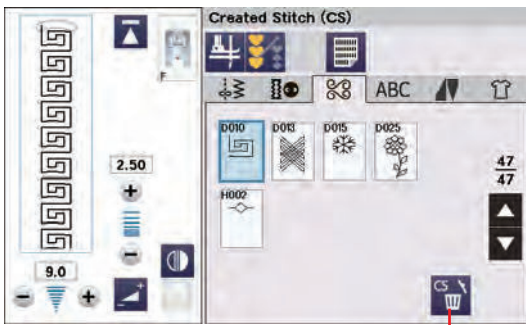
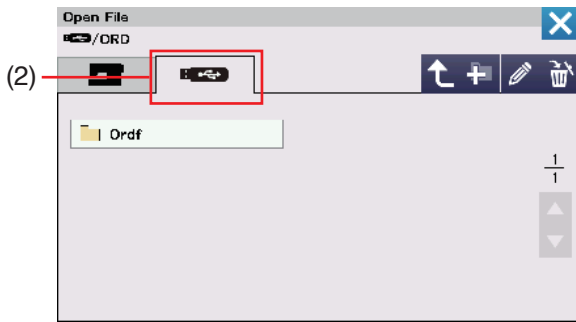
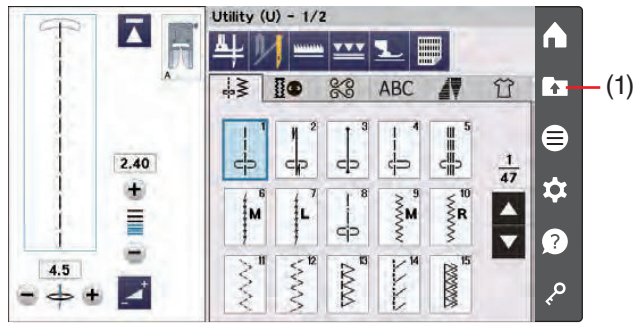

Created Stitches

Original stitch patterns created with StitchComposer are saved in this group (refer to page 7).

Insert the USB flash drive containing the original stitch patterns and press the open file key.

- (1) Open file key

Select the USB key and the folder list will appear.

Select the desired folder to open and the file list will appear.

Select the desired file to save the original stitch pattern.

Saved stitch pattern will appear as the pattern selection key.

You can select, program and sew these patterns the same way as with the built-in stitch patterns.

- (2) USB key

NOTE:

- This model supports FAT16 and FAT32 formats only. If the USB flash drive is not read, check its format (refer to pages 149-150).
- Do not use a USB card reader and USB hub.

To delete a pattern, press the delete key and select the pattern to delete.

A confirmation message will appear. Press the OK key to delete the pattern.

- (3) Delete key

NOTE:

- Up to 60 patterns can be saved in this group.
- Twin needle sewing is not available for the created stitches.

(1)

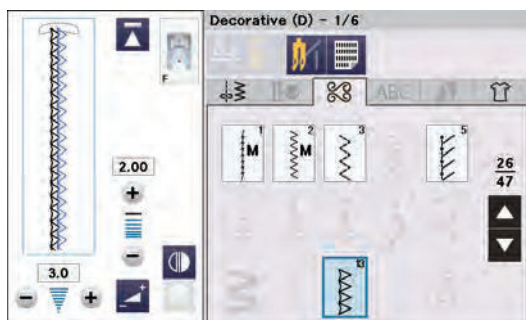
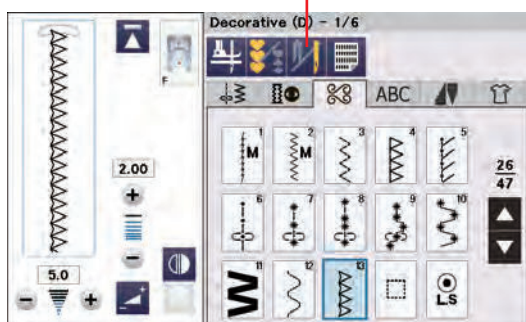

Twin Needle Sewing

Some of the utility stitches and decorative stitches can be sewn with a twin needle.

Press the twin needle key and select the desired pattern.

Patterns not suitable for twin needle sewing cannot be selected (pattern selection keys are grayed out).

Buttonholes, specialty stitches, monogram and tapering cannot be selected.

(1) Twin needle key

NOTE:

- When you sew patterns with the twin needle, test the stitches first before you sew on the garment.
- Use the zigzag foot A or satin stitch foot F for twin needle sewing.
- Use the threads #60 or finer.
- When changing the sewing direction, raise the needle and presser foot then turn the fabric (foot up for pivoting option is not available when the twin needle is selected).
- Use the thread cutter on the face plate when cutting threads.

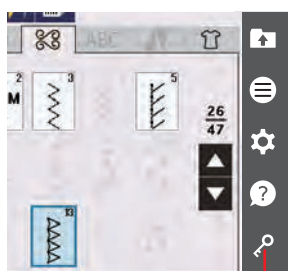

(2)

Replace the needle with the twin needle supplied with the standard accessories (refer to page 24).

CAUTION:

Press the lockout key before changing the needle. Do not use twin needles other than the ones included in the standard accessories, otherwise the needle may hit the needle plate, foot or hook and break.

(2) Lockout key

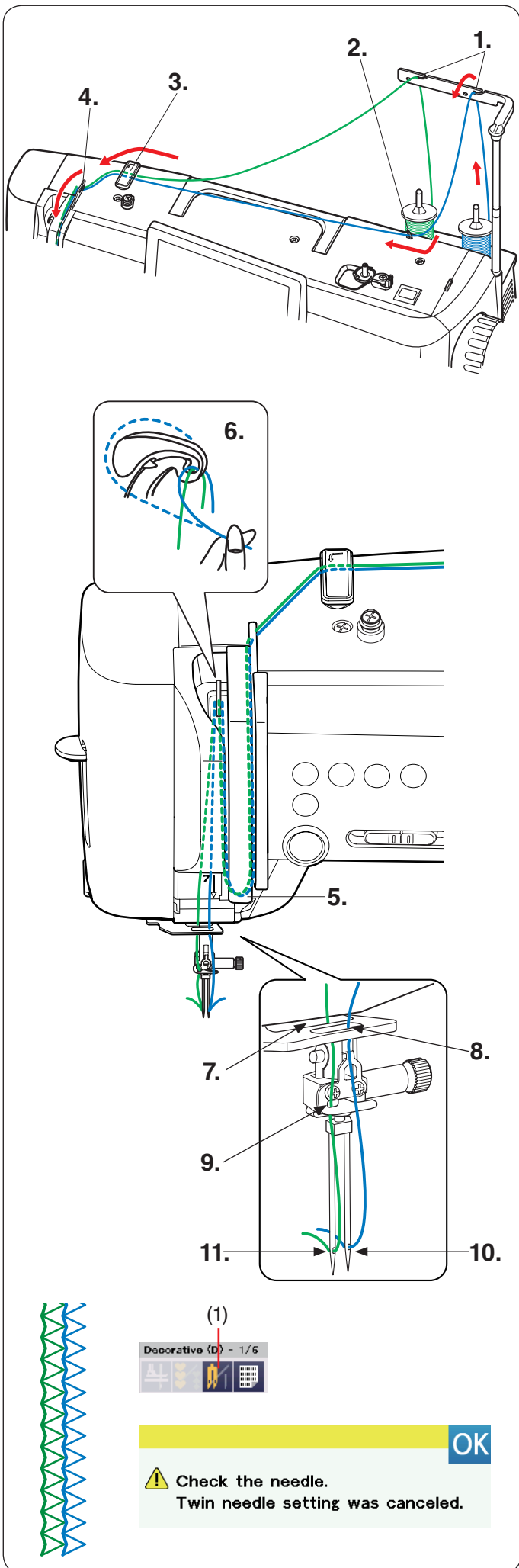

Place two spools of thread on the spool stand.

To thread the left spool thread, draw the thread from the left spool and pass it through the threading points from 1. and 3. to 6.

Slip the thread through the slit of the lower thread guide 7., (behind the hole of the lower thread guide) then pass through points 9. and 11. as illustrated.

To thread the right spool thread, draw the thread from the right spool and pass it through the threading points from 1. to 6.

Draw the thread through the hole of the lower thread guide 8., then pass the thread to the point 10. as illustrated.

Make sure that the two strands of thread from the spools do not get tangled.

NOTE:

- Threading from points 3. to 6. is the same as for a single needle (refer to pages 30-31).
- The needle threader cannot be used with the twin needle.

After twin needle sewing is finished, press the twin needle key and the warning message will appear. Replace the twin needle with a single needle. Press the OK key.

(1) Twin needle key

PROGRAMMING A PATTERN COMBINATION

The patterns in the decorative stitch category and monograms can be programmed to make a pattern combination.

You can program up to 100 patterns in each combination by pressing the program key.

The images of programmed patterns are shown on the left side of the visual touch screen.

(1) Program key

Mirror Image of Patterns

To sew or program the pattern as a mirror image, press the vertical mirror key or horizontal mirror key.

Mirror image icon appears on the screen and mirror image function is enabled.

Select the desired patterns to create the mirror image.

Press the vertical or horizontal mirror key again to cancel the mirror image function.

(2) Vertical mirror key

(3) Horizontal mirror key

(4) Vertical mirror icon

(5) Horizontal mirror icon

(6) Vertical and horizontal mirror icon

NOTE:

- Horizontal mirror image is available only for specific patterns. For pattern identification, these patterns are shaded in light gray on the stitch chart (Refer to pages 151-155).
- The vertical or horizontal mirror image key will gray out when the selected pattern is not suitable for the mirror image.

To view the entire pattern combination, press the cursor key to scroll over the pattern combination or press the preview key to show the entire pattern combination at a glance.

(7) Cursor keys

(8) Preview key

NOTE:

Presser foot pressure cannot be adjusted to the stitch patterns of a pattern combination individually. If you attempt to do so, only the last pattern's presser foot pressure settings are applied to all the programmed patterns.

Bridge Stitches

Bridge stitches are used for inserting straight stitches after a stitch pattern.

The number beside the stitch image on the straight stitch key indicates the stitch count of a programmable unit.

If you want more space between French knots (D6), for example, insert pattern BR5 after pattern D6.

Two counts of straight stitches are added to pattern D6.

NOTE:

Patterns BR5, BR6 and BR8 will inherit the stitch length and needle drop position of the previous pattern in the pattern combination.

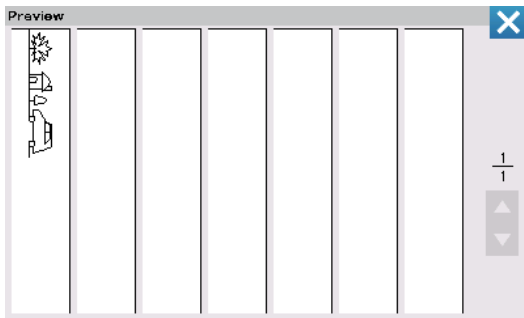
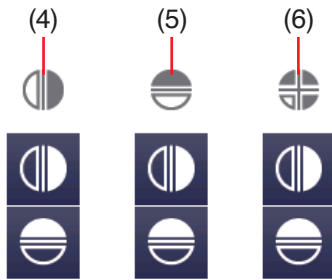
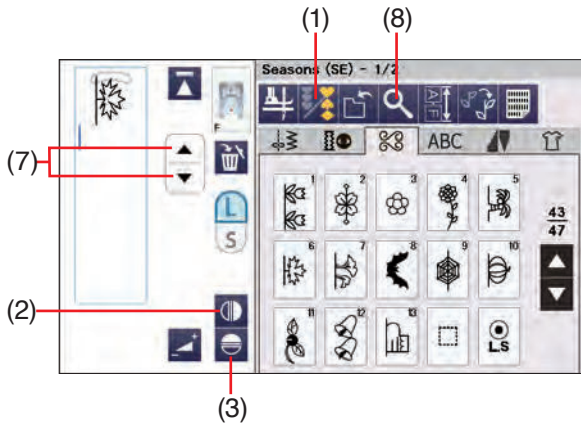

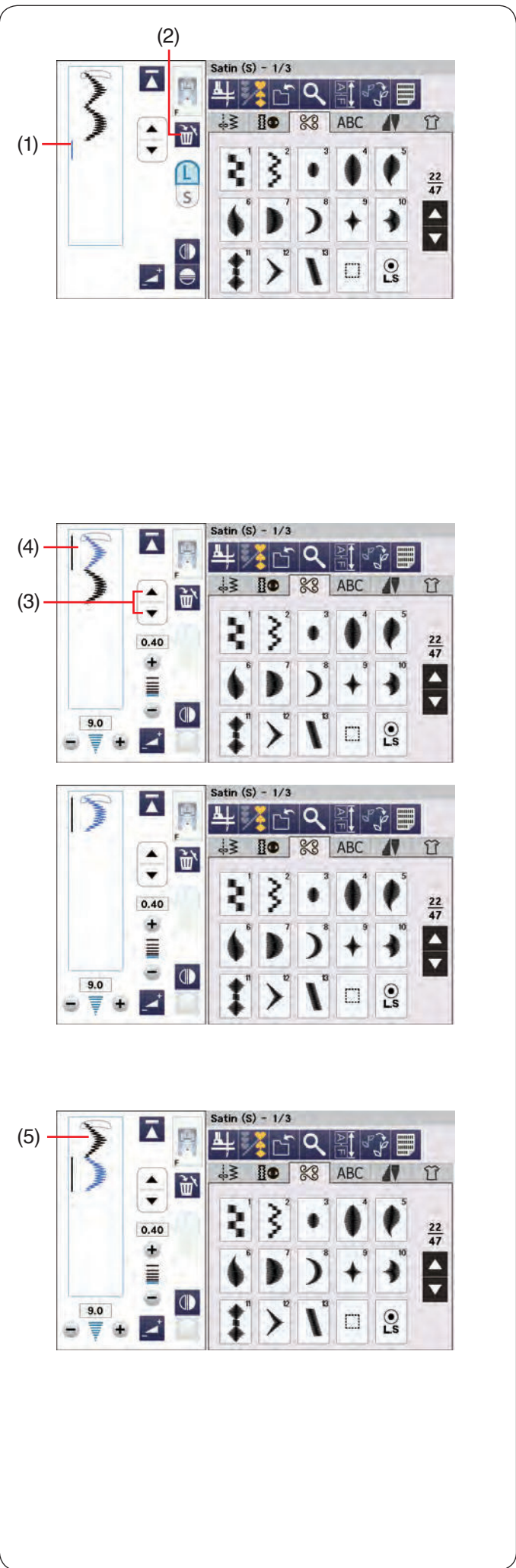

Editing a Pattern Combination

The programmed pattern (pattern combination) can be edited in the programming mode. You can insert, delete or flip the stitch pattern by selecting the stitch with the cursor. You can also adjust the stitch width and stitch length.

Deleting a Pattern

The pattern before the cursor or shown in blue is deleted by pressing the delete key.

- (1) Cursor
- (2) Delete key

To delete a pattern in the middle of a combination, press the cursor key to select the pattern you wish to delete.

The stitch image of the selected pattern turns blue. Press the delete key to delete the selected pattern.

- (3) Cursor keys
- (4) Selected pattern

Inserting a Pattern

Press the cursor keys to select the pattern next to where you wish to insert a pattern. Enter the desired pattern to insert it before the selected pattern.

- (5) Inserted pattern

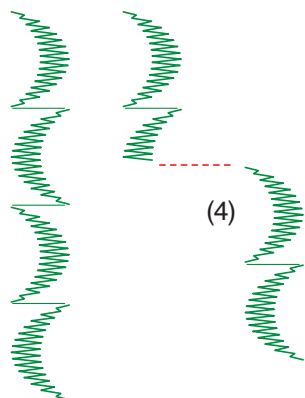
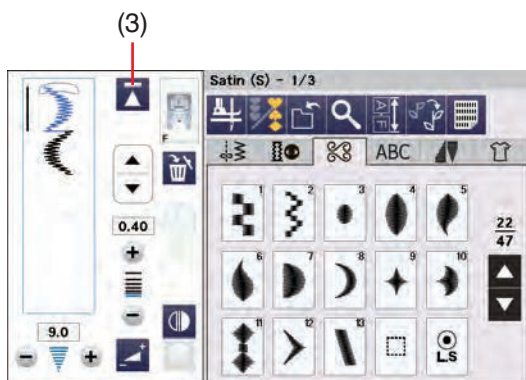
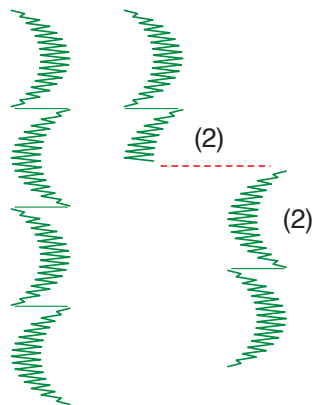
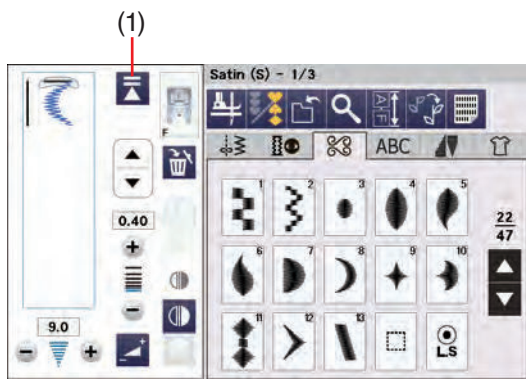

Startover Key

This is a 2-way function key to start sewing a pattern combination over from the beginning.

When you stop sewing a pattern combination, the startover key is activated.

Current pattern startover

If you wish to start sewing from the beginning of the current pattern, press the startover key once and start the machine. The key will change and show a triangle and double bar that means the machine will start over from the current pattern of the combination.

- (1) Startover key (current pattern of the combination)
- (2) Current pattern

NOTE:

When you stop sewing a pattern combination during the first pattern and press the startover key, the number of the bar above the triangle will not change because the pattern will be sewn from the first pattern.

First pattern startover

The key shows a triangle and single bar that means the machine will start over from the first pattern.

If you wish to start sewing from the beginning of the first pattern of the combination, press the startover key twice and start the machine.

- (3) Startover key (first pattern of the combination)
- (4) First pattern

NOTE:

If auto thread cutting is done, the machine will startover from the first pattern.

Checking Pattern Combination Length

You can check the total length of the pattern combination by pressing on the pattern combination length key.

- (1) Pattern combination length key

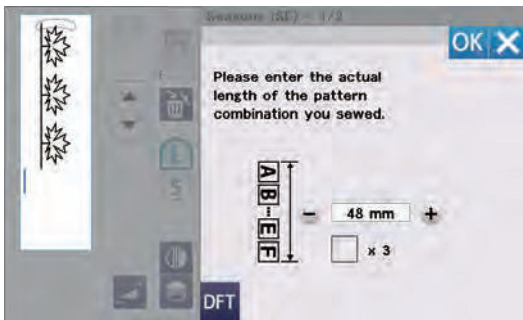
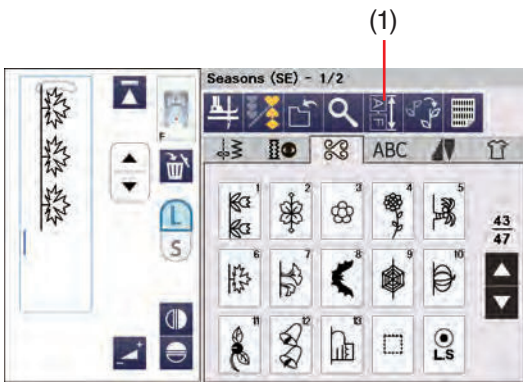

The readout of the total length is a theoretical value and the actual length may vary depending on sewing conditions.

For example, select pattern SE6 three times, and sew a pattern combination.

If the actual length differs considerably from the readout, measure the actual length and enter the nearest value by pressing the “+” or “-” key.

In this case, the theoretical value is 48 mm. However, if the actual length is 40 mm, enter 40 mm by pressing “-” key. Press the OK to register it.

- (2) Actual length

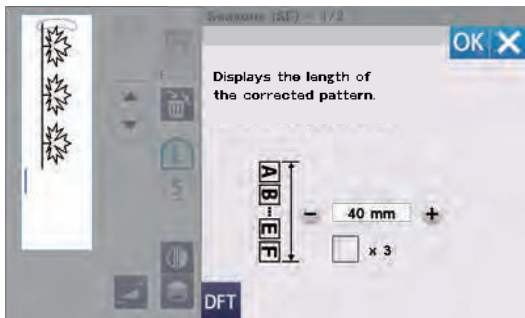
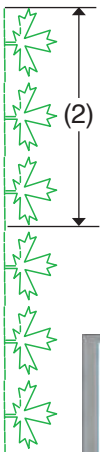

The readout is adjusted automatically when calculating the length of other pattern combinations.

The message “Displays the length of the corrected pattern.” appears to indicate that the displayed value is adjusted already.

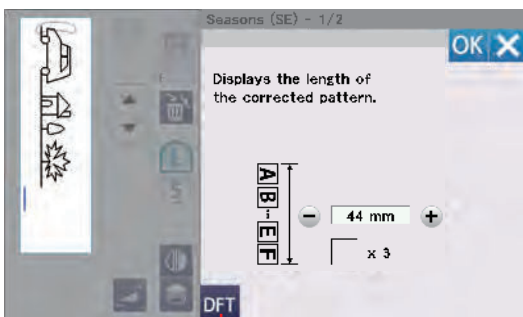

For example select patterns LS4, LS6 and SE6.

The theoretical value is 53 mm. However, the read out is calculated according to the measured actual length. In this case, the adjusted value is 44 mm.

Press the default key to clear the entered length.

- (3) Default key

Tapering

You can taper the beginning and end of the decorative stitch patterns to create tapered corners and points. Press the tapering tab to enter the tapering mode (refer to page 36).

(1) Tapering tab

NOTE:

- The tapering length varies depending on the stitch pattern and its tapering shape. Make a test stitch on an extra piece of the fabric to check the tapering length.
- If you stop the machine while sewing, and change the stitch width, needle drop position or stitch length, the machine will start tapered sewing from the beginning.

Stitch reference chart for tapering

Press the stitch reference key to show the stitch reference chart for the tapering.

- (2) Stitch reference key
 (3) Stitch reference chart for tapering
 (4) Page number

Preview

Press the tapering adjustment key to preview the selected tapering stitch.

The left column shows the start tapering pattern.

The center column shows the pattern body.

The right column shows the end tapering pattern.

- (5) Tapering adjustment key
 (6) Start tapering pattern
 (7) Pattern body
 (8) End tapering pattern

When the size of the tapering stitch is set, the number of the pattern body to be sewn appears above the window (refer to page 93).

- (9) Number of body patterns

Tapered Stitch Sample 1

Example: To sew the tapered stitch pattern #10

Select the stitch pattern #10.

Start the machine. The machine sews the start tapering pattern and pattern body.

Sew to the required length, then press the auto-lock button. The machine sews the end tapering pattern and stops.

- (10) Auto-lock button
 (11) Required length
 (12) Start tapering pattern
 (13) End tapering pattern

To sew the same sized tapered pattern

When finished sewing, a confirmation message will appear. The number shown indicates the number of the body patterns.

- (14) Number of body patterns

Press OK and simply start the machine to sew another tapered pattern of the same size.

To sew the same tapered pattern in a different size, press the X key.

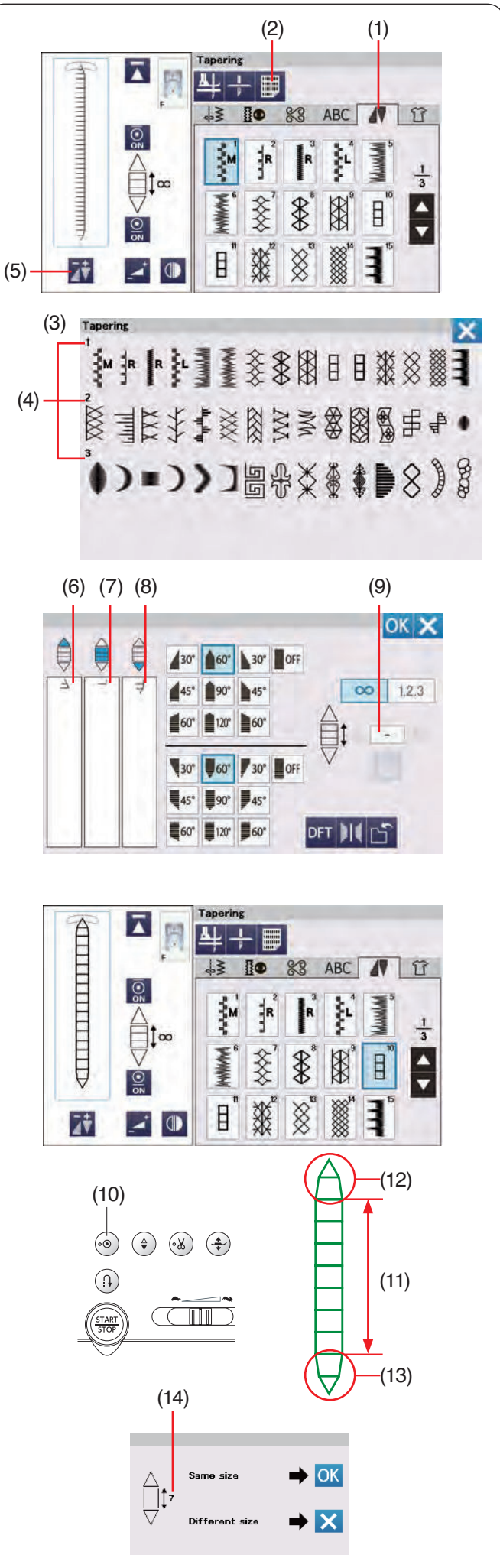

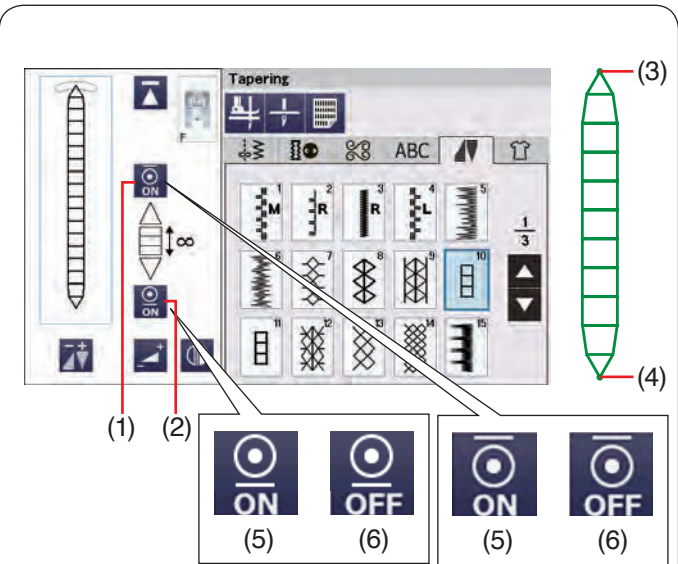

Auto-lock Stitch Function

The machine sews auto-lock stitch at the beginning and end of the sewing with the default settings. However, you can turn on or off the auto-lock stitches by pressing the corresponding auto-lock keys on the visual touch screen.

- (1) Initial lock stitch key
- (2) End lock stitch key
- (3) Initial lock stitch
- (4) End lock stitch
- (5) Lock stitch key (ON)
- (6) Lock stitch key (OFF)

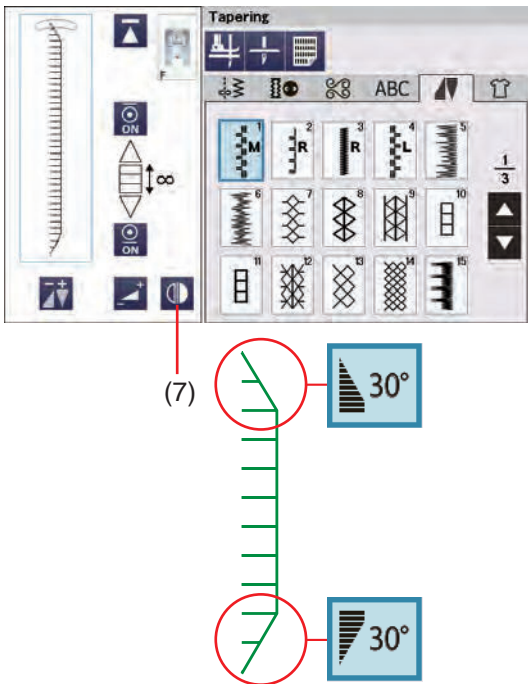

Flipping the Tapered Pattern 1

Press the static flip key to flip the tapered pattern vertically without flipping its start and end tapering degree angle.

- (7) Static flip key

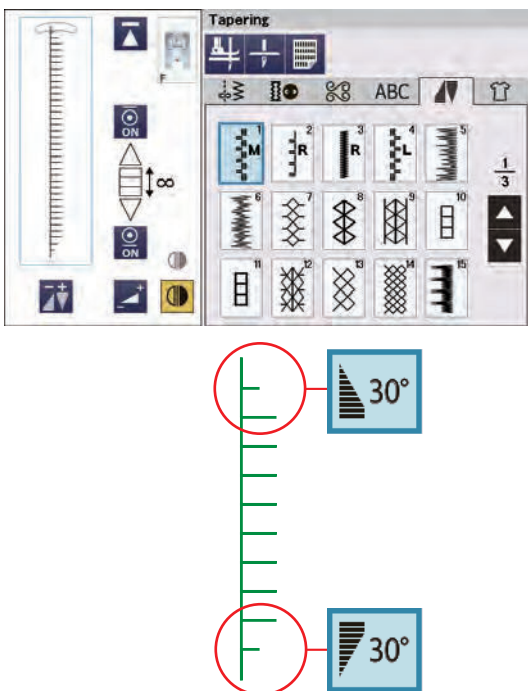

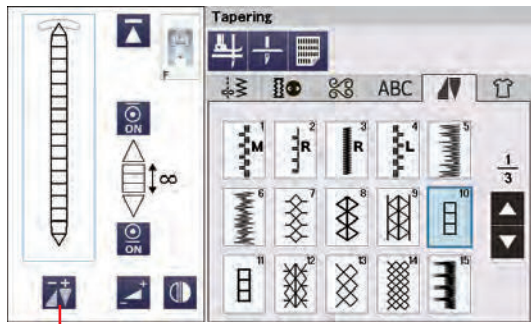

(1)

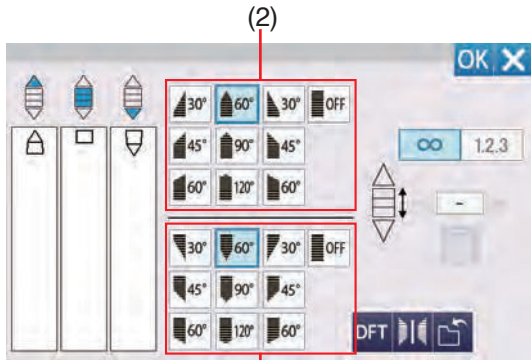

(2)

(3)



(4)



(5)

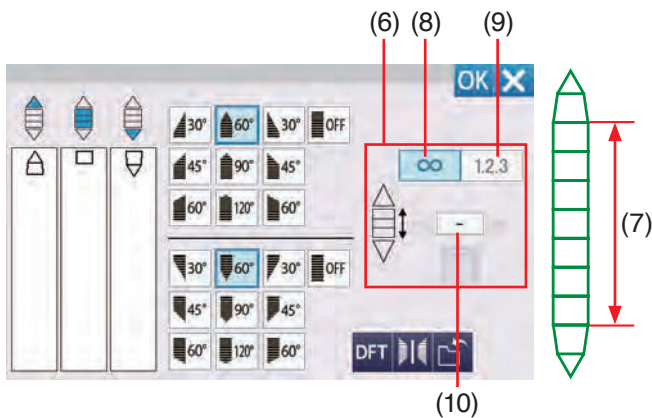

(6) (8)

(9)

(10)

(7)

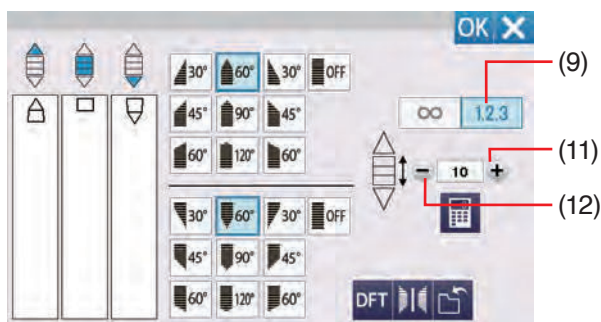

(9)

(11)

(12)

Adjustment of Tapered Stitches

You can adjust the shape of the tapered stitch pattern. Press the tapering adjustment key. The tapering adjustment window will open.

- (1) Tapering adjustment key

Tapering shape

Select the shape of the tapering for the beginning and the end of the stitch patterns by pressing the tapering shape keys.

The keys on the top are for start tapering pattern.

The keys on the bottom are for end tapering pattern.

- (2) Tapering shape keys (for start tapering pattern)
- (3) Tapering shape keys (for end tapering pattern)
- (4) Start tapering pattern
- (5) End tapering pattern

The numbers in the tapering shape keys indicate the degree of tapering. You can apply the tapering alignment from left, center, right or off. The start and end of the stitch patterns can be aligned separately.

Pattern body length

The keys on the right are for pattern body length.

The machine sews the pattern body as long as the auto-lock key is pressed when the free length key is turned on. However, you can set the number of the pattern body to be sewn by pressing the pattern length key.

- (6) Keys on the right
- (7) Pattern body
- (8) Free length key
- (9) Pattern length key
- (10) Number of the body patterns

Press the pattern length key.

Press the "+" or "-" key to set the number to repeat the pattern body.

- (9) Pattern length key
- (11) "+" key
- (12) "-" key

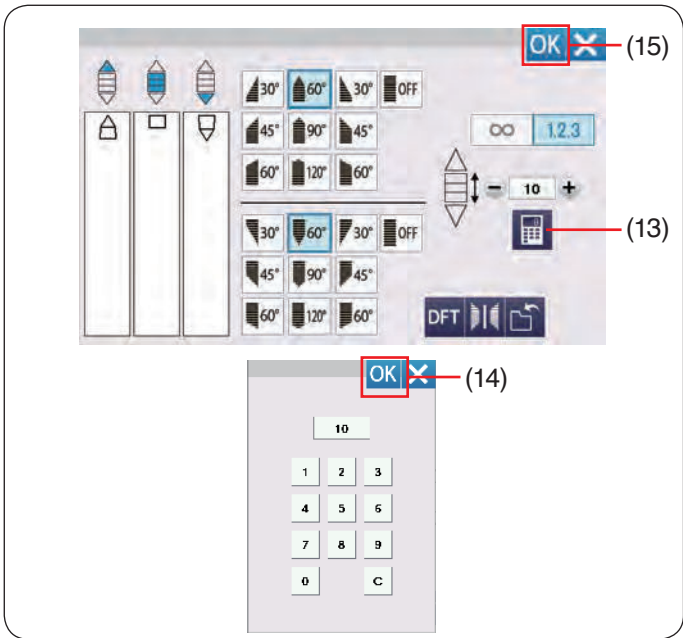

You can also set the number to repeat the pattern body by pressing the numeric pad key.

Press the numeric pad key and the numeric keypad window will open.

Enter the desired pattern length and press the OK key.

(13) Numeric pad key

(14) OK key

After the shape of the tapered stitch pattern is selected, press the OK key to apply the tapered stitch pattern.

(15) OK key

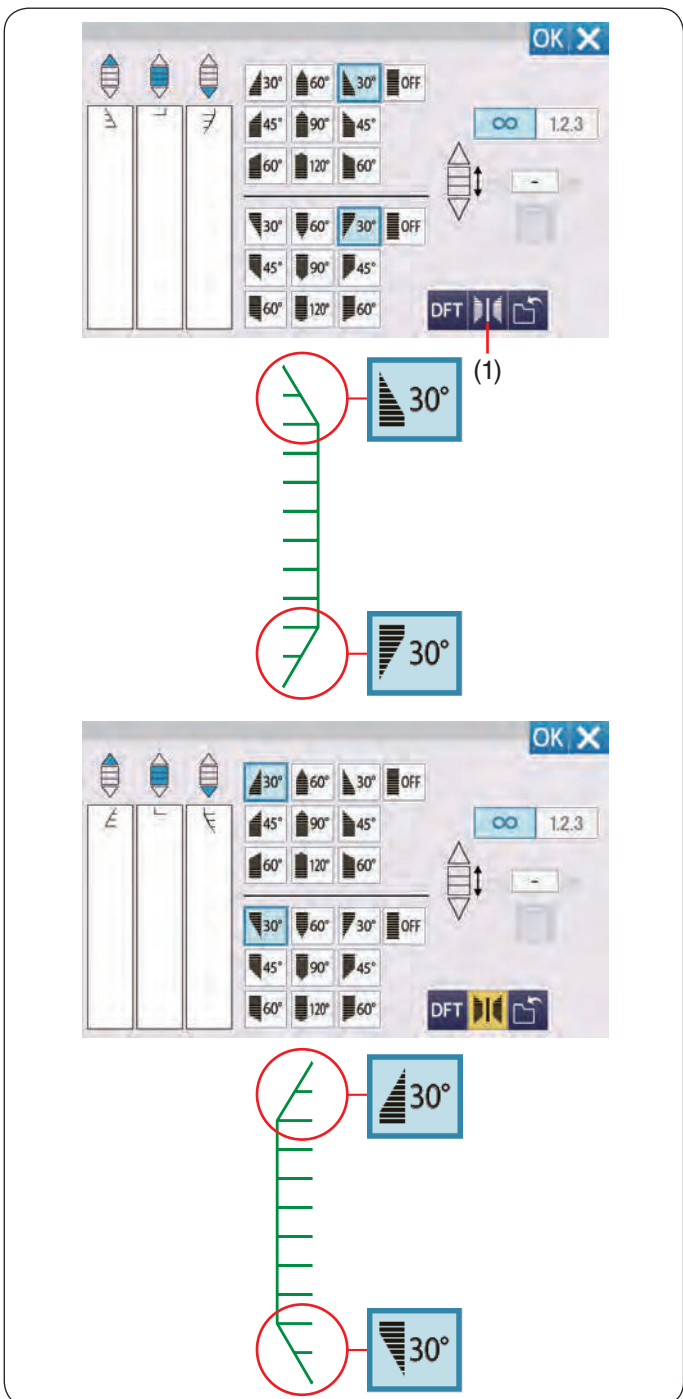

Flipping the Tapered Pattern 2

Press the mirror image key to flip the tapered pattern vertically.

(1) Mirror image key

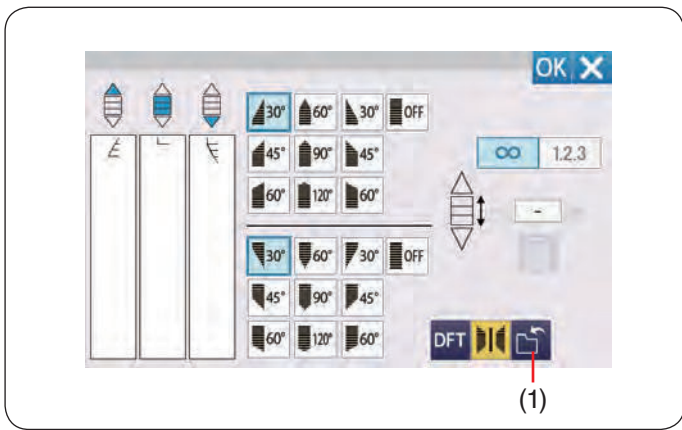

Saving tapered stitches

The customized tapered patterns can be saved as a file in the machine's internal memory or a USB flash drive.

Press the save file key after customizing a tapered stitch. The tapered stitch file is saved as a *.JCS file. To save or open the file refer to pages 101-102.

- (1) Save file key

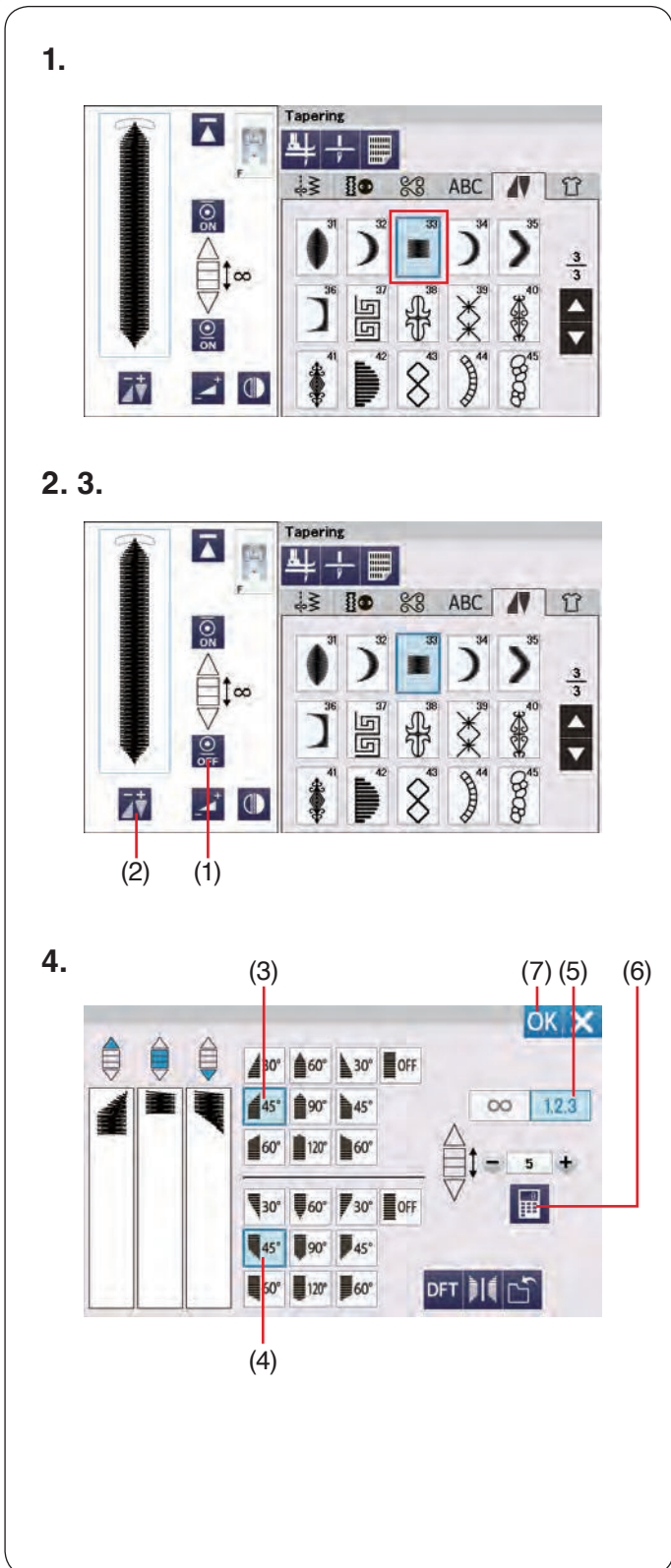

Tapered Stitch Sample 2

Example: To create a corner frame with the tapered stitch pattern #33

1. Select the stitch pattern #33.
2. Press the end lock stitch key to turn off the end lock stitch.
 - (1) End lock stitch key
3. Press the tapering adjustment key.
 - (2) Tapering adjustment key
4. Press the tapering shape key (for start tapering pattern).
 Press the tapering shape key (for end tapering pattern).
 Press the pattern length key.
 Press the "+" key 4 times, or press the numeric pad key and enter "5" (refer to page 94).
 Press the OK key.
 - (3) Tapering shape key (for start tapering pattern)
 - (4) Tapering shape key (for end tapering pattern)
 - (5) Pattern length key
 - (6) Numeric pad key
 - (7) OK key

5.

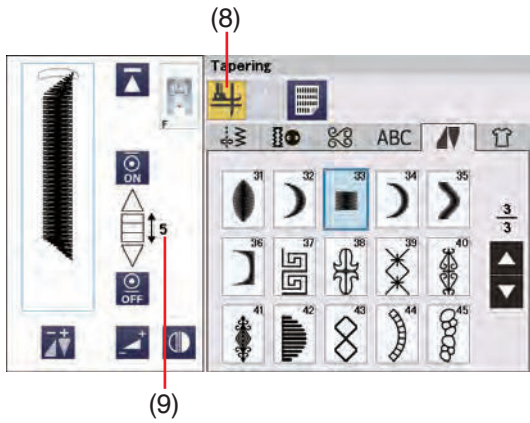

5. Press the foot-up key.
You can check the number of body patterns on the icon.

- (8) Foot-up key
- (9) Number of the body pattern

6.



6. Lower the needle into the fabric at the point where you want to start sewing.

Start sewing. Sew until the machine stops.
The machine stops and the presser foot rises automatically.

7.

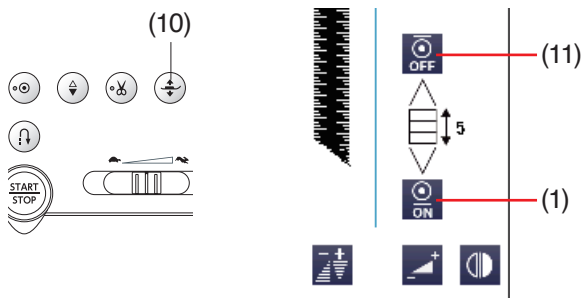

7. Pivot the fabric 90 degrees.

Press the presser foot lifter button to lower the presser foot.

Press the initial and end lock keys.

Be sure that the initial lock key is turned off, and the end lock key is turned on.

Start sewing in the new direction.

- (10) Presser foot lifter button
- (11) Initial lock stitch key
- (1) End lock stitch key

8.

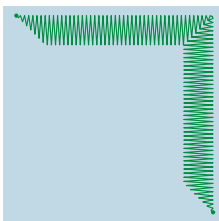

8. The machine automatically stops at the end of the corner with the lock stitch.

MONOGRAMMING

You can program letters and symbol designs for monogramming.

Press the monogramming tab and the font selection window will open.

(1) Monogramming tab

You can select one of 6 fonts.

Select the desired font by pressing the corresponding key.

(2) Block key

(3) Script key

(4) Broadway key

(5) Block (9 mm) key

(6) Cyrillic key

(7) Symbol key

The monogram mode window will open.

NOTE:

The height of Block (9 mm) is approximately 9 mm.

Function Keys

(8) Save file key

Press this key to save the monogram as a data file.

(9) Preview key

Press this key to view the entire monogram.

(10) Pattern combination length key

Press this key to check the total length of the entire monogram.

(11) Delete key

Press this key to delete the selected characters.

(12) Cursor keys

Press the cursor key to move the cursor up or down.

(13) Letter size key

Press this key to select the full size (L) or small size (S).

(14) Letter case key

Press this key to select the upper case or lower case.

(15) Character type key

Press this key to select the character type among alphabets, numerals, symbols and European characters.

NOTE:

Numbers, symbols and European letters are available on pages 2/5 through 5/5.

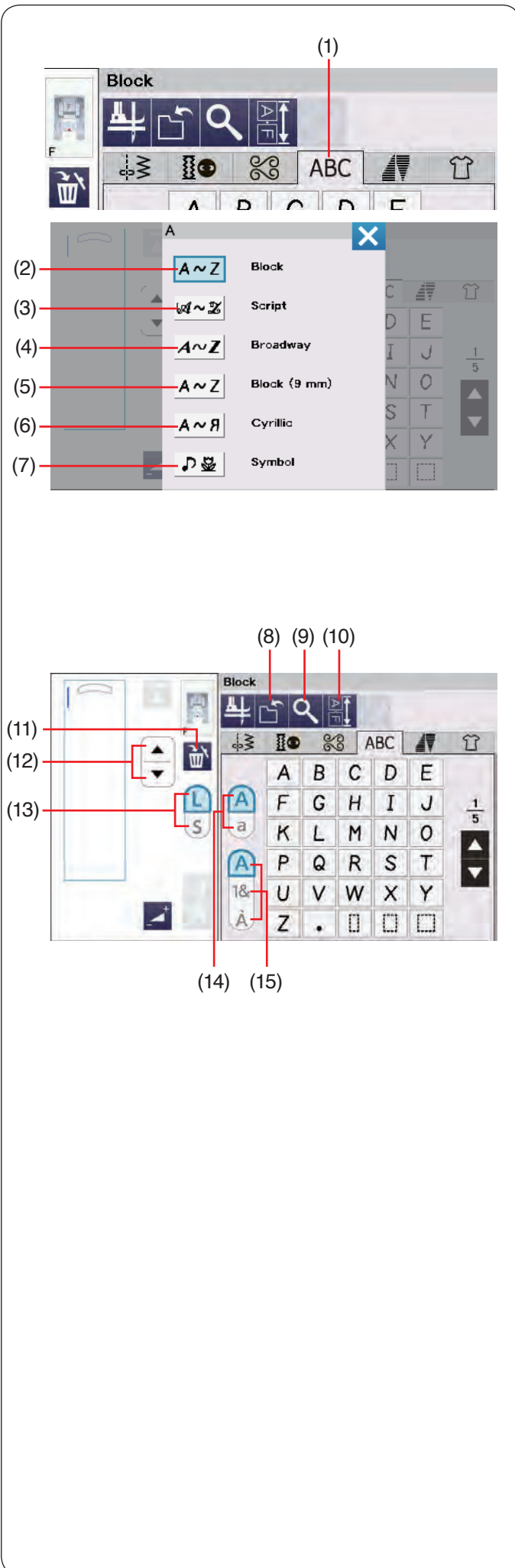

Manual Thread Tension

This machine is equipped with automatic thread tension control. However, you may need to manually adjust the tension balance depending on the sewing conditions.

To adjust the thread tension, press the adjust key  to show the option.

Individual Thread Tension Adjustment

To apply the thread tension adjustment to each letter individually, select the letter by moving the cursor with cursor keys.

- (1) Cursor
- (2) Cursor keys

Press the “+” or “-” key to adjust the thread tension of the selected letter. The adjusted thread tension is applied to the selected letter.

- (3) Thread tension adjustment

Unified Thread Tension Adjustment

To apply the thread tension adjustment to all letters together, you do not need to select the letters.

Press the unified thread tension key.

- (4) Unified thread tension key

Press the “+” or “-” key to adjust the thread tension. The adjusted thread tension is applied to all entered letters.

When unified thread tension control is applied, the unified thread tension key turns to yellow.

Press the unified thread tension key again to deactivate the unified thread tension adjustment.

NOTE:

Unified thread tension adjustment cannot be applied to Symbol characters or decorative stitches.

Spacing

To enter a space in monogramming, press one of the three space keys on the lower right corner of the monogram selection.

- (1) Space keys
- (2) Small-size space
- (3) Medium-size space
- (4) Large-size space

Reducing the Size of Letters

To reduce the height of a character to approximately 2/3 of full size (L), select the character and press the letter size key.

- (1) Letter size key

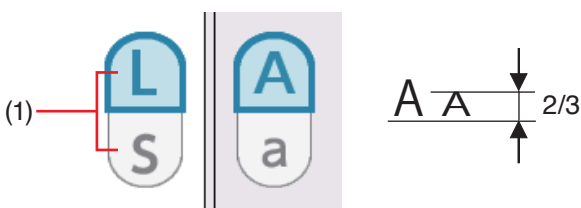
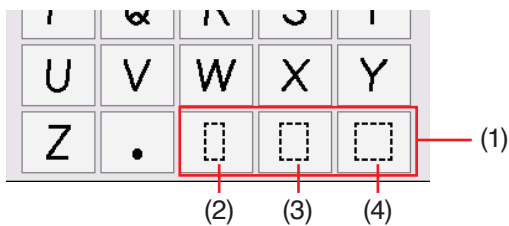
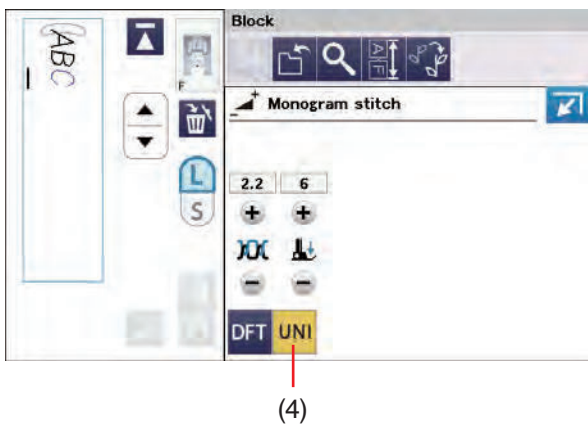
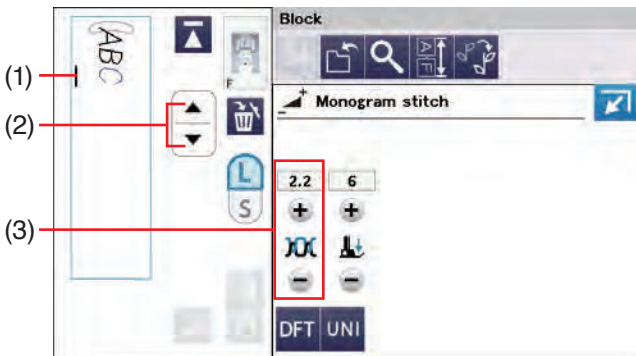

Programming a Monogram

Simply enter the characters by pressing the corresponding keys to program a monogram.

NOTE:

Use a blue tip needle for sewing a monogram.
Apply a sheet of stabilizer to fine fabrics or stretch fabrics.
Test sew to check the sewing results.

Example 1: “Quilt” in Block font

Press the monogramming tab and select Block font.
Enter “Q”.

Press the letter case key to select lower case.

- (1) Monogramming tab
- (2) Letter case key

Enter “u”, “i”, “l” and “t”.

Start sewing. Sew until the machine stops.

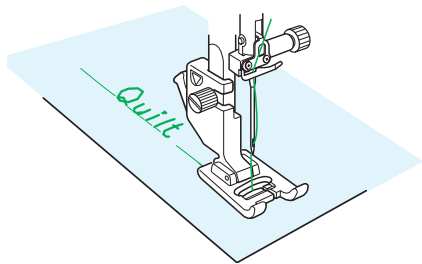
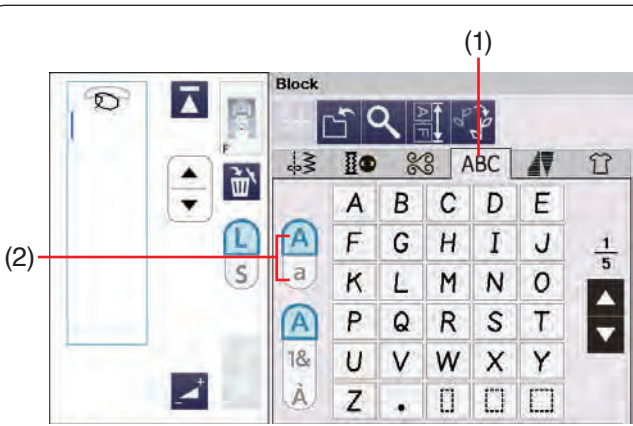

Example 2: “♥Café” in Broadway font

Press the monogramming tab and select Symbol.

Enter a hollow heart.

Press the monogramming tab and select Broadway font.

Enter “C”.

(1) Monogramming tab

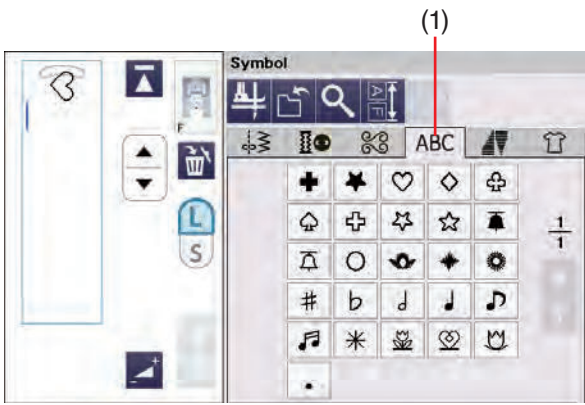

Press the letter case key and select lower case letters.
Enter “a” and “f”.

(2) Letter case key



Press the character type key to go to the page 4 of 5.
Enter “é”.

(3) Character type key

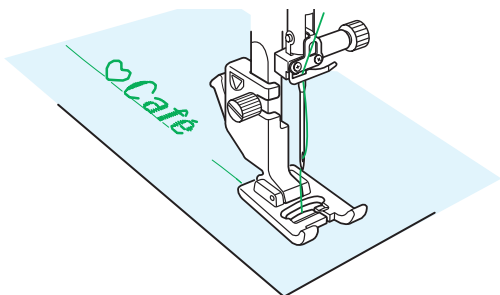

Start sewing. Sew until the machine stops.

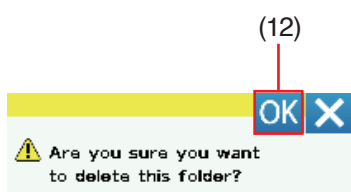
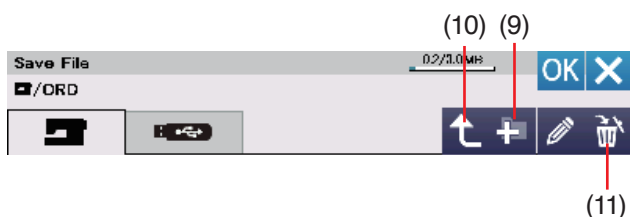
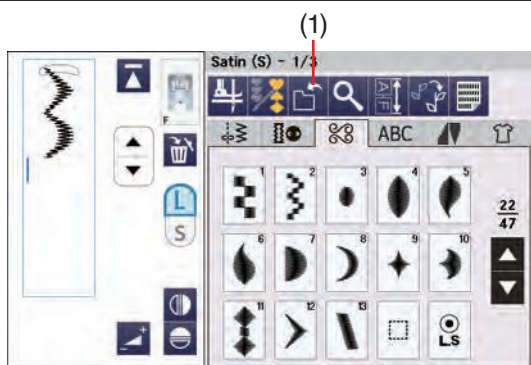

Saving a Pattern Combination

The pattern combination and monogram can be saved as a file in the machine's internal memory or a USB flash drive. The machine has a USB port for USB flash drives.

Press the save file key after programming a pattern combination, and the save file window will open.

(1) Save file key

Select the location to where you wish to save the pattern combination.

The "Ordf" folder is shown.

The file name is assigned automatically starting from C_001.....in order.

Select the "Ordf" folder.

Press the OK key to save the file under the assigned name.

(2) File name

If you wish to assign a unique name to the file, press the rename key and the keyboard window will open.

(3) Rename key

If you wish to use QWERTY layout keyboard, press the keyboard tab.

Press the upper or lower case key to select letter case.

(4) ABC tab

(5) Keyboard tab

(6) Upper case key

(7) Lower case key

Enter a new name and press the OK key to change the file name.

Press the OK key and the file is saved under the new name.

NOTE:

- The files and folders are displayed on different pages. Press page keys to switch the window.
(8) Page keys
- This model supports FAT16 and FAT32 formats only. If the USB flash drive is not read, check its format (refer to pages 149-150).
- Do not use a USB card reader and USB hub.

Creating a New Folder

Select a location for a new folder and press the new folder key. The keyboard window will open.

Enter a folder name and press the OK key.

The new folder is created under the assigned name.

(9) New folder key

NOTE:

Press the parent directory key to move to the parent directory and display the folder.

(10) Parent directory key

Deleting a File or Folder

Press the delete key and select the file or folder to delete. A confirmation message appears.

Press the OK key to delete the file or folder.

(11) Delete key

(12) OK key

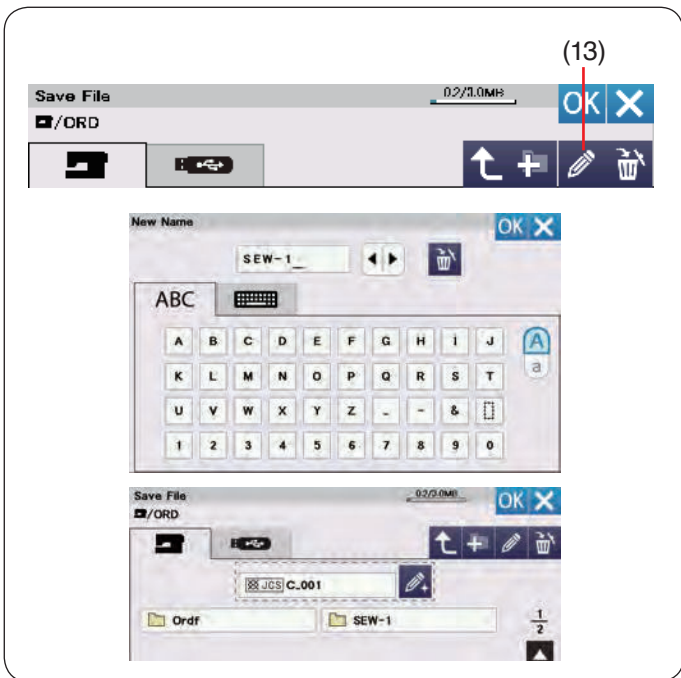

Changing a File Name or Folder Name

Press the rename key and select the file or folder of which you wish to change its name. The keyboard window will open.

Enter the new name and press the OK key. The name of the file or folder will change.

(13) Rename key

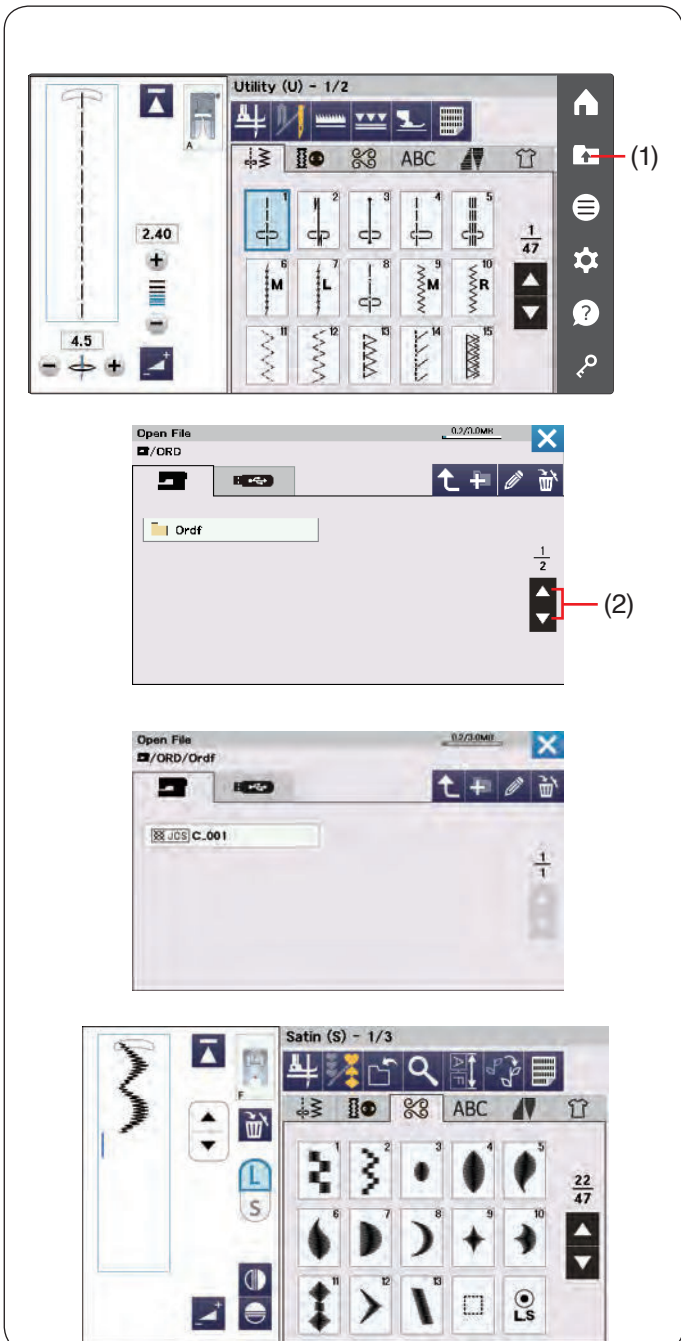

Opening a Pattern Combination

You can open the pattern combination, monogram and tapered stitch saved in the machine's internal memory or a USB flash drive.

Press the open file key and the open file window will open.

(1) Open file key

Select the memory location; either the machine's internal memory or a USB flash drive.

The "Ordf" folder will appear.

NOTE:

- If you created any folders before, those folders will also appear.
- If you cannot find the desired folder or the file in the page, press the next or previous page key to display the other pages.

(2) Page keys

Select the desired folder and the file list will appear.

Select the desired file.

The screen will return to the ordinary sewing window showing the saved pattern combination or monogram.

HAND STITCH STYLE

Hand Stitch Style

You can create your own seams as if sewn by hands by giving subtle differences to sewing patterns.

This can be used for decorative patterns of children's clothing or small articles other than crazy quilts.

Use thick thread (#30) for more effective sewing results.

The hand stitch style can be used in the programming mode (refer to page 87).

NOTE:

The hand stitch style cannot be applied to the Bridge stitches (BR1-8), Mirage stitches (M1-7) and the monogram fonts except the followings.

The hand stitch style can be applied to the stitch patterns, the monogram fonts of full sized block letters, and symbols/numbers of cyrillic letters.

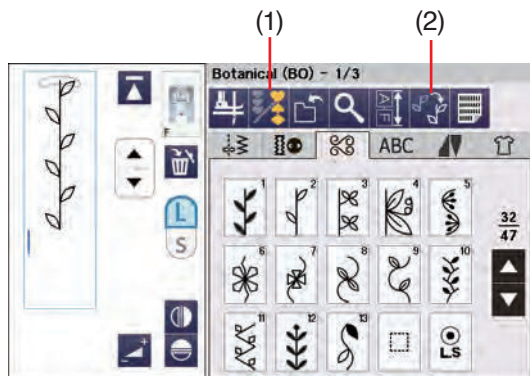
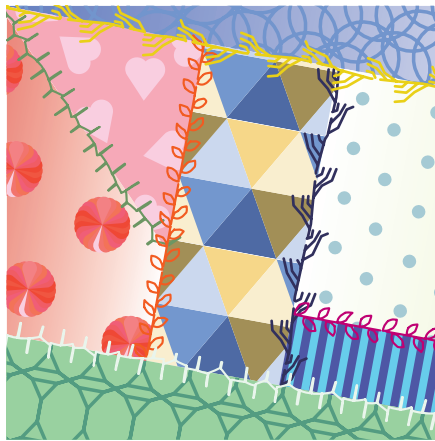

You can enjoy delightful sewing results every time you change the patterns.

By combining those patterns with subtle differences, you can create unique feeling patterns unlike regular ones.

Shapes of patterns may be distorted depending on types, thickness and the speed of sewing of the fabric.

Always test sew on an extra piece of the fabric that you wish to use.

To sew:

1. Press the program key.
Select the desired stitch patterns.
(1) Program key
2. Press the hand stitch style key.
Hand stitch style settings window will open.
(2) Hand stitch style key
3. To select the pattern, press the cursor key to move the cursor up or down.
(3) Cursor keys

To select all the patterns, press the ALL key.
(4) ALL key

4. To adjust variation strength of the selected pattern, press the "+" or "-" key.
(5) Variation strength adjustment

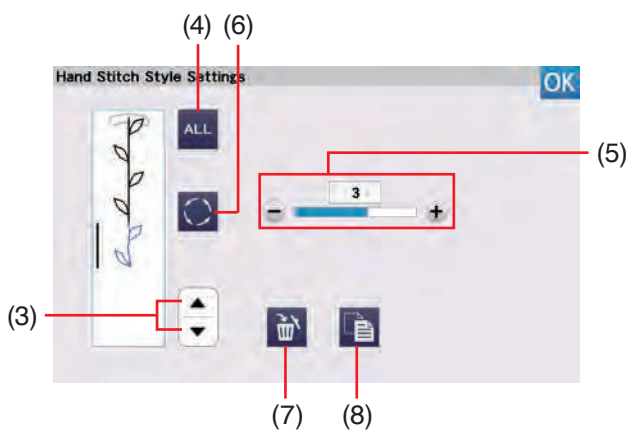

NOTE:

The adjustable range of variation strength are OFF (0) to 5.

5. You can change variation style. To change the variation style, press the variation style key.
(6) Variation style key
You cannot choose the previous variation style after a change.
6. You can delete or copy selected pattern individually. To delete the selected pattern, press the delete key. To copy the selected pattern, press the copy key.
(7) Delete key
(8) Copy key

Check the sewing image. Test sew on an extra piece of the fabric that you wish to use.

Save your favorite variation style with the save file key (refer to page 101).

NOTE:

The variation style will be changed when you change the elongation ratio of satin stitches or use the horizontal mirror image key.

SEWING APPLICATION

Variety of Sewing Applications

Sewing application is a unique feature that provides you with useful sewing applications.

Press the sewing application tab and the sewing application menu will open (refer to page 35).

Press one of the tabs to select the category.

- (1) Sewing tab
- (2) Quilt tab

The sewing applications using optional presser feet can be selected by pressing the optional foot tab.

Refer to optional feet instructions for usage details.

- (3) Optional foot tab

Sewing

In the Sewing category of the sewing application provides you with 22 useful sewing applications.

The 22 sewing applications are as follows:

- (1) Seaming Woven
- (2) Seaming Stretch/Knit
- (3) Curve
- (4) Topstitching
- (5) Rolled Hem
- (6) Overedge Woven
- (7) Overedge Stretch/Knit
- (8) Overedge Heavy
- (9) Blind Hem
- (10) Shell Tuck
- (11) Lapped Zipper
- (12) Invisible Zipper/CONCEAL® Zipper*
- (13) Pouch Zipper
- (14) Gathering
- (15) Easestitching
- (16) Basting
- (17) Buttonhole
- (18) Button
- (19) Tacking
- (20) Eyelet
- (21) Smocking
- (22) Fagoting

* "CONCEAL" is a registered trademark of YKK Corporation.

Quilt

In this category, 10 types of useful stitches for quilting are available.

Press the quilt tab and the quilt sewing application menu will open.

The 10 quilt sewing applications are as follows:

- (1) Patchwork Piecing
- (2) Free Motion
- (3) Ruler Work
- (4) Variable ZZ
- (5) Applique
- (6) Straight Stitch
- (7) Decorative Quilt Stitch
- (8) Clasp Stitch
- (9) Sashiko
- (10) Hand-Look QU

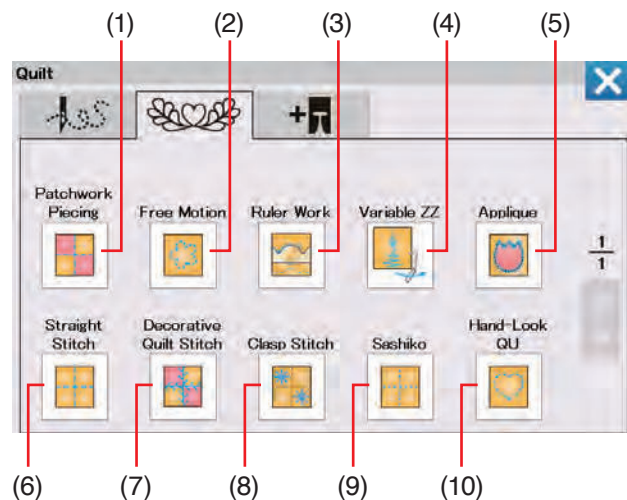
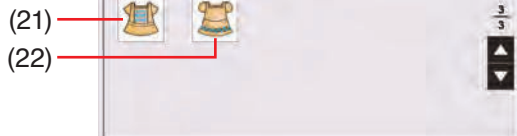
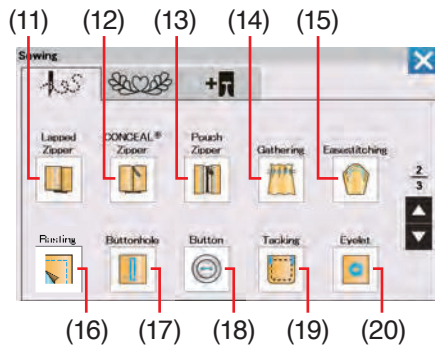
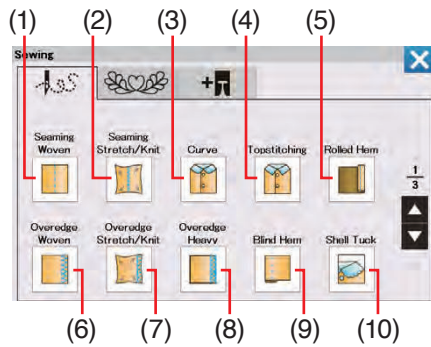
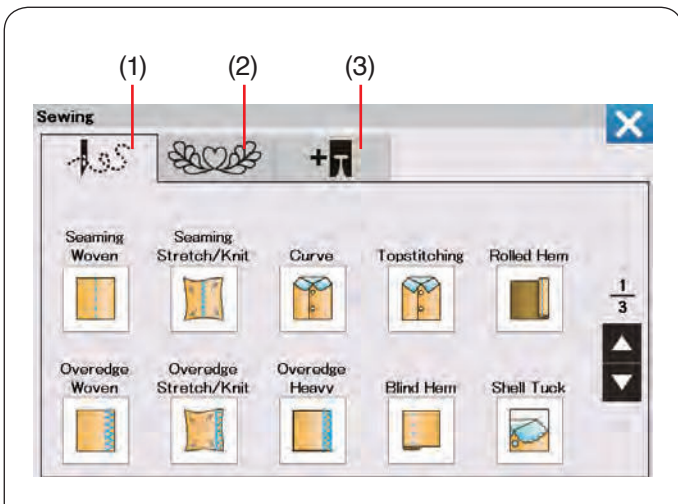

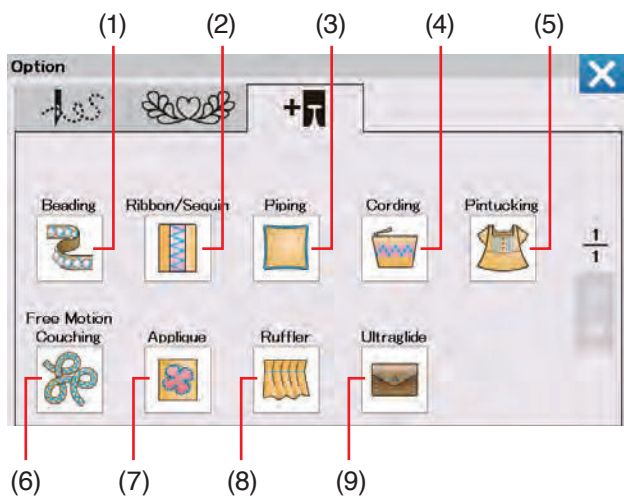

Optional Sewing Application

The option category of the sewing application provides you with 9 useful sewing applications.

Press the optional foot tab and the optional sewing application menu will open.

The 9 optional sewing applications are as follows:

- (1) Beading
- (2) Ribbon/Sequin
- (3) Piping
- (4) Cording
- (5) Pintucking
- (6) Free Motion Couching
- (7) Applique
- (8) Ruffler
- (9) Ultragliding

Refer to the instruction on an optional foot for sewing.

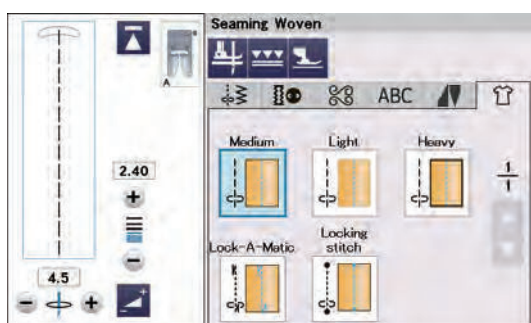

Sewing

Seaming Woven

Straight stitches for seaming regular woven fabrics.

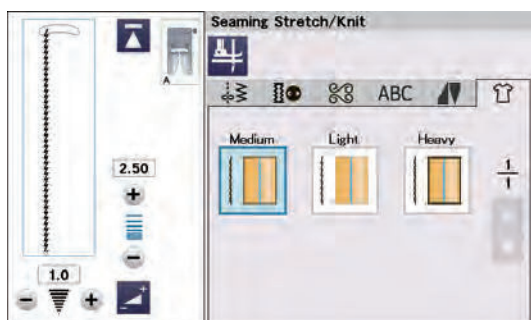

Seaming Stretch/Knit

Narrow stretch stitches for seaming stretch or knit fabrics.

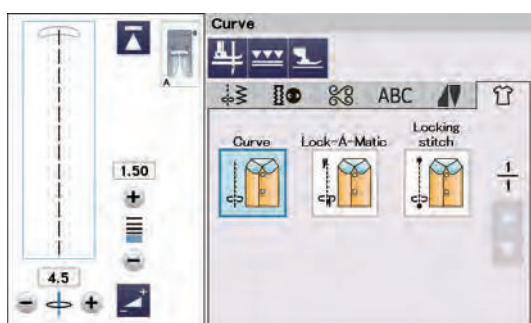

Curve

Short straight stitches for seaming curved lines.

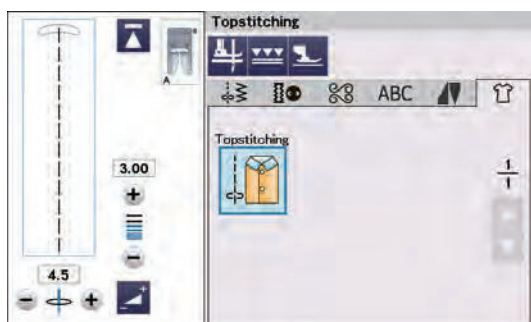

Topstitching

Long straight stitches for topstitching with thick threads.

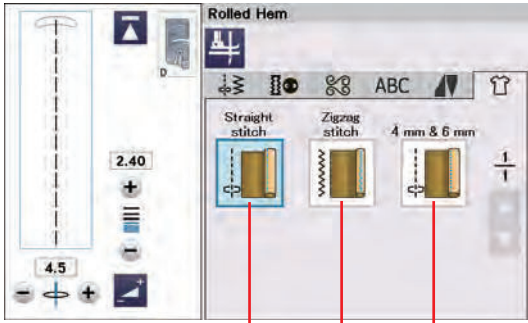

(1) (2) (3)

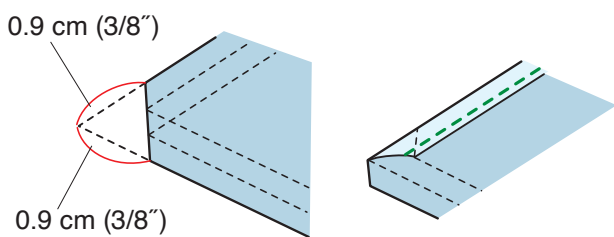
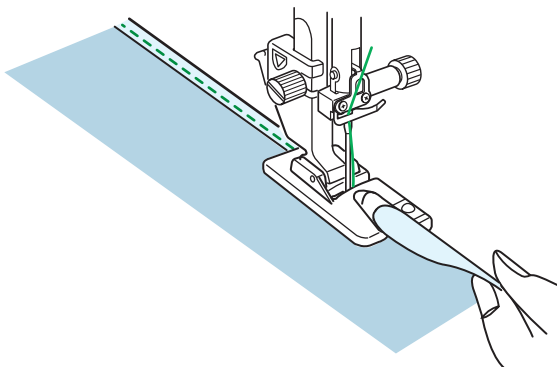
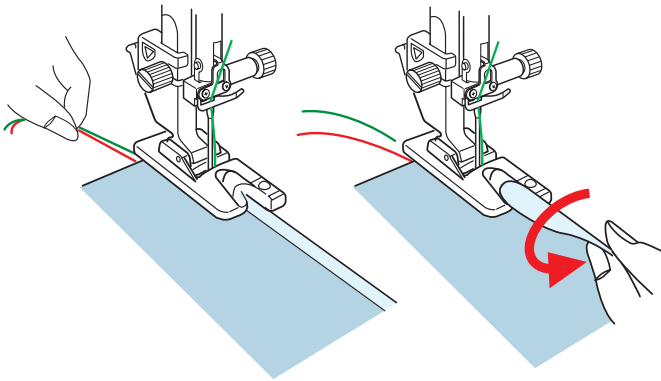
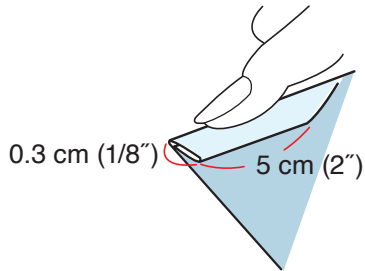

Rolled Hem

- (1) Straight stitch
Rolled hemming with straight stitch
- (2) Zigzag stitch
Rolled hemming with narrow zigzag stitch
- (3) 4 mm & 6 mm
Rolled hemming using optional rolled hemming feet D1 and D2

To sew:

Attach rolled hem foot D.

Fold the fabric edge twice to form a hem, 0.3 cm (1/8") wide and 5 cm (2") long then press.

Place the fabric aligning the hem edge with the guide of the foot. Turn the handwheel to lower the needle to the starting point.

Lower the foot and sew several stitches slowly while pulling on the threads to assist feeding the fabric.

Stop the machine and lower the needle into the fabric.

Raise the foot and insert the folded portion of the fabric into the curl of the foot.

Lower the foot and sew while lifting the edge of the fabric to keep it feeding into the curl smoothly and evenly.

NOTE:

Trim the corners 0.9 cm (3/8") to reduce bulk.

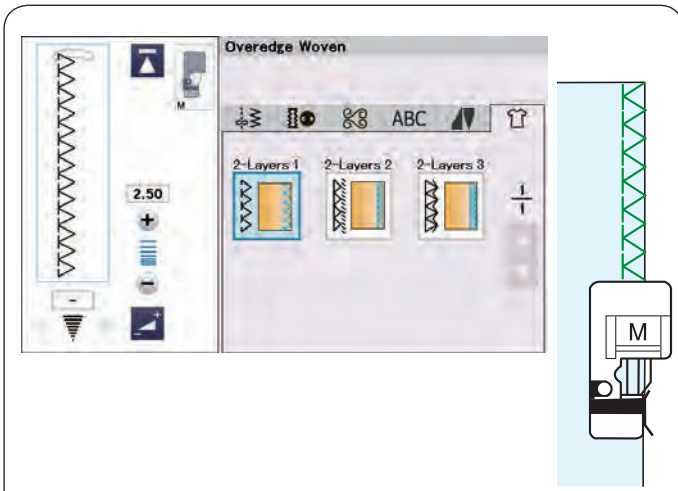

Overedge Woven

Overcasting stitch for 2 layers of regular woven fabrics.

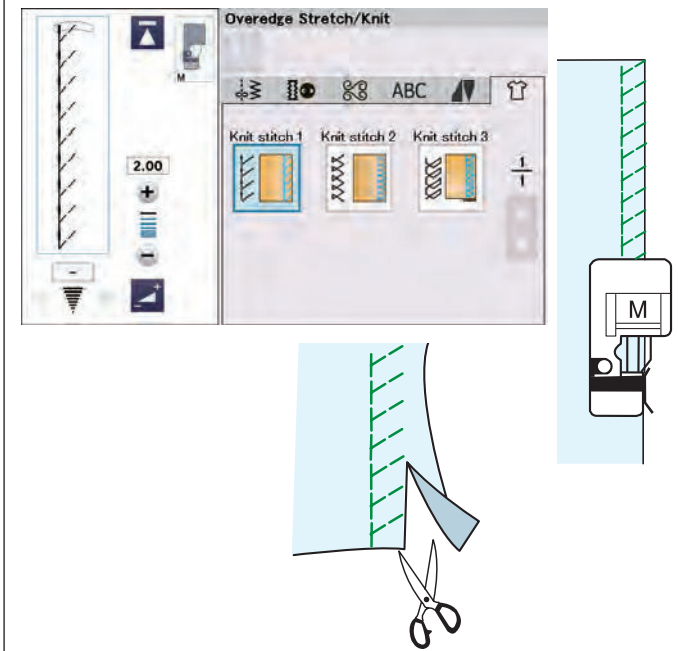

Overedge Stretch/Knit

Knit stitch for finishing raw edges of stretch or knit fabrics.

For better results, use the zigzag foot A and sew leaving an adequate seam allowance.

After sewing, trim the seam allowance close to the stitches (refer to page 47).

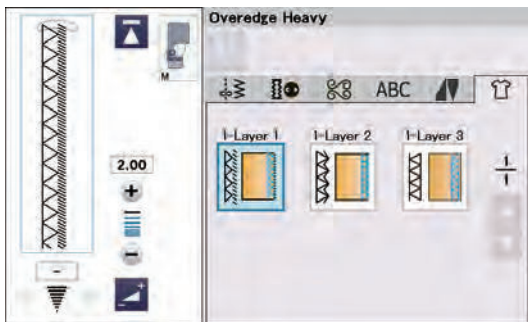

Overedge Heavy

Double overedge stitch for preventing raw edges of linens and gabardines from ravelling.

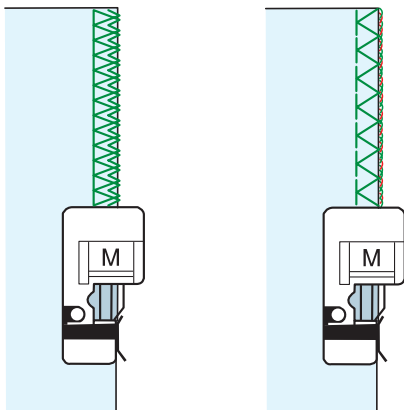

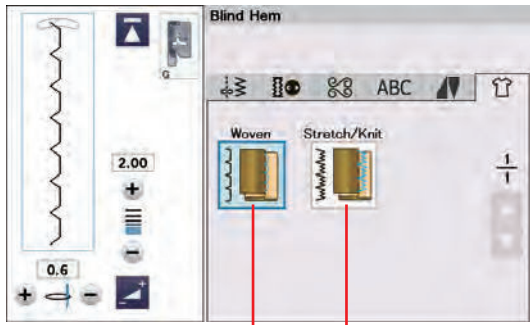

(1) (2)

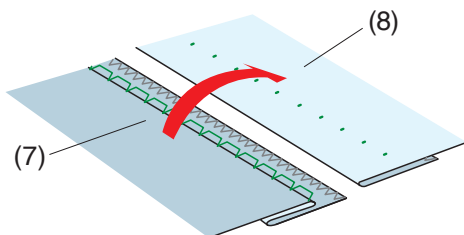
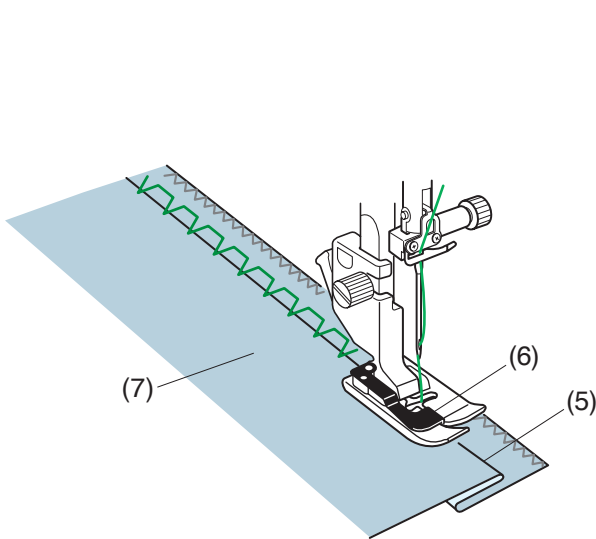
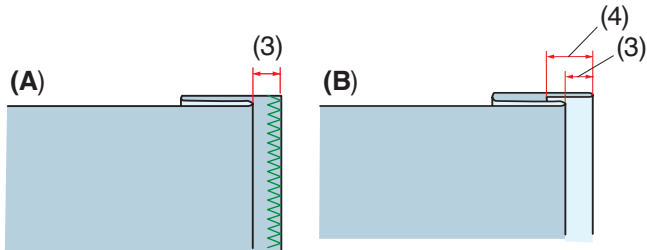

Blind Hem

The following 2 options are available.

(1) Woven

For blind hemming regular woven fabric.

(2) Stretch/Knit

For blind hemming stretch or knit fabric.

To sew:

Attach blind hemming foot G.

Fold the fabric to form a hem leaving a 0.5 cm (1/4") allowance as shown.

(3) 0.5 cm (1/4")

(A) Medium to heavy fabrics: The raw edge should be overcasted.

(B) Fine fabrics: Fold the raw edge 1 cm (3/8").

(4) 1 cm (3/8")

Position the fabric so that the fold comes to the left side of the guide on the foot. Lower the presser foot.

The needle should just pierce the folded edge when it comes over to the left side.

Adjust the position of the needle drop if necessary.

Sew guiding the fold along the guide.

(5) Fold

(6) Guide

(7) Wrong side of the fabric

After sewing is finished, open the fabric flat.

The seam on the right side of the fabric is almost invisible.

(7) Wrong side of the fabric

(8) Right side of the fabric

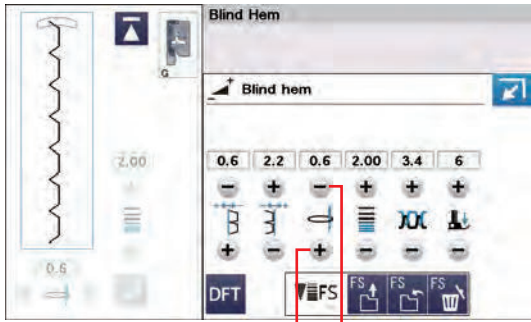

(1) (2)

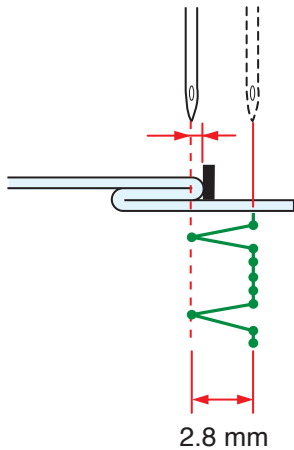

2.8 mm

Adjusting the needle drop position

Press the “+” key to expand the manual setting window.

Press the “+” key to move the needle drop positions to the left.

Press the “-” key to move the needle drop positions to the right.

- (1) “+” key
- (2) “-” key

The needle drop position will change, while the stitch width (2.8 mm) remains consistent.

The distance between the left needle drop position and guide of the foot is indicated in millimeters.

NOTE:

You can alter the stitch width by changing the right needle drop position.

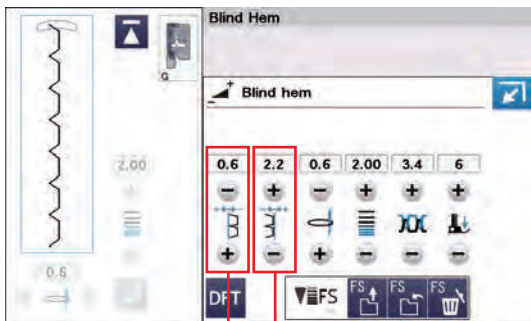

(1) (2)

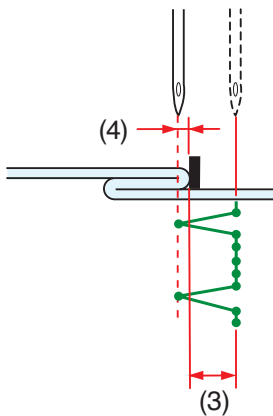

(3)

Altering blind hem stitch width

Press the “+” key in (2) to increase the stitch width (3).
Press the “-” key in (2) to decrease the stitch width (3).

NOTE:

You can move the left needle drop position (4) with the “+” or “-” key in (1).

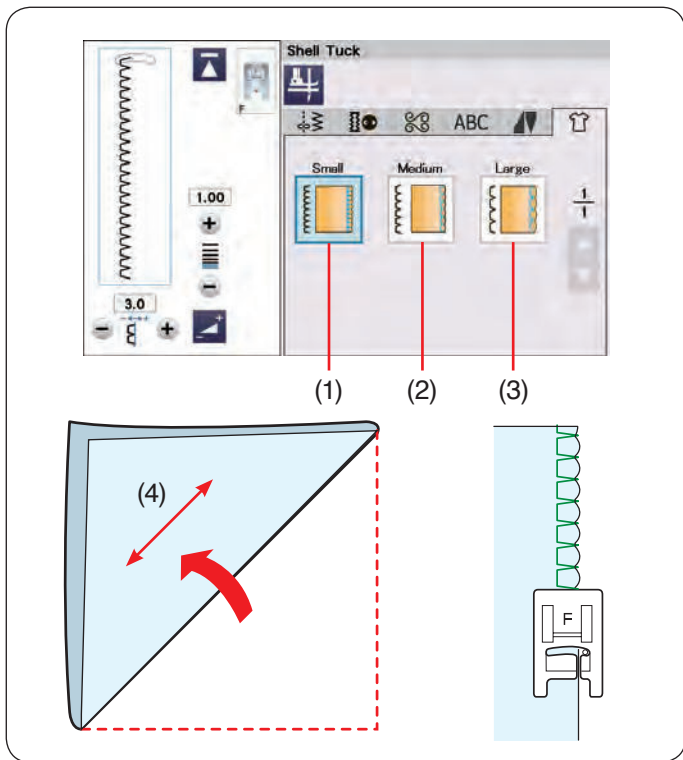

Shell Tuck

The following 3 options are available.

- (1) Small
Narrow shell tuck stitch
- (2) Medium
Medium width shell tuck stitch
- (3) Large
Regular shell tuck stitch

To sew:

Use a light weight fabric (Tricot, for example).
Fold the fabric in bias as shown and stitch on the fold.

- (4) Bias direction

Allow the needle to barely clear the folded edge to create a shelled edge.

If you sew shell tucks, space the rows at least 1.5 cm (5/8") apart.

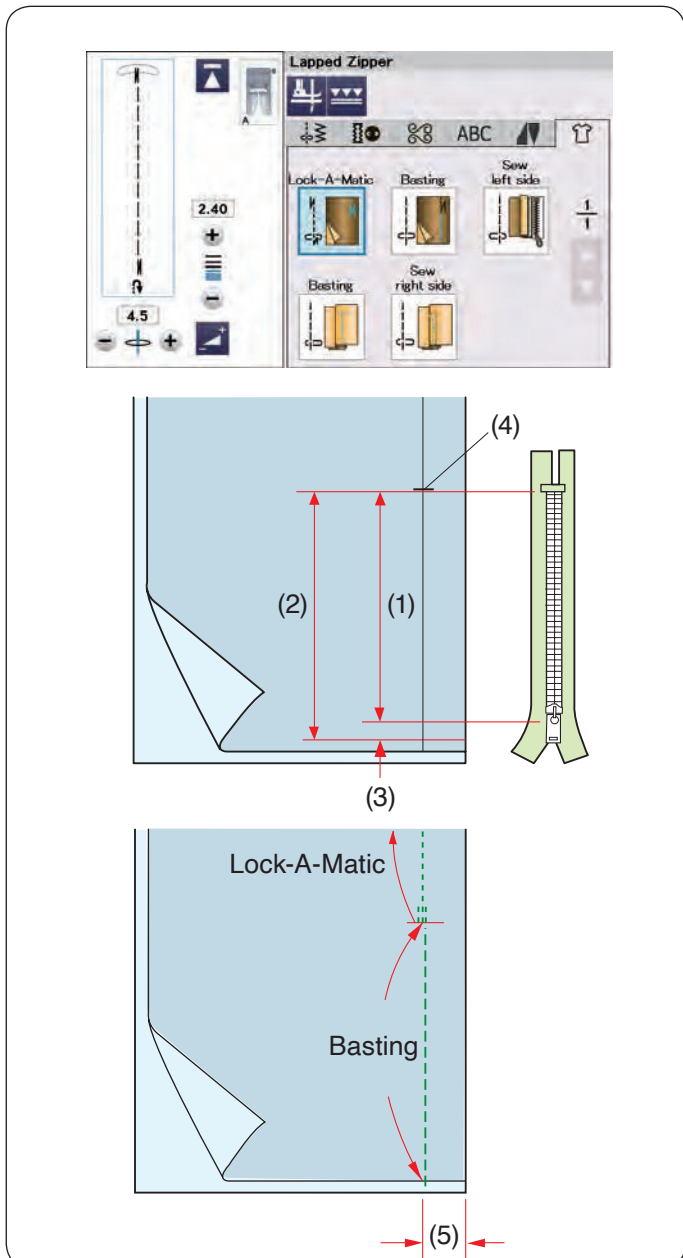

Lapped Zipper

Press the lapped zipper key and the zipper sewing window will open.

Press the sewing step key and the machine setting will automatically adjust to suit each sewing step.

NOTE: Dual feed plus foot VD* and dual feed plus zipper foot ED* appear on the visual touch screen when the dual feed key is pressed. Dual feed plus zipper foot ED* is used with dual feed plus foot VD* together.

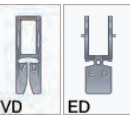

* Dual feed feet and holder are optional items (sold separately).

Fabric preparation

Add 1 cm (3/8") to the zipper size. This is the overall opening size.

Mark the end of opening.

- (1) Zipper size
- (2) Opening size
- (3) 1 cm (3/8")
- (4) End of opening

Attach the zigzag foot A.

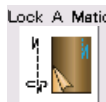

Lock-A-Matic

Place the right sides of the fabric together and sew to the end of the opening leaving a 2 cm (3/4") allowance.

- (5) 2 cm (3/4")

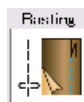

Basting

Baste the zipper opening.

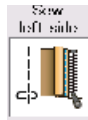

Sew left side

Replace the foot with zipper foot E.

Fold back the left seam allowance. Turn the right seam allowance under to form a 0.2 cm to 0.3 cm (1/8") fold. Place the zipper teeth next to the fold and pin in place.

- (6) 0.2 cm - 0.3 cm (1/8")
- (7) Zipper teeth
- (8) Fold

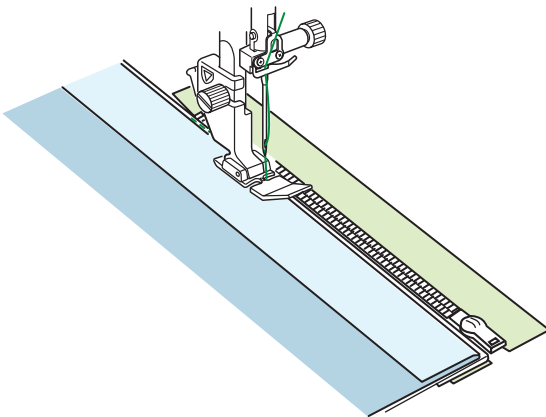
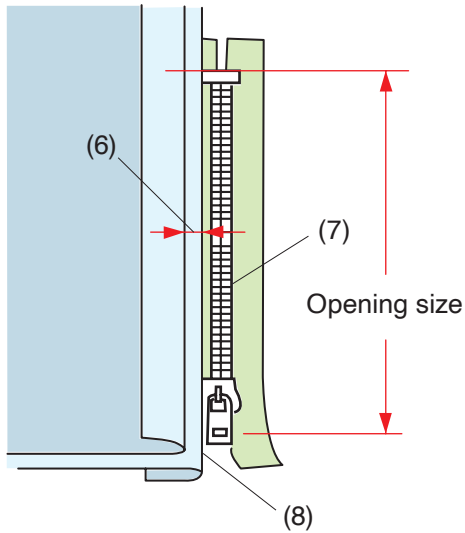

Lower the foot onto the topside at the bottom of the zipper so that the needle pierces the fabric next to the fold and the zipper tape. Sew along the zipper guiding the zipper teeth along the bottom edge of the foot.

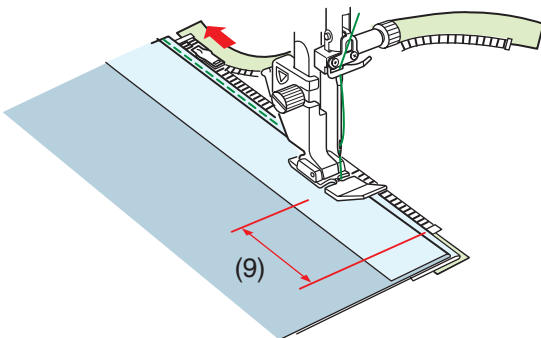

Sew through all layers next to the fold.

Stop 5 cm (2") before zipper foot E reaches the slider on the zipper tape.

- (9) 5 cm (2")

Lower the needle into the fabric, raise the foot and open the zipper. Lower the foot and stitch the remainder of the seam.

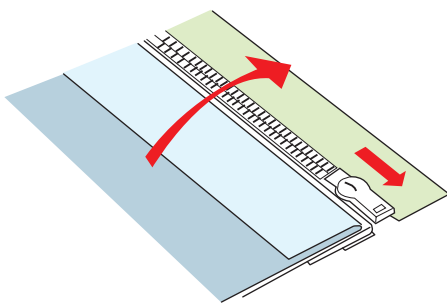

Close the zipper and spread the fabric open flat with the right side of the fabric facing up.

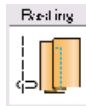

Basting

Baste the opened fabric and zipper tape together.

(10) Basting



Sew right side

Backstitch across the end of opening to 1 cm (3/8"). Stitch through the garment and zipper tape, guiding the zipper teeth along the bottom edge on the foot. Stop about 5 cm (2") from the top of the zipper. Lower the needle into the fabric, raise the foot and remove the basting stitches (refer to page 110).

(11) Basting stitches

Open the zipper and move the slider to the rear of the foot.

Lower the foot and stitch the remainder of the seam making sure the fold is even.

Remove the basting stitches.

(10) Basting

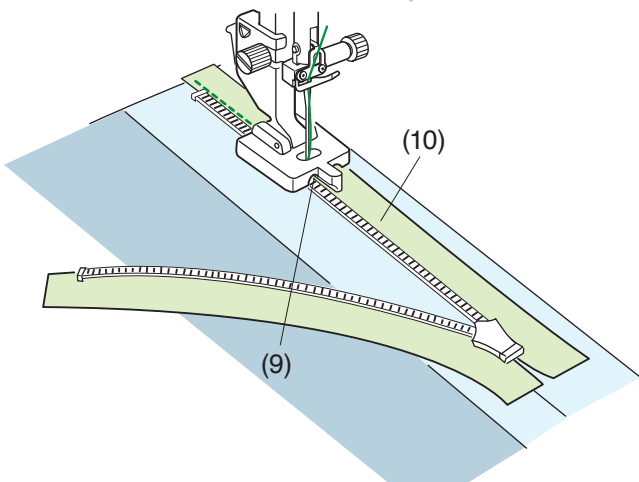
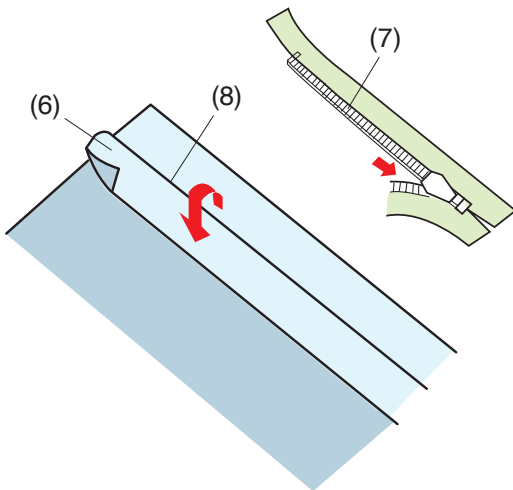
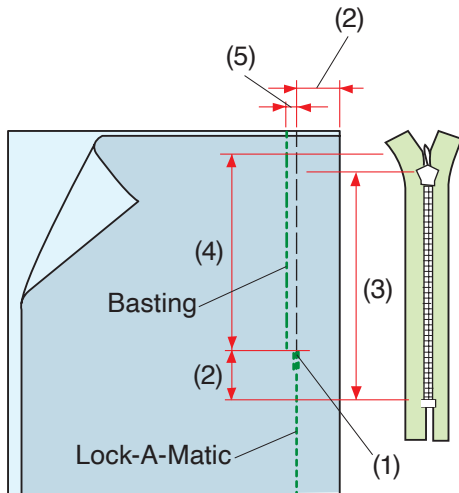
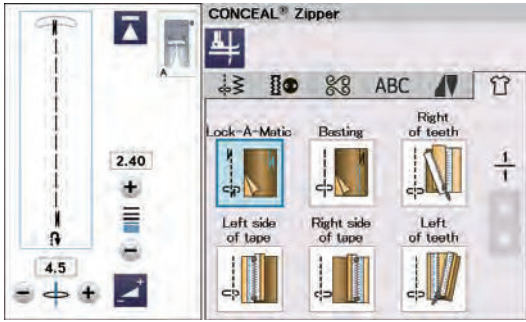

Invisible Zipper

Press the Invisible Zipper/CONCEAL® Zipper* key and the window will show the step-by-step keys.

Prepare an invisible zipper 2 cm (3/4") longer than the opening size.

Press the sewing step key and machine settings will automatically adjust to suit each sewing step.

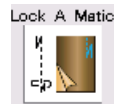

Lock-A-Matic

Attach zigzag foot A. Place the right sides of the fabric together and sew to the end of the opening with a 2 cm (3/4") seam allowance. Press the reverse button to lock the seams.

- (1) End of opening
- (2) 2 cm (3/4")
- (3) Zipper size
- (4) Opening size

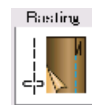

Basting

Baste the opening 0.3 cm (1/8") inside of the seam line.

- (5) 0.3 cm (1/8")

Fold up the left seam allowance to the bodice. Open the zipper and put it on the right seam allowance with the back side up.

Place the right zipper teeth next to the fold and pin it in place.

- (6) Left seam allowance
- (7) Zipper teeth
- (8) Fold



Right of teeth

Replace the foot with invisible zipper foot Z.

Raise the zipper teeth on the right and lower the foot so the left groove of the foot catches the zipper teeth. Stitch through the zipper tape and fabric up to the end of the opening.

Reverse the stitches to secure the seam.

- (9) Left groove
- (10) Zipper tape

* "CONCEAL" is a registered trademark of YKK Corporation.

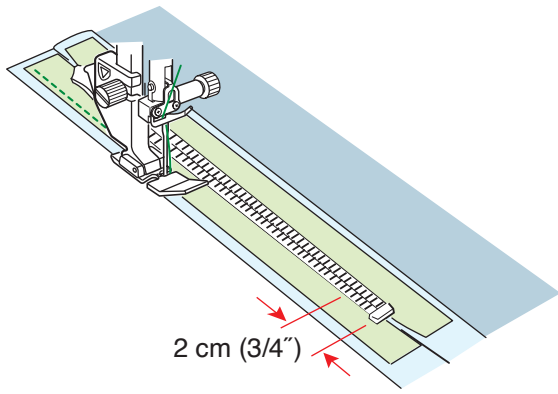

2 cm (3/4")

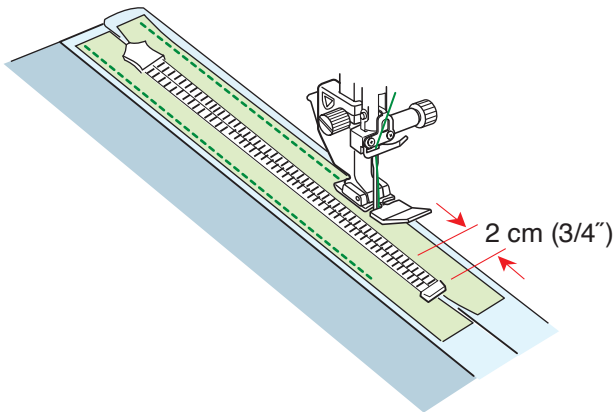

2 cm (3/4")

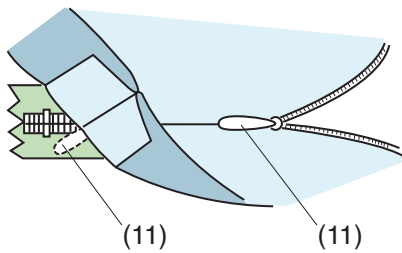

(11)

(11)

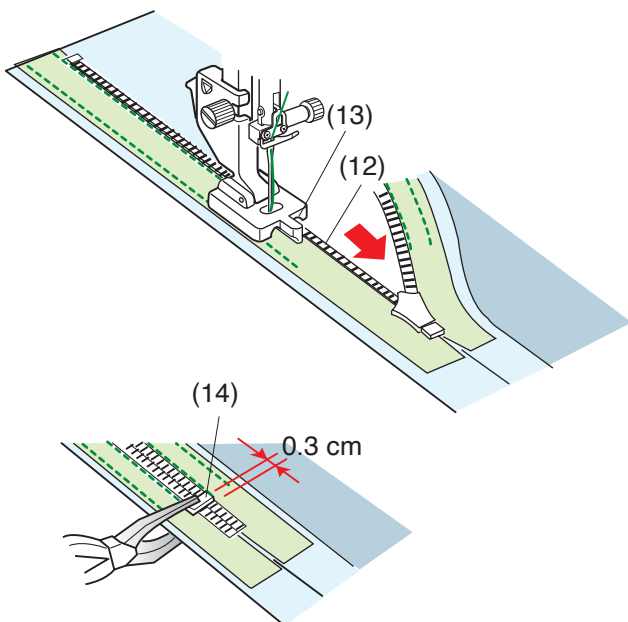

(13)

(12)

(14)

0.3 cm



Left side of tape

Raise the foot and close the zipper.
Replace the foot with zipper foot E.
Turn and fold the bodice to the right. Seam along the edge of the left zipper tape and reverse the stitches 2 cm (3/4") before the zipper bottom.

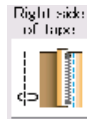

Right side of tape

Turn and fold the bodice to the left.
Seam along the edge of the right zipper tape and reverse the stitches 2 cm (3/4") before the zipper bottom.



Left of teeth

Raise the foot and replace it with invisible zipper foot Z.
Remove the basting stitches.
Open the zipper and insert the pull tab between fabric and zipper tape to allow the slider to reach the stopper.

(11) Pull tab

Raise the zipper teeth on the left and lower the foot so the right groove of the foot catches the zipper teeth.
Stitch through the zipper tape and fabric up to the end of the opening. Reverse the stitches to secure the seam.

(12) Zipper teeth

(13) Right groove

Slide up the stopper to 0.3 cm (1/8") below the end of the opening and fasten the stopper with pliers.

(14) Stopper

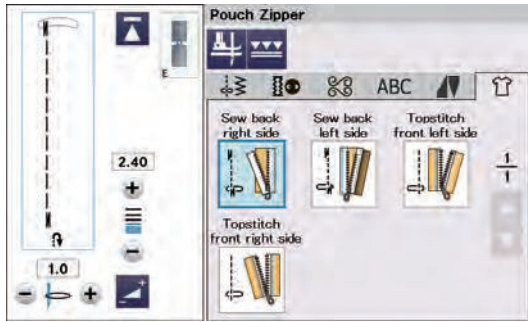

Pouch Zipper

Press the pouch zipper key and the window will show the step-by-step keys.

Prepare 2 pieces of fabric and a zipper tape.

NOTE:

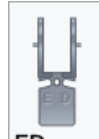

Dual feed plus zipper foot ED* appears on the visual touch screen when the dual feed key is pressed.

Use the dual feed plus zipper foot ED* instead of zipper foot E.

* Dual feed plus zipper foot ED (single) and the holder (single) are optional items (sold separately).

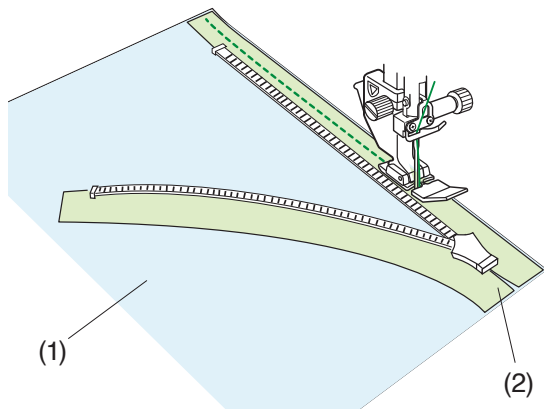

Sew back right side

Attach zipper foot E.

Open the zipper.

Place the right sides of the fabric and zipper tape together aligning both right edges.

Seam along the zipper aligning the right edge of the foot and zipper tape.

Stop 5 cm (2") before zipper foot E reaches the slider on the zipper tape. Close the zipper and stitch the remainder of the seam.

- (1) Right side of the fabric A
- (2) Wrong side of the zipper tape

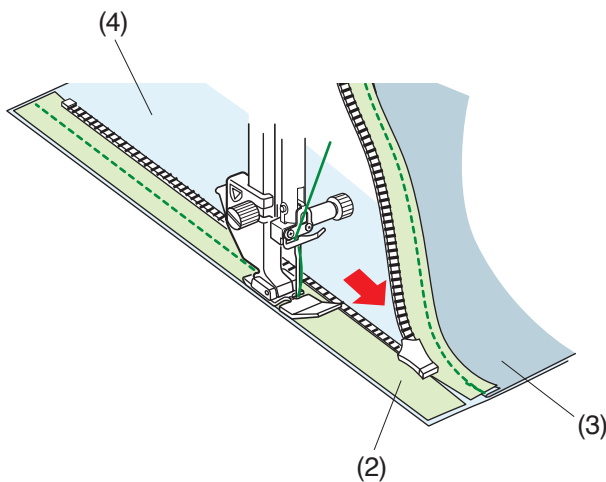

Sew back left side

Fold back the right seam allowance.

Place the right sides of the other fabric and zipper tape together aligning both left edges.

Open the zipper and seam along the zipper aligning the left edge of the foot and zipper tape.

Stop 5 cm (2") before zipper foot E reaches the slider on the zipper tape. Close the zipper and stitch the remainder of the seam.

- (2) Wrong side of the zipper tape
- (3) Wrong side of the fabric A
- (4) Right side of the fabric B

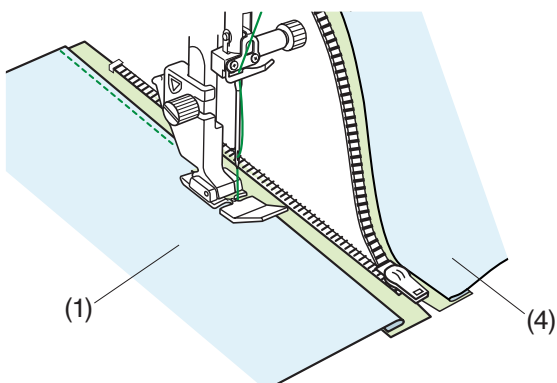

Topstitch front left side

Fold back the seam allowance.

Spread the fabric open flat with the right side of the fabric facing up. Open the zipper.

Stitch along the fold of fabric, aligning the right side of the zipper foot with the folded edge.

Stop 5 cm (2") before zipper foot E reaches the slider on the zipper tape. Close the zipper and stitch the remainder of the seam.

- (1) Right side of the fabric A
- (4) Right side of the fabric B

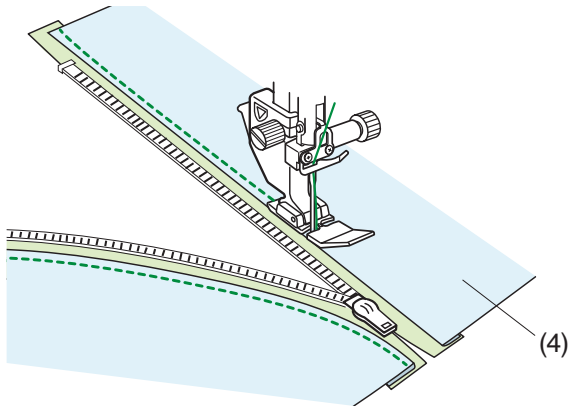

Topstitch front right side

Open the zipper. Stitch along the fold of fabric, aligning the left side of the zipper foot with the folded edge.

Stop 5 cm (2") before zipper foot E reaches the slider on the zipper tape. Close the zipper and stitch the remainder of the seam.

- (4) Right side of the fabric B

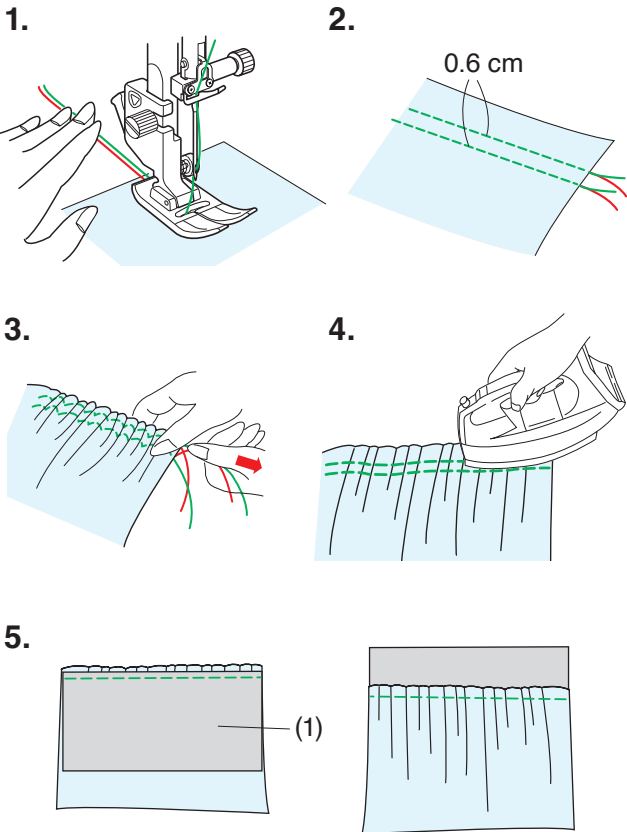

Gathering

1. Pull both threads 10 cm (4") under and behind the presser foot (refer to page 33).
2. Sew two rows of straight stitches 0.6 cm (1/4") apart. Knot the threads at the beginning.
3. Pull the bobbin threads at the end to gather the fabric.
4. Knot the threads at the end and distribute the gathers evenly.
5. Prepare the fabric to attach the gathering.

Exit the sewing application.

Select the Straight Stitch U1.

Set the thread tension to "3.4" and the stitch length to "2.40" (default settings).

Place the wrong side of the fabric under the gathering.

(1) Wrong side of the fabric

Sew the straight stitch between the two gathering rows.

Remove the two rows of straight stitches.

NOTE:

You may sew the straight stitch under the two gathering rows to cover the remains of gathering rows.

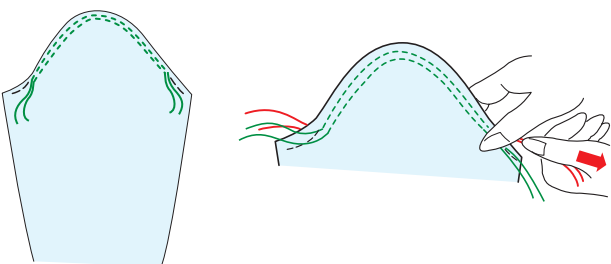

Easestitching

In addition to the regular gathering stitch, this section offers you a special stitch for easing sleeve tops.

Pull both of the threads about 10 cm (4").

Sew a pair of lines, 0.3 cm (1/8") apart, along the edge of the sleeve top.

Pull the bobbin threads to contract the sleeve top carefully, matching it with the armhole size.

Make sure not to make gathers in the sleeve top.

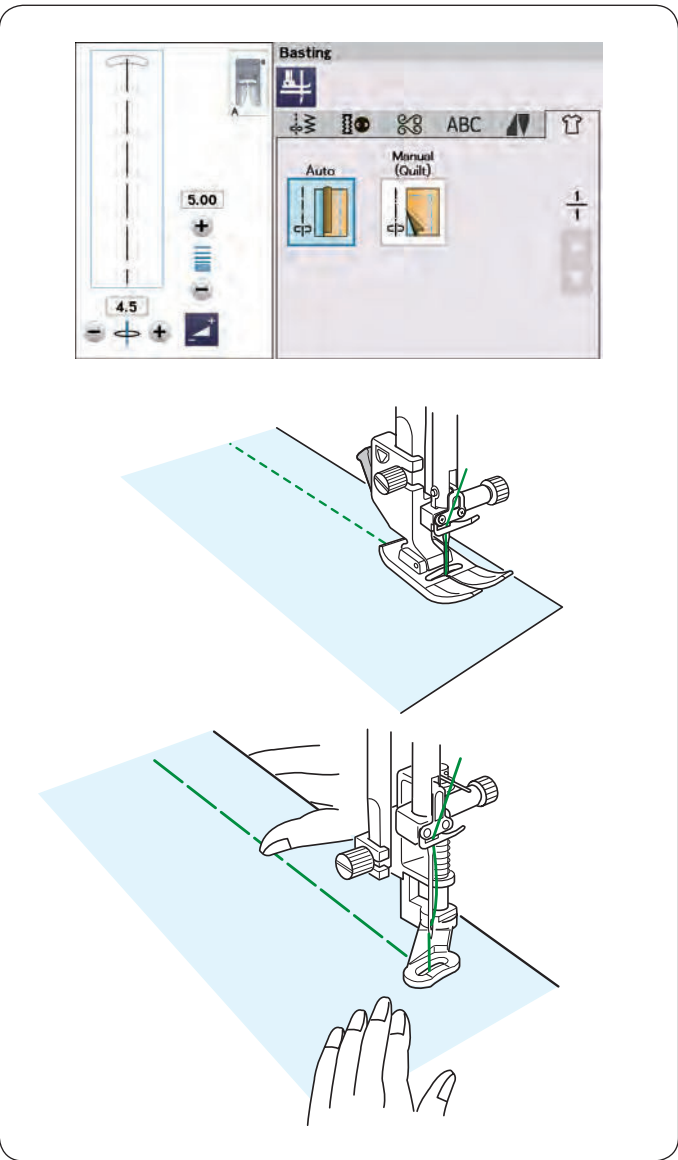

Basting

There are 2 basting stitches available in this section.

Basting (Auto)

This stitch is used for basting zipper tape or fitting of garments.

Sew in the same way as that for straight stitch sewing.

Basting (Manual/Quilting)

Attach the darning foot PD-H.

To sew

Hold the fabric taut and depress the foot control.

The machine will sew one stitch and stop automatically.

Slide the fabric to the rear for the next stitch.

NOTE:

Refer to page 24 for how to attach the darning foot PD-H.

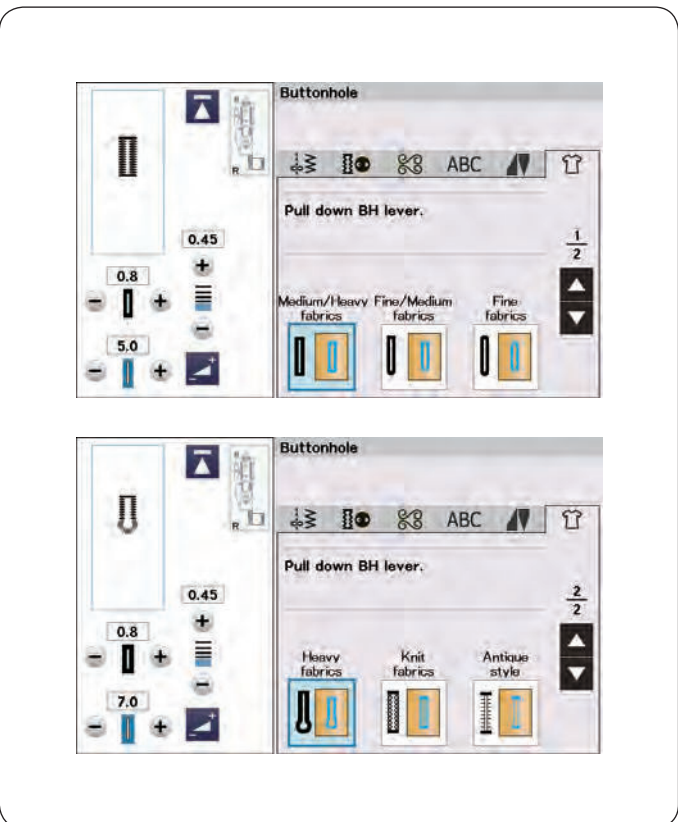

Buttonhole

Please refer to pages 57-64 for "BUTTONHOLES AND SPECIALTY STITCHES".

Medium/Heavy fabrics

Please refer to pages 57-60 for "B1 Sensor (Square) buttonhole".

Fine/Medium fabrics

Please refer to page 64 for "B3 Round end buttonhole".

Fine fabrics

Please refer to page 64 for "B4 Fine fabric buttonhole".

Heavy fabrics

Please refer to page 64 for "B5 Keyhole buttonhole".

Knit fabrics

Please refer to page 64 for "B11 Knit buttonhole".

Antique style

Please refer to page 64 for "B12 Antique buttonhole".

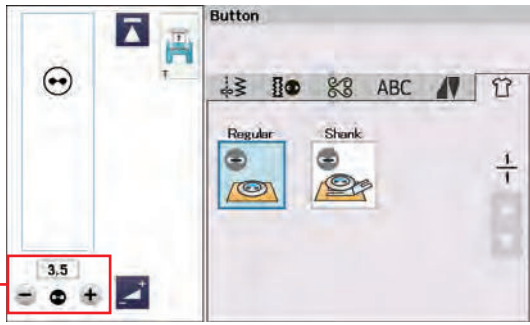

(4)

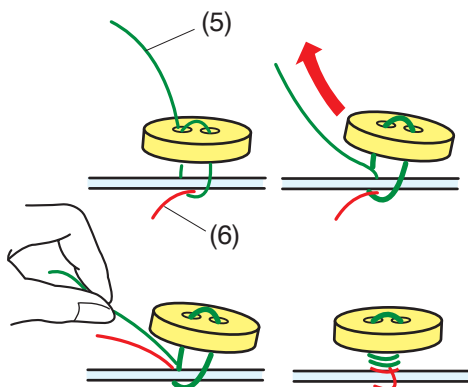
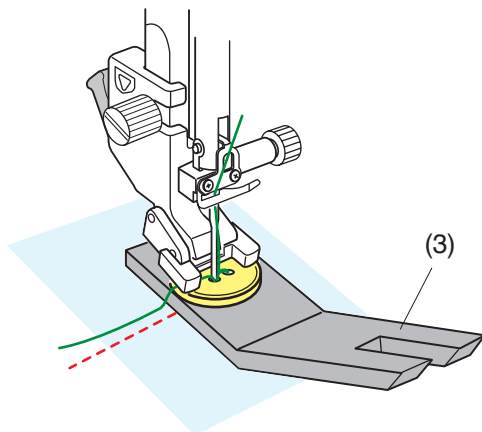
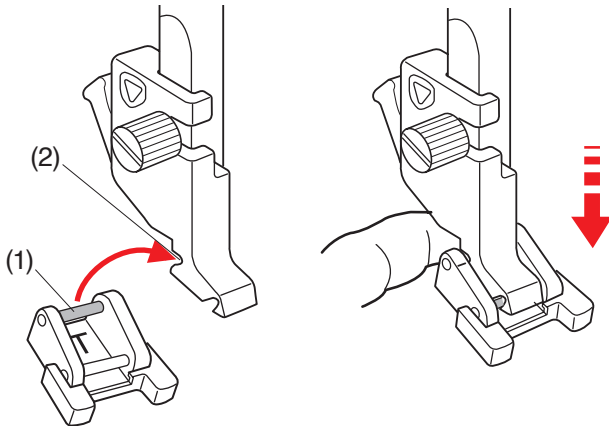

Button

Select "Regular" or "Shank" for attaching button.

For attaching a button to thick fabric, you need to make a shank by using the button shank plate.

The feed dogs lower automatically when selecting the button sewing section.

Attaching the button sewing foot T

Make sure to press the lockout key to lock the machine. Raise the presser foot with the presser foot lifter.

Insert the rear pin of the foot into the rear groove of the foot holder.

- (1) Rear pin
- (2) Rear groove

Gently lower the presser foot lifter while holding the foot with your finger to fit the foot. Press the lockout key to unlock the machine.

To sew

Select the  key to make a shank by using the button shank plate.

Place a button on the fabric and lower the needle into the left hole of the button by turning the handwheel with your hand.

Insert the button shank plate under the button.

Lower the foot to hold the button in place, aligning the direction of the button.

- (3) Button shank plate

NOTE:

- The shank plate is double-sided.
- The shank plate has two types of thickness, 4.5 mm and 3 mm.
- Those thicknesses provide a space between the button and the garment for the tying.
- Choose the desired type at your convenience.

Raise the needle by turning the handwheel until the needle bar swings to the right.

Press the "+" or "-" key (4) so the needle enters into the right hole of the button. The maximum stitch width is 0.7 cm (1/4").

Start sewing and continue until the machine stops automatically.

Remove the fabric from the machine.

Cut the all threads leaving at least 10 cm (4") tails.

Trim the thread at the beginning close to the fabric.

Pass the needle thread at the end of stitching through the left hole in the button, between the button and fabric.

Pull the needle thread to bring the bobbin thread up to the right side of the fabric.

- (5) Needle thread at the end
- (6) Bobbin thread

Wind the threads to form a shank and knot them together.

NOTE:

The button shank plate cannot be used if the button is too thick.

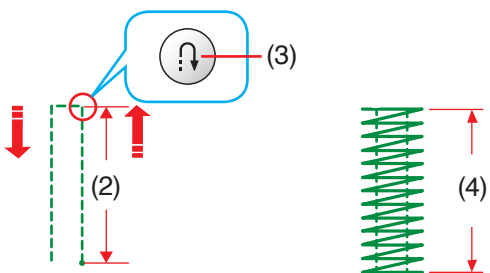
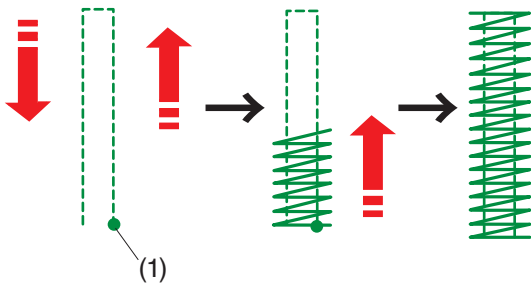
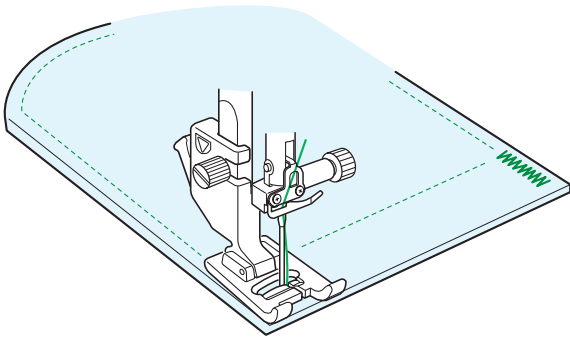
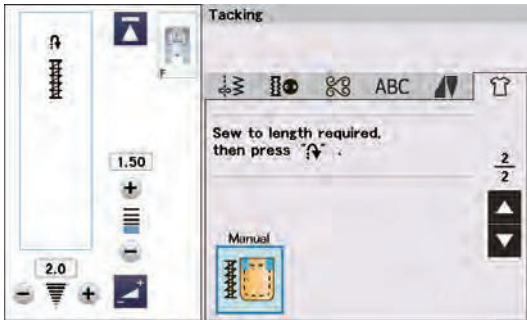

Restart for the same size.

Different size



Tacking

Tacking is used to reinforce pockets, crotches and belt carriers where extra strength is needed.

There are 3 auto tacking sizes and manual tacking available.

Attach satin stitch foot F.

Auto tacking

Lower the needle at the starting point and start sewing. The machine will sew the tack of the selected size and stop automatically when it is finished.

- (1) Starting point

Manual tacking

Start the machine and sew to the required length, then press the reverse button. This sets the tack length. Continue sewing until the machine stops automatically.

- (2) Required length
- (3) Reverse button
- (4) Tack length

NOTE:

- The maximum length of tacking is 1.5 cm (5/8").
- The memorized length will be cancelled if the presser foot is raised or the startover key (refer to page 89) is pressed before tacking is completed.

To sew the same size tack

To sew another tack in the same size, simply start the machine and sew until the machine stops automatically.

To sew the next tack in a different size, press the X key.

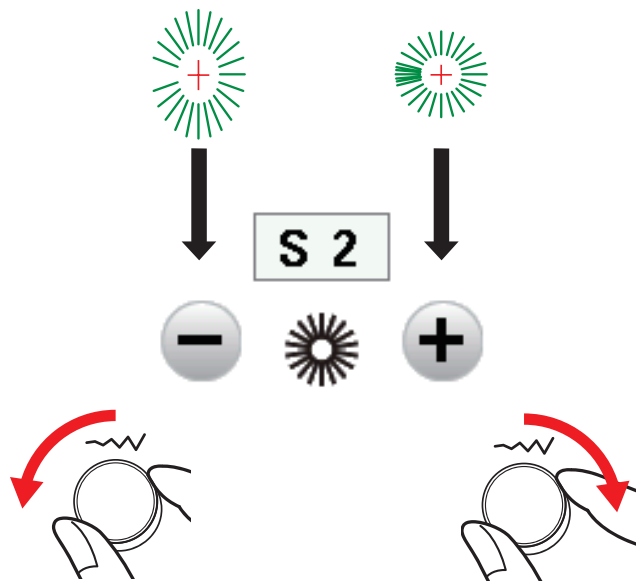
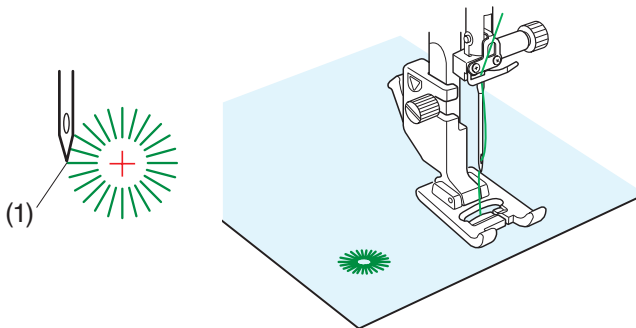
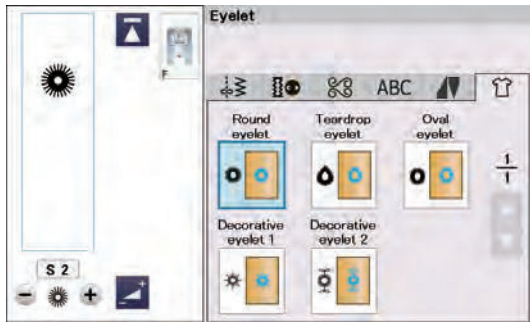

Eyelet

Eyelets are used for belt holes, etc.
Attach satin stitch foot F.

To sew:

Place the garment under the foot and lower the needle to the starting point.

Sew until the machine stops automatically.

(1) Starting point

Open the eyelet with an awl, punch or pointed scissors.

To correct the shape of an eyelet:

If the eyelet is open, turn the stitch width adjusting dial counterclockwise or press the “-” key.

If the eyelet overlaps, turn the stitch width adjusting dial clockwise or press the “+” key.

NOTE:

The shape can be adjusted within S1 to S3 (default setting is S2).

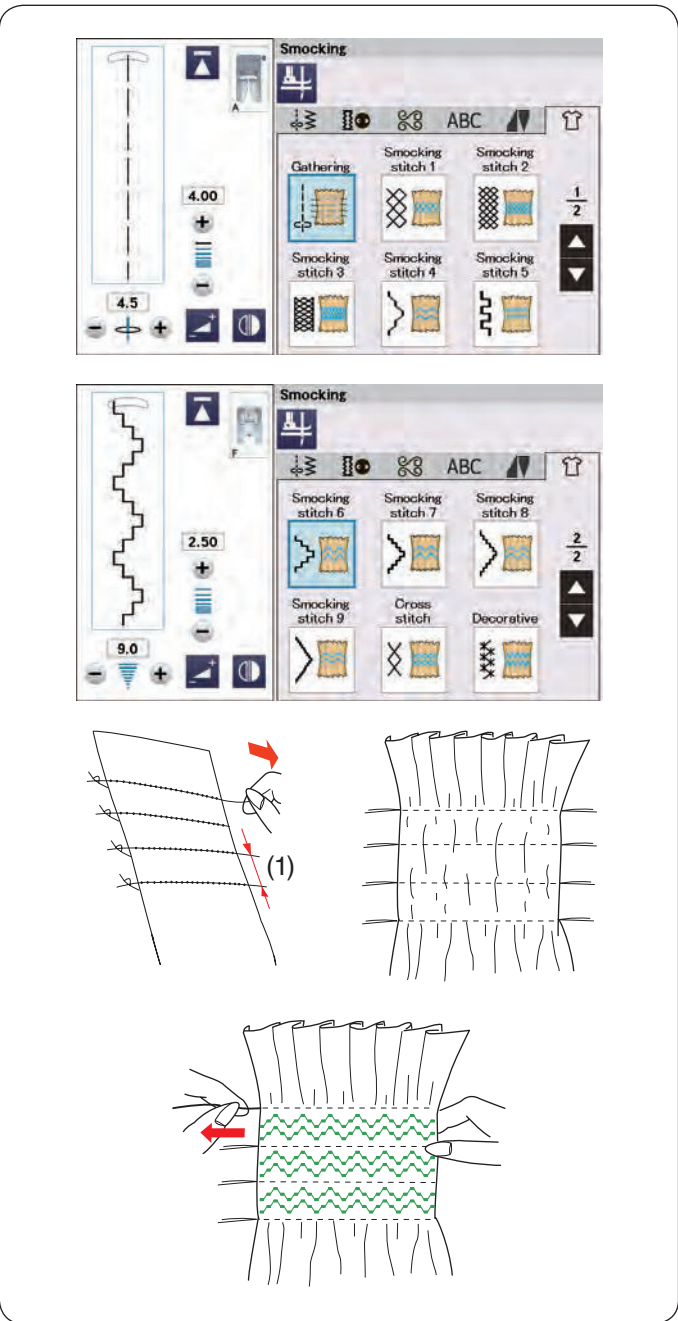

Smocking

Choose a soft, lightweight fabric such as batiste, gingham or challis. Cut the fabric three times wider than the projected width.

NOTE:
The purple tip needle is recommended to prevent skipped stitches.

Gathering

Sew rows of straight stitches, 1.5 cm (5/8") apart to across the area to be smocked.

- (1) 1.5 cm (5/8")

Tie the threads along one edge. Pull the bobbin threads at the end to gather the fabric. Knot the threads at the end and distribute the gathers evenly. Use an iron to press the gathered fabric.

NOTE:
Pull up the bobbin thread and draw a 10 cm (4") thread tail to the back before starting to sew. Use the thread cutter on the face plate.

Smocking stitch

Select a smocking stitch. Sew the smocking stitches between the gathered rows. Remove the straight stitches between the gathered rows.

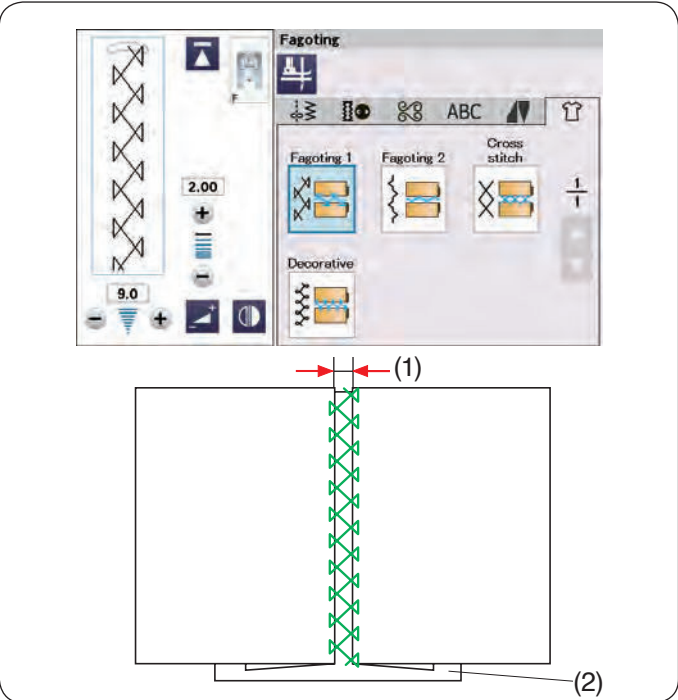

Fagoting

Use this stitch to join two pieces of fabric to create an open work appearance and add design interest.

Fold under each fabric edge 1.5 cm (5/8") and press. Pin the two edges to paper or tear away backing 0.3 cm (1/8") apart.

- (1) 0.3 cm (1/8")
- (2) Paper

Sew slowly, guiding the fabric so the needle catches the folded edge on each side. After finishing sewing, tear away the paper.

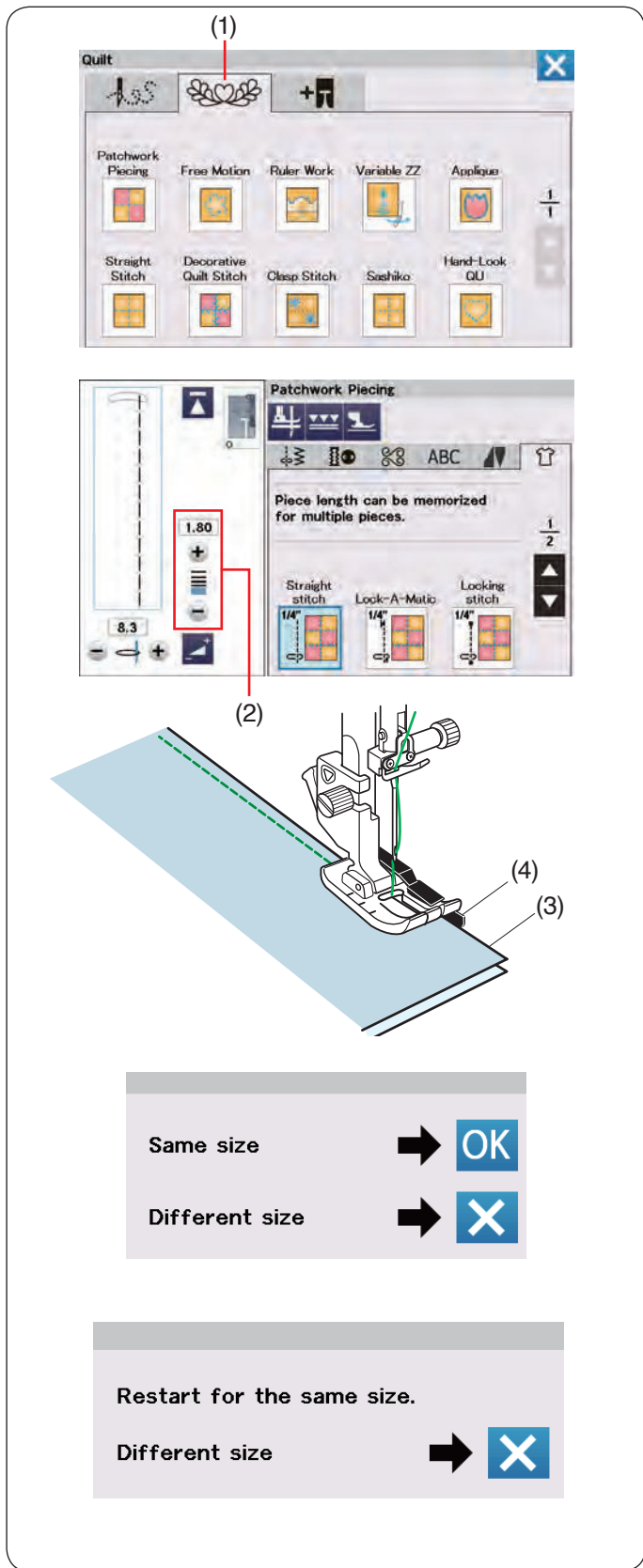

Quilt

Press the quilt tab and the quilt sewing application menu will open.

(1) Quilt tab

Patchwork Piecing

There are 6 stitches for seaming patchwork pieces in this section.

The default stitch length is set at 1.8 mm, ideal for patchwork piecing, but you can fine tune the stitch length by pressing the “+” or “-” key.

(2) Stitch length adjusting key

Attach 1/4” seam foot O, which helps you to keep a constant 1/4” (6 mm)* seam allowance.

Put 2 pieces of fabric with right sides together.

Place the patchwork pieces under the foot so that the edge of the fabric matches the guide on the presser foot.

(3) Edges of fabric

(4) Guide on the 1/4” seam Foot

* You can choose 1/4” (6 mm) or 7 mm seam allowance. Keys for 7 mm seam allowance are displayed on the next page (2/2).

When you stop the machine, a message will appear.

Press the OK key and the machine memorizes the seam length to sew another piece of the same length.

Press the X key to sew in a different size.

After sewing the memorized length, a message will appear.

To sew the same length, start the machine and it will stop automatically after sewing the memorized length.

Press the X key to sew in a different size.

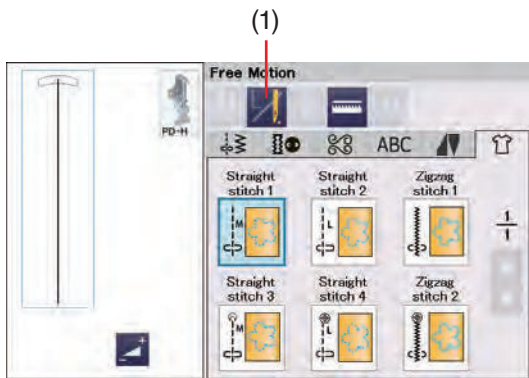

Free Motion

The straight stitch needle plate is recommended for “Straight stitch 1”, “Straight stitch 2”, “Straight stitch 3” and “Straight stitch 4” (refer to page 34 for how to replace the needle plate).

For ordinary and bulky quilts, select “Straight stitch 1”, “Straight stitch 2” or “Zigzag stitch 1” and use the darning foot PD-H (refer to page 24 for how to attach the darning foot).

Select the “Straight stitch 3”, “Straight stitch 4” or “Zigzag stitch 2” for flatter quilts and use the free quilting foot QC, QO or QV.

Refer to page 119 (same as button sewing foot T) for how to attach the free quilt feet.

One Stitch Off

The machine stops automatically after sewing one stitch so that you can bring the bobbin thread up to prevent it from bunching up on the wrong side of the fabric. Leave a 10 cm (4”) tail of bobbin thread.

Hold the needle thread and start the machine. Sew one stitch and the machine stops automatically.

Pull the needle thread up to bring the bobbin thread up.

Hold both the needle and bobbin threads and sew several stitches to secure the threads.

You can trim the thread tails with scissors.

The machine will stitch continuously when you resume sewing.

If you wish to start sewing without “one stitch off”, press the one stitch off key to cancel this function.

The key changes to .

When “one stitch off” is active, the key shows .

(1) One stitch off key

To sew

Sew at medium speed while guiding the fabric with your hands. Move the quilt 3 mm or less per stitch.

Foot Height for Free Motion Quilting

When “Straight stitch 3”, “Straight stitch 4” or “Zigzag stitch 2” is selected, the height of the down position of the free motion quilting feet (QC, QO, QV) is optimized automatically.

However, you can fine tune the foot height according to the quilt thickness.

Place the fabric under the foot and lower the foot.

Press the adjust key and the manual setting window will open. Adjust the foot height by pressing the “+” key or “-” key.

(2) Adjust key

(3) Presser foot height adjusting key

Reduce the height if the fabrics bounce when sewing.

Increase the height if the foot gets trapped in the fabrics when sewing.

NOTE:

- The purple tip needle is recommended to prevent skipped stitches.
- Do not move the quilt layers toward you when the open-toe foot is attached.

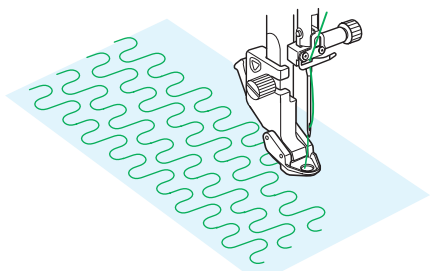
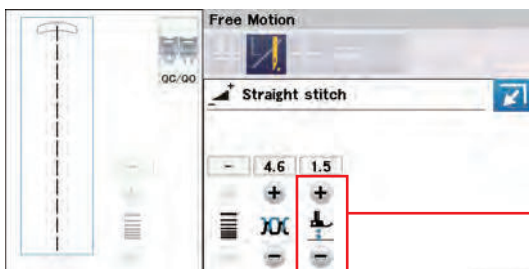
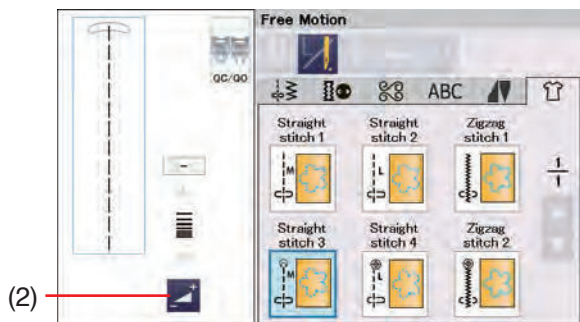
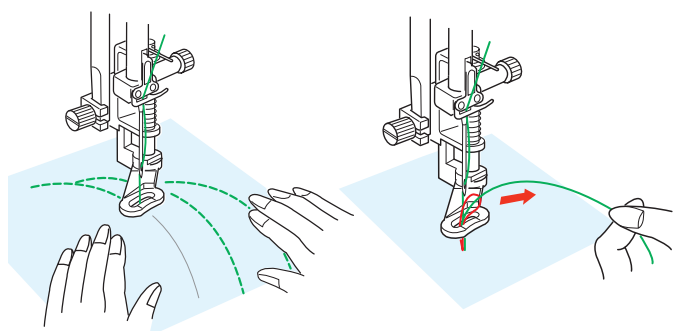

1.

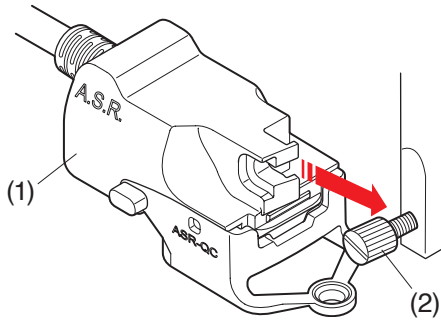

2.

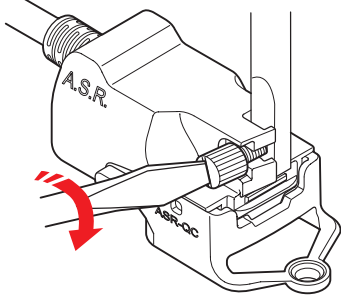

3.

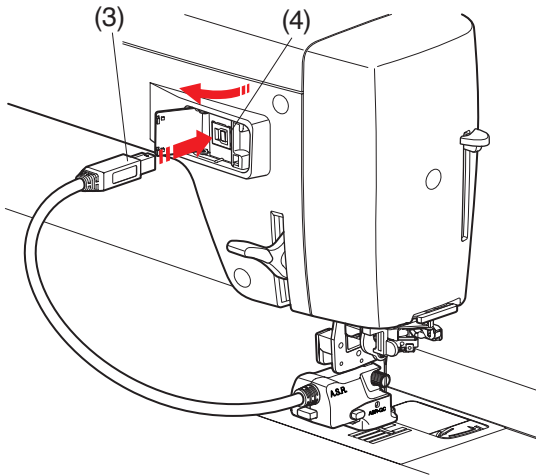

4.

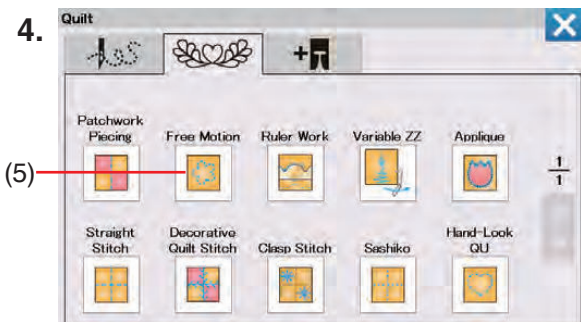

5.

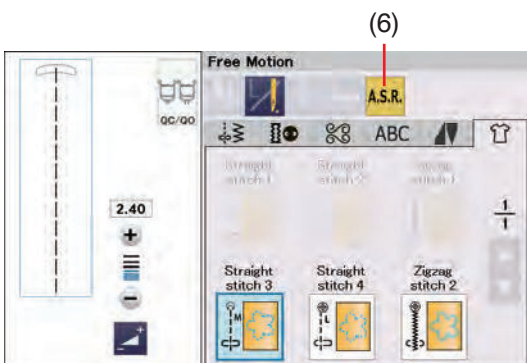

Accurate Stitch Regulator Function/A.S.R. Foot Holder

The A.S.R. foot holder (Accurate Stitch Regulator foot holder) reacts to movement of the fabric and provides the same stitch length for free motion, ruler work or variable zigzag.

1. Remove the foot holder (refer to page 22).

Attach the A.S.R. foot holder to the presser bar.

(1) A.S.R. foot holder

Tighten the thumbscrew with your fingers.

(2) Thumbscrew

2. Tighten the thumbscrew securely with the screwdriver.

3. Insert the A.S.R. plug into the attachment connector on the rear of the machine.

(3) A.S.R. plug

(4) Attachment connector

4. Press "Free Motion".

(5) Free Motion

The feed dogs drop automatically for free motion sewing.

5. Press "Straight stitch 3", "Straight stitch 4" or "Zigzag stitch 2".

Press the A.S.R. key.

(6) A.S.R. key

NOTE:

- Patterns not suitable for Accurate Stitch Regulator function are grayed out.
- The A.S.R. key will gray out if the A.S.R. plug is not inserted to the attachment connector.

6.

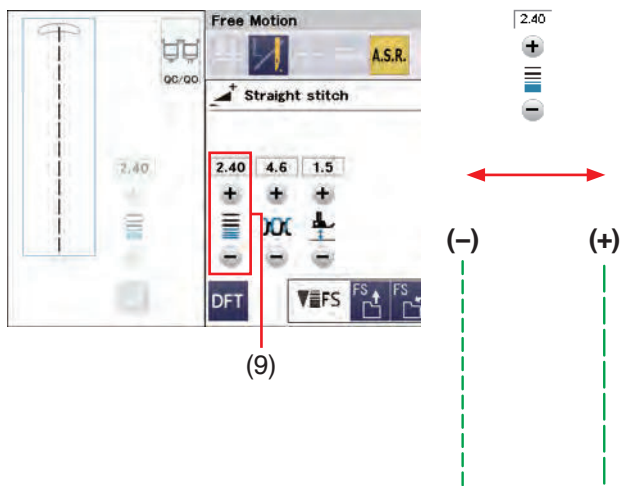
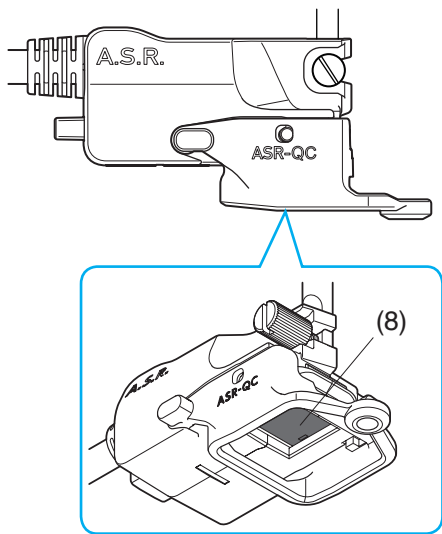
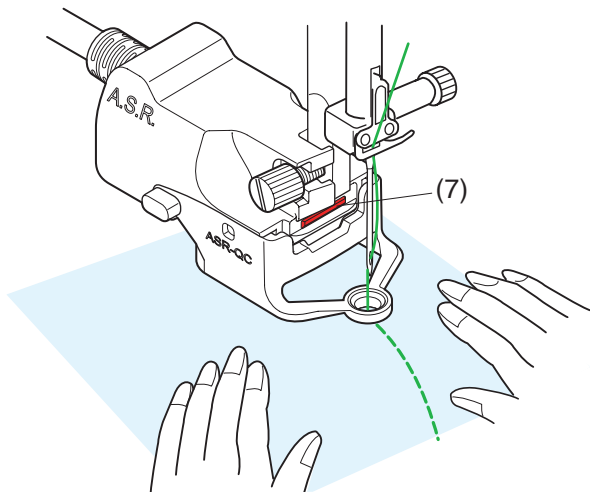

6. Sew the fabric while guiding it with your hands.
The status indicator will turn red during operation.
The buzzer sounds and the stitch length will be longer than the setting when the fabric moves too fast.

(7) Status indicator

* The A.S.R. foot holder also can be used with ruler work or variable zigzag (refer to pages 128 and 129).

7. Be sure to pull out the A.S.R. plug from the attachment connector on the back of the machine to remove the A.S.R. foot holder.

NOTE:

- Set the speed control slider at the fastest position (refer to page 14).
- Sewing results may vary depending upon sewing conditions. Always make a test stitch on an extra piece of fabric to check sewing results. Move the speed control slider to set the sewing speed to middle if the stitch length become too short when the fabric guiding with your hands.
- The machine sews at low speed when you are not guiding fabric.
- Accurate Stitch Regulator sensor cannot detect fabric movement in the area 2 cm (3/4") from the rear side edge of the fabric (the sensor only can detect the fabric movement under the sensor).
- The machine sews at low speed in the area 2 cm (3/4") from the edge of the fabric.
- Regularly check if the inside of the sensor on the underside of the A.S.R. foot holder is not dirty.
- Regularly clean the black window on the underside of the A.S.R. foot holder with a soft cloth.

(8) Sensor

Adjusting stitch length

The stitch length varies depending on (the color or thickness of) the fabric or the presser height.

Press the adjust key to adjust stitch length.

Press the "+" key to increase the stitch length.

Press the "-" key to decrease the stitch length.

(9) Stitch length adjusting key

NOTE:

The adjustable range of stitch length is 1.00 mm to 4.00 mm.

NOTE:

Remove the A.S.R. from the sewing machine when you use the semi-hard fabric cover.

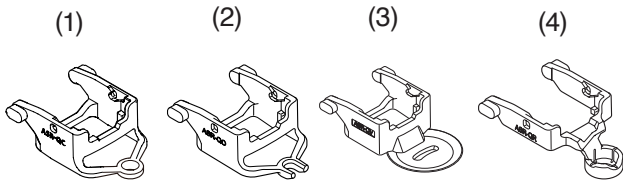

1.

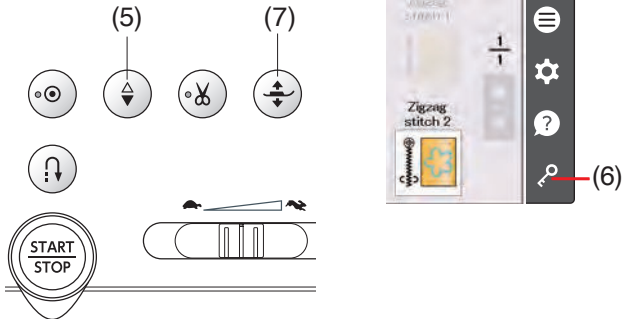

2.

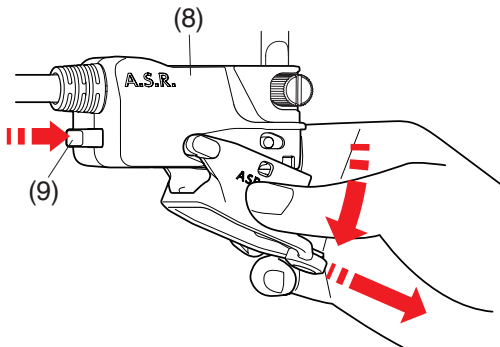
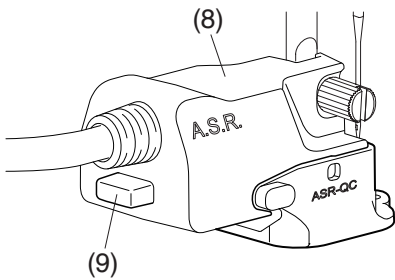

3.

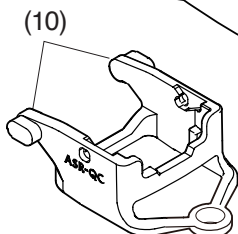
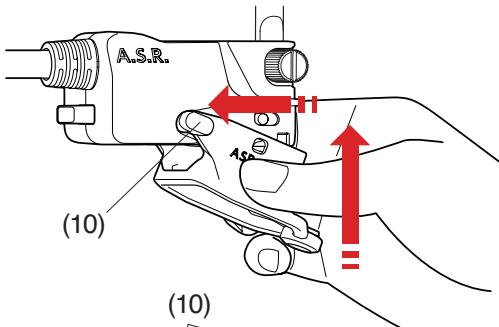

Changing the Foot Attachment

This foot holder comes with the A.S.R. closed-toe foot ASR-QC attached. However, it is also compatible with the A.S.R. open-toe foot ASR-QO, the A.S.R. clear view foot ASR-QV, and the A.S.R. ruler work foot ASR-QR.

- (1) A.S.R. closed-toe foot ASR-QC
- (2) A.S.R. open-toe foot ASR-QO
- (3) A.S.R. clear view foot ASR-QV
- (4) A.S.R. ruler work foot ASR-QR

Refer to pages 128 and 129 for ruler work or variable zigzag settings.

CAUTION:

Always make sure to press the lockout key before replacing the presser foot.

1. Press the needle up/down button to raise the needle. Press the lockout key. Press the presser foot lifter button to raise the presser foot.
 - (5) Needle up/down button
 - (6) Lockout key
 - (7) Presser foot lifter button
2. To remove the foot, pull the A.S.R. foot in the direction of arrows while pushing the button on the backside of the A.S.R. foot holder.
 - (8) A.S.R. foot holder
 - (9) Button
3. To attach the foot, set both ends to the A.S.R. foot holder and push the foot up to fit in place.
 - (10) Both ends

Ruler Work

CAUTION:

Do not lower the needle while the foot is raised, otherwise the needle clamp may hit the foot and cause injury or breakage.

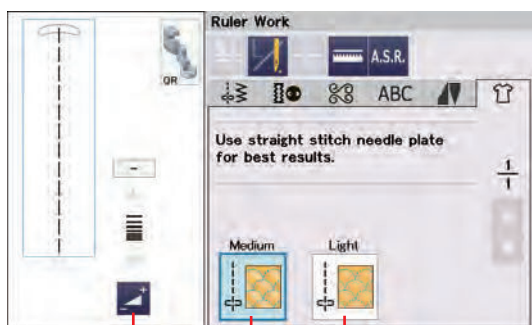

(3) (1) (2)

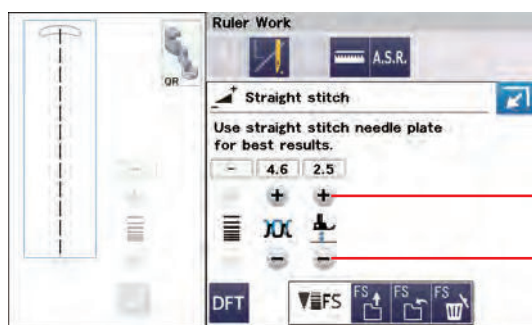

(4)

(5)

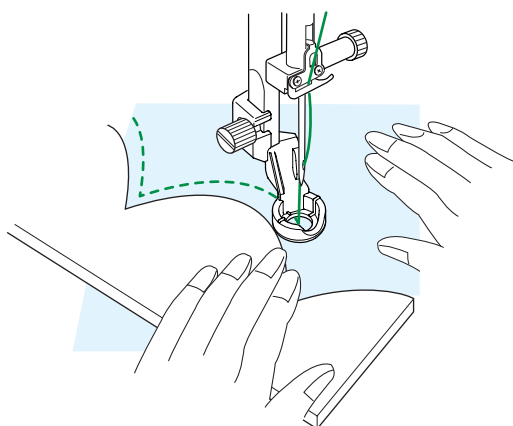

Guide the foot along the quilting template (optional) to create straight, curved or repetitious patterns depending on the shape of the ruler.

Attach the ruler work foot QR when "Ruler Work" is displayed as shown.

Use the straight stitch needle plate for better results (refer to page 25).

Refer to page 23 for how to attach the ruler work foot.

Place the fabric under the ruler work foot.

Adjust the presser foot height to suite the quilt thickness.

For ordinary and bulky quilts, select "Medium".

For flatter quilts, select "Light".

- (1) Medium
- (2) Light

You can finely adjust the presser foot height by pressing the "+" or "-" key on the manual setting window, press the adjust key to open the manual setting window.

- (3) Adjust key
- (4) "+" key
- (5) "-" key

Attach the A.S.R. foot and press A.S.R. key to use A.S.R. function (refer to pages 125-127).

Use the A.S.R. ruler work foot ASR-QR for ruler work.

Place the quilting template on the edge of the ruler work foot.

Sew while guiding the fabric and ruler together along the edge of the ruler work foot.

NOTE:

- A ruler (quilting template) for ruler work sewing is required.
- Use the ruler (quilting template) for high shank or long arm quilting machines (4.5 mm - 6.35 mm thickness).
- When you use the A.S.R. function, printing, marks or tape on the upper side of ruler can cause stitching length problems. Place printing, marks or tape on the lower side of the ruler.
- Opaque or colored rulers can cause stitching length problem. Use a transparent ruler.
- The purple tip needle is recommended to prevent skipped stitches.

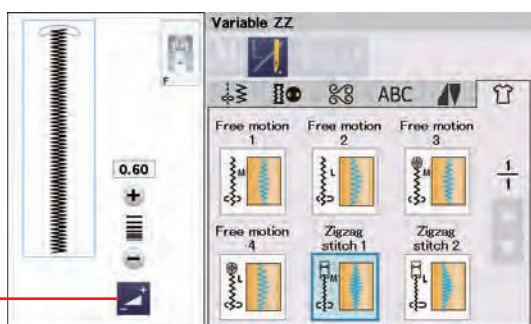
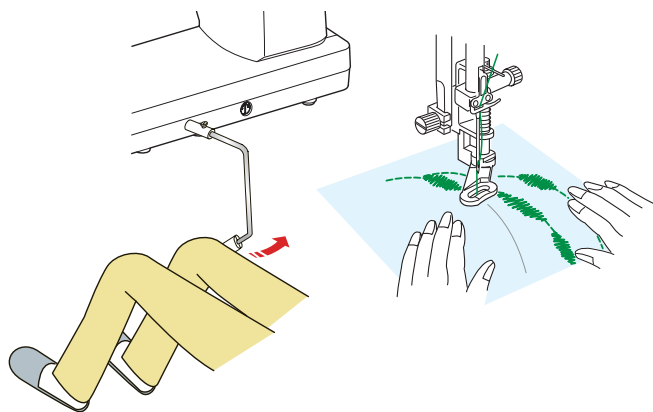
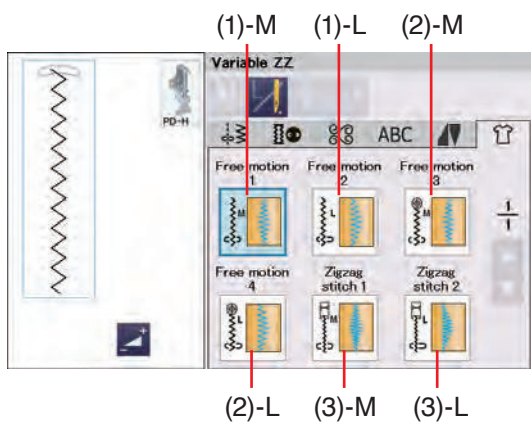

Variable ZZ

This unique feature allows you to control zigzag width with the knee lifter.

Select (1)-M or (1)-L, using the darning foot PD-H for sewing quilt layers. Guide the fabric with your hands while sewing.

Select (2)-M or (2)-L, using the free motion quilting zigzag foot QV or variable zigzag open-toe foot QZ (refer to page 119 for how to attach the foot: same as button sewing foot T) for sewing flat and firm fabrics. Guide the fabric with your hands while sewing.

The A.S.R. key can be used when selecting (2)-M or (2)-L (refer to pages 125-127).

Select (3)-M or (3)-L, using the satin stitch foot F for sewing variable zigzag stitches.

The fabric is fed by the feed dogs and the stitch width can be varied with the knee lifter.

Attach a stabilizer to the wrong side of the fabric if needed.

Sew at slow to medium speed while guiding the fabric with your hands and controlling the stitch width with your knee.

NOTE:

- When the machine stops, you can raise and lower the presser foot with the knee lifter.
- The purple tip needle is recommended to prevent skipped stitches.

Maximum Zigzag Width Adjustment

The maximum zigzag width can be limited to suit your sewing needs.

Press the adjust key to open the maximum zigzag width setting.

Press the “+” or “-” key beside the maximum zigzag width setting to limit the maximum zigzag width to your preference.

- (4) Adjust key
- (5) Maximum zigzag width setting

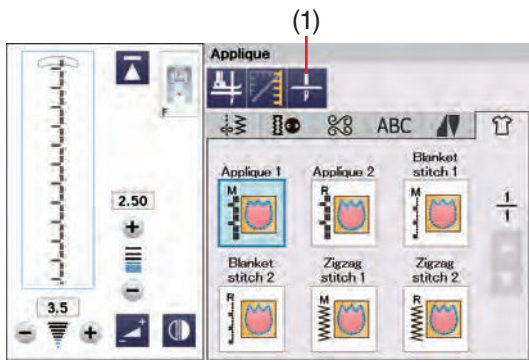

Applique

There are 6 types of applique stitches available in this section.

You can select the needle stop position to be either up or down by pressing the needle stop position key.

(1) Needle stop position key

The letter on the stitch image denotes the baseline of the needle drop position.

M: Middle (center)

R: Right

The baseline can be adjusted without changing the stitch width.

Press the adjust key to open the manual setting window. Press the “+” or “-” key to move the needle drop position (refer to page 48).

(2) Needle drop position adjusting key

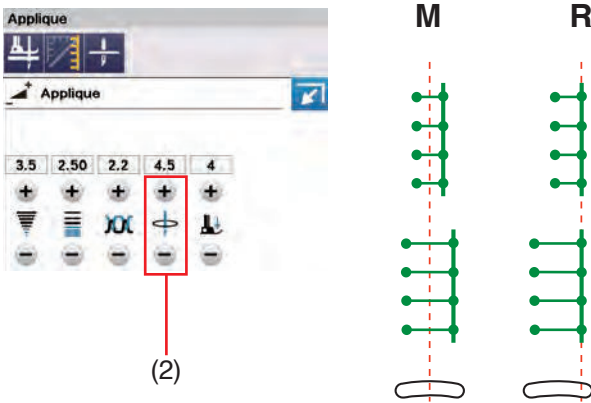

Pivoting at applique corners

When sewing an applique with sharp corners, you may turn on the “Foot up for pivoting” option so that the presser foot automatically goes up when the machine stops.

Press the foot-up key to turn on this option.

(3) Foot-up key

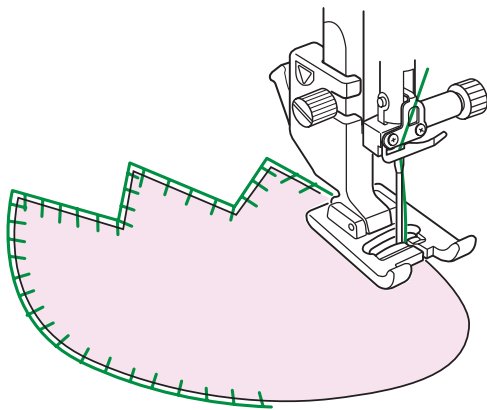

NOTE:

Make sure to stop the machine with the needle dropped at the outer edge of the applique.

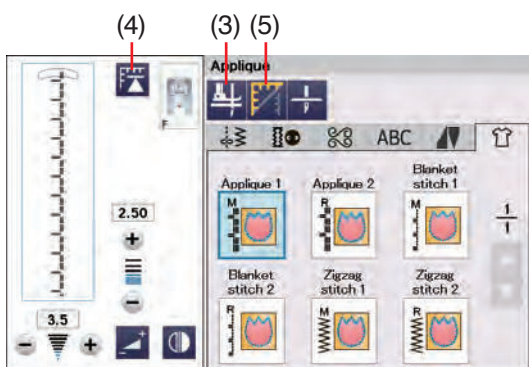

Starting over from the corner

Press the startover key before sewing in the new direction to sew from the beginning of the pattern.

(4) Startover key

Two of startover options are available for applique stitches. Press the cornering key to select normal startover or cornering startover.

The key will change to show which option is being selected when pressing the key.

(5) Cornering key

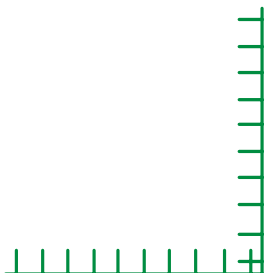

Normal startover:

Sew a locking stitch then start sewing from the beginning of the pattern.

Cornering startover:

Start sewing from the beginning of the pattern without a locking stitch.

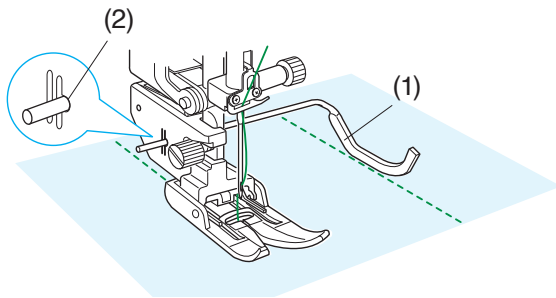
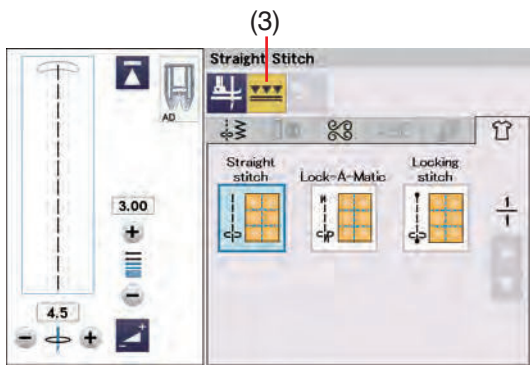

Straight Stitch (with Dual Feed)

Straight stitches in this section are suitable for seaming quilt layers using the dual feed foot (refer to page 23 for how to attach it). Refer to page 79 if you wish to use zigzag foot A with a quilting guide bar.

Quilting guide bar for dual feed foot

The quilting guide bar is helpful when sewing parallel, evenly spaced rows of stitching.

Insert the quilting guide bar into the hole in the rear of the foot holder.

Shift the quilting guide bar to the desired spacing.

- (1) Quilting guide bar
- (2) Hole

Press the dual feed key.

- (3) Dual feed key

Sew rows of stitching while tracing the previous row of stitches with the quilting guide bar.



Decorative Quilt Stitch

You can decorate the seam on the quilt or patchwork fabric with the decorative quilt stitches.

Use the satin stitch foot F.

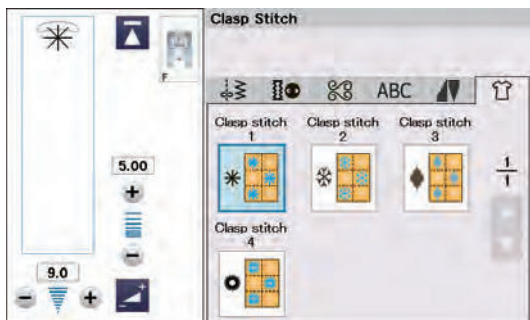

Clasp Stitch

You can close quilt layers and batting using the clasp stitch.

Use satin stitch foot F.

The machine sews one unit of the pattern and automatically stops with the needle in the up position when completed.

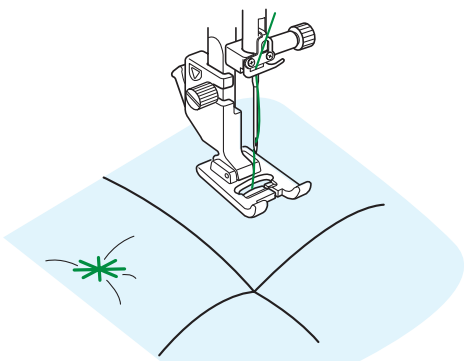

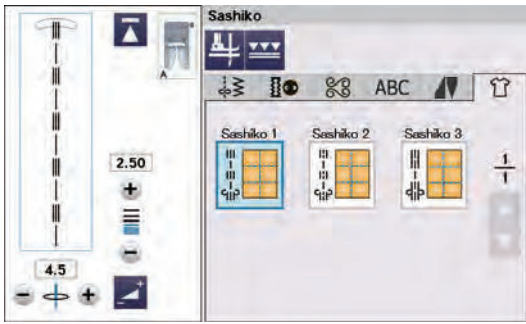

Sashiko

These stitches are used to create a mock Sashiko stitching.

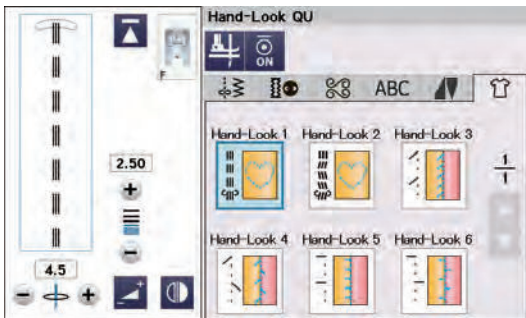

Hand-Look QU

Use a transparent nylon thread for the needle and ordinary sewing thread for the bobbin. The bobbin thread is pulled up on the right side of the fabric and the stitches will look as if sewn by hand.

INFORMATION AND CUSTOMIZING

Function Menu

Press the Function menu key to open the function menu.

- (1) Function menu key

You can select the following functions from this menu.

- (2) Quick Stitch Select
- (3) Quilt Block Advisor
- (4) Manual Dual Feed Setting
- (5) Machine Information

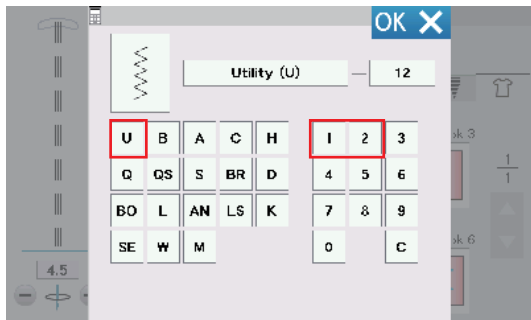
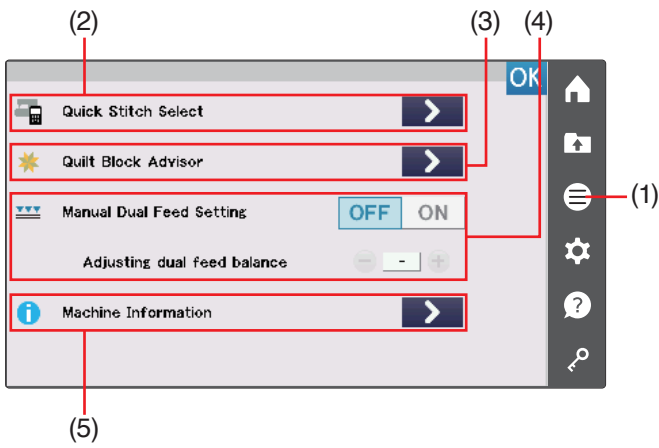

Quick Stitch Select

You can select the stitch pattern directly with the abbreviation of categories and numbers (refer to pages 35-36 for the abbreviation of categories).

Press the  key of the Quick Stitch Select to open the quick stitch selection window.

- (2) Quick Stitch Select

Example: To select utility stitch pattern 12;
Press “U” to select utility stitch pattern group.
Press “1” and then “2” to select the desired stitch pattern.
Press the OK key to select utility stitch pattern 12.

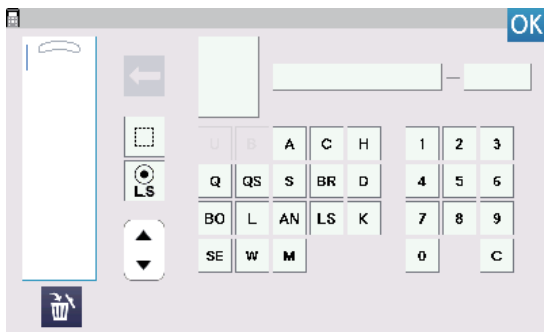

When programming a pattern combination, press the  key of the Quick Stitch Select to open the quick stitch selection window for programming mode.

- (2) Quick Stitch Select

NOTE:

You can not select utility and buttonhole stitch pattern groups (“U” and “B” are grayed out), when opening the quick stitch selection window for programming mode.

Example: To select satin stitch pattern 14;
Press “S” to select satin stitch pattern group.
Press “1” and then “4” to select the desired stitch pattern.
Press the  key to select satin stitch pattern 14.

Press the OK key to close the quick stitch selection window.



Quilt Block Advisor

Refer to pages 80-81.

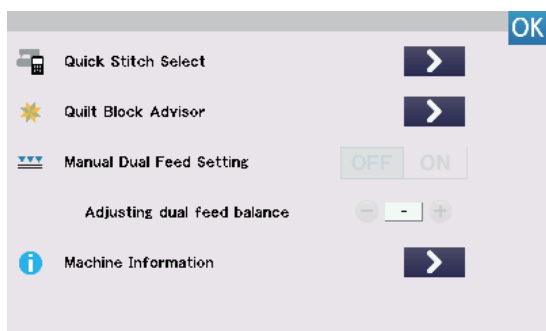
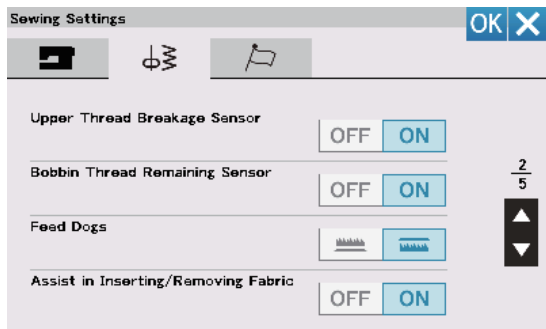
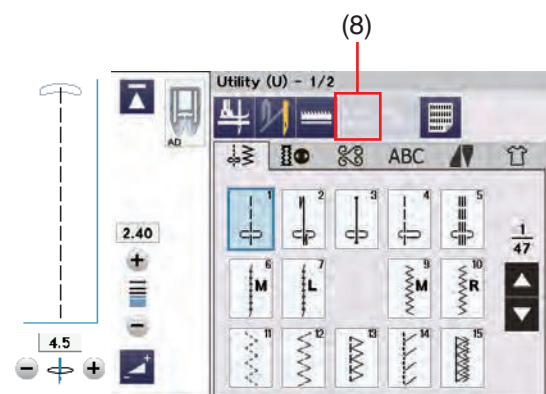
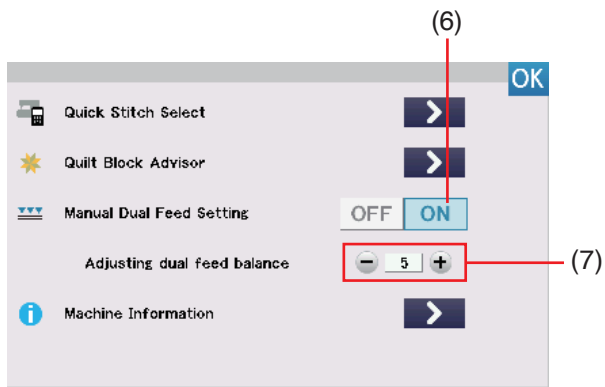

Manual Dual Feed Setting

If you wish to sew patterns other than U1 to U5 and Q1 to Q7 with the dual feed drive, turn on the manual dual feed setting.

Press the ON key of the manual dual feed setting.

(6) ON key

NOTE:

The sewing results of the manual dual feed sewing may vary depending upon sewing conditions. Always make a test stitch on an extra piece of the fabric to check the sewing results.

You may need to adjust the dual feed balance depending on the type of fabric. Refer to page 42 for how to adjust the dual feed balance.

(7) Adjusting dual feed balance

Turn off the manual dual feed setting when the manual dual feed sewing is finished.

NOTE:

- The dual feed key will gray out if the manual dual feed setting is turned on.
- The patterns U8 and B14, and the sewing applications that are not suitable for the manual dual feed setting are grayed out and cannot be selected.

(8) Dual feed key

NOTE:

If the drop feed key in the sewing setting mode is turned on, the manual dual feed setting will gray out. If the pattern or sewing application with the feed dogs down is selected, the manual dual feed setting will gray out.

Dual feed sewing was canceled.

OK

Cancel manual dual feed setting
and lower feed dogs?

OK X

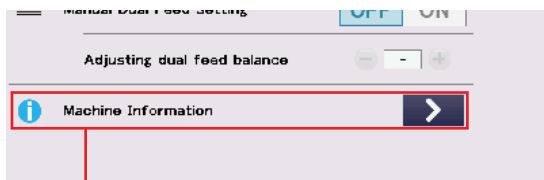
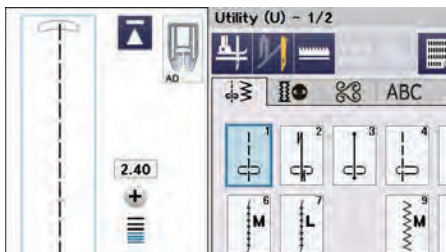
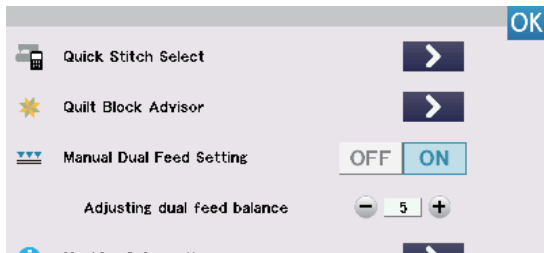
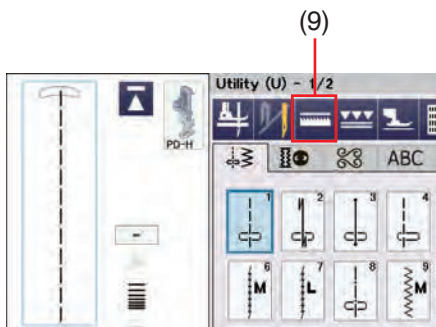

(5)

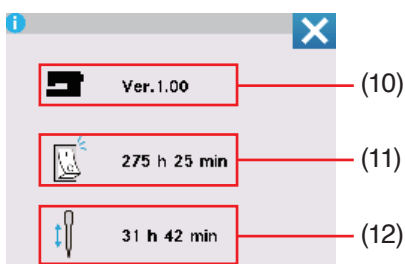

NOTE:

If the manual dual feed setting is turned on when dual feed sewing is turned on in ordinary sewing mode, dual feed sewing will be switched to the manual dual feed setting.

NOTE:

If the drop feed key is turned on in ordinary sewing mode when the manual dual feed setting is turned on, a message will appear as shown. Press the OK key to turn off the manual dual feed setting, and the feed dogs are dropped. To cancel dropping the feed dogs, press the X key.
(9) Drop feed key

NOTE:

If the manual dual feed setting is turned on when the drop feed key is turned on in ordinary sewing mode, the feed dogs are raised for dual feed sewing.
(9) Drop feed key

Machine Information

You can see software version of the machine, total power-on time of the machine and total operating time of the machine.

Press the  key of the Machine Information (5) to open the machine information window.

- (10) Software version
- (11) Total power-on time
- (12) Total operating time

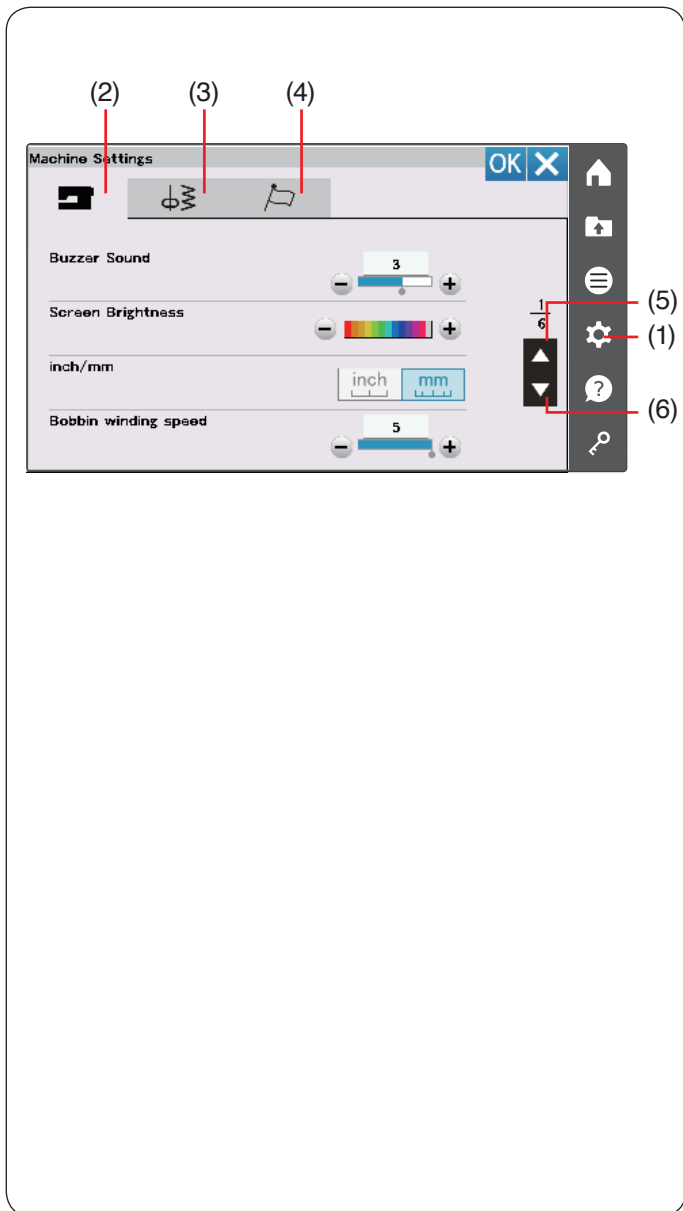

Customizing Machine Settings

Press the set mode key to enter the machine setting mode.

You can select various options and customize the machine settings to suit your personal preference.

- (1) Set mode key

Press one of the 3 keys to select the mode to customize.

(2) Machine setting mode key

Press the machine setting mode key to enter the common setting mode.

In this mode, you can customize the general machine settings and options (refer to pages 137-139).

(3) Sewing setting mode key

Press the sewing setting mode key to enter the ordinary sewing setting mode.

In this mode, you can customize the machine settings and options for ordinary sewing (refer to pages 139-141).

(4) Language setting mode key

Press the language setting mode key to enter the language setting mode. In this mode, you can select the desired language for the screen messages (refer to page 141).

To browse pages in each mode, press the next page key or previous page key.

- (5) Previous page key
- (6) Next page key

Registering the custom settings

After customizing the settings, press the OK key to enable the new settings.

To cancel the changes to the settings, press the X key and the setting mode window will close.

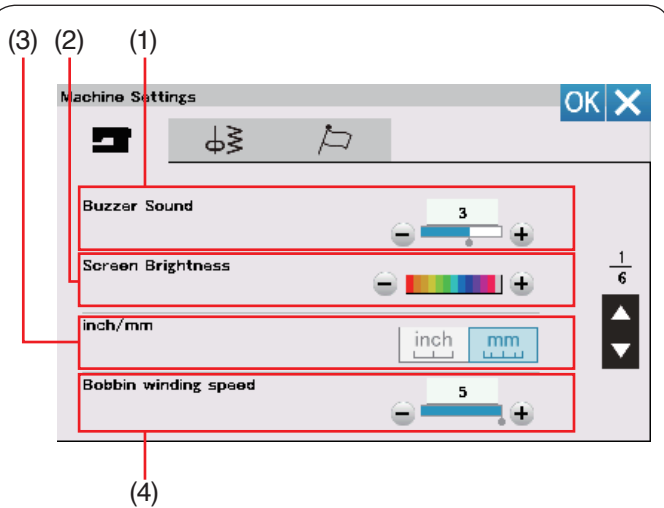

Machine Setting Mode

(1) Buzzer Sound

The signal sound can be adjusted by pressing the “+” or “-” key. Set the value to “OFF” by pressing the “-” key several times to mute the signal sounds.

(2) Screen Brightness

You can adjust the brightness of the visual touch screen by pressing the “+” or “-” key.

(3) inch/mm

You can set your machine’s dimensional unit to either inches or millimeters by pressing the “inch” or “mm” key. The default unit is millimeters.

(4) Bobbin winding speed

If you wish to wind the bobbin thread more quickly or slowly, you can adjust the maximum bobbin winding speed by pressing the corresponding key.

Press the next page key to show the next menu.

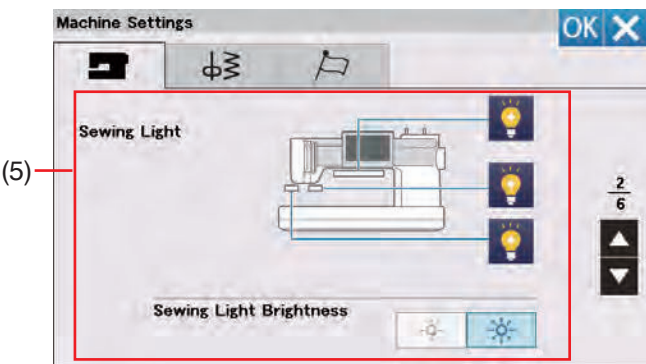

(5) Sewing Light

The sewing lights can be turned on or off individually. Press the corresponding light keys to turn on or off the sewing lights. You can choose the brightness of sewing light to either bright light or low light.

Press the next page key to show the next menu.

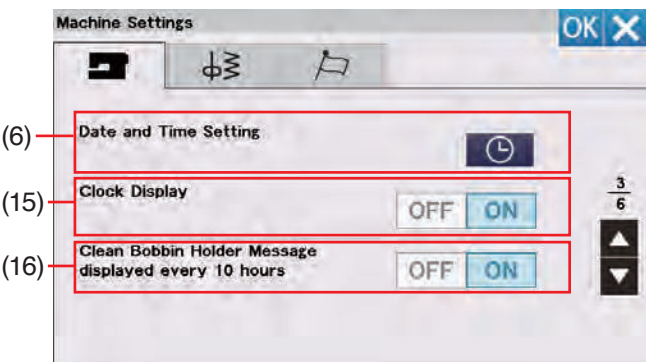

(6) Date and Time Setting

Press the clock key to set date and time. Set the Year, Month, Day, Hour and Minute by pressing the “+” or “-” key. You can select the display for the time 24-hour clock or 12-hour clock. If you select the display for the time 12-hour clock, you can also select the display for the time AM or PM.

- (7) Year
- (8) Month
- (9) Day
- (10) Hour
- (11) Minute
- (12) 24-hour clock
- (13) 12-hour clock
- (14) AM / PM

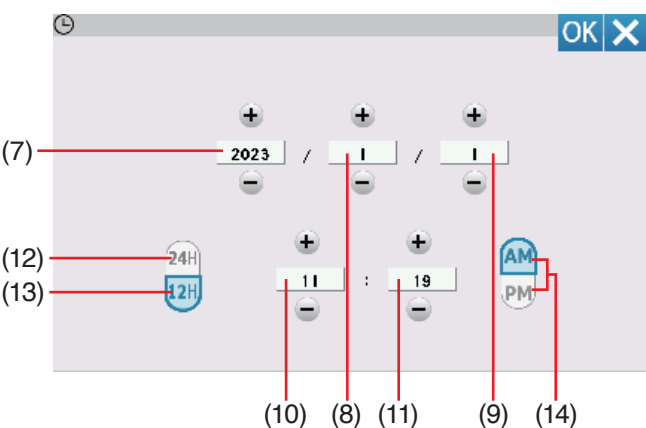

(15) Clock Display

The clock display can be turned on or off.

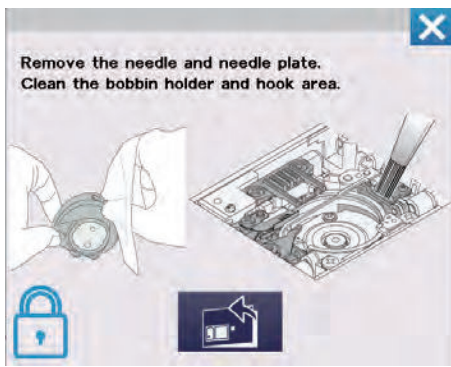

(16) Clean Bobbin Holder Message displayed every 10 hours

The caution message for cleaning the bobbin holder and the hook race will be displayed when the certain time (10 hours) passes if this option is turned on. The caution message will not be displayed when this option is turned off.

Press the next page key to show the next menu.

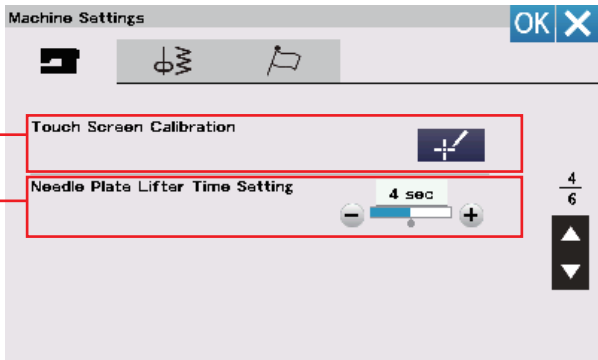

(17) Touch Screen Calibration

You can calibrate the key positions of the touch screen if you feel the touch screen key is not responding properly. Press the calibration key to open the calibration window.

Press the “+” sign with the touch panel stylus as the sign appears.

When you press the last sign, the screen shows “END” and the calibration window will close.

(18) Needle Plate Lifter Time Setting

You can set the needle plate lifting time between 2-6 seconds.

Press the next page key to show the next menu.

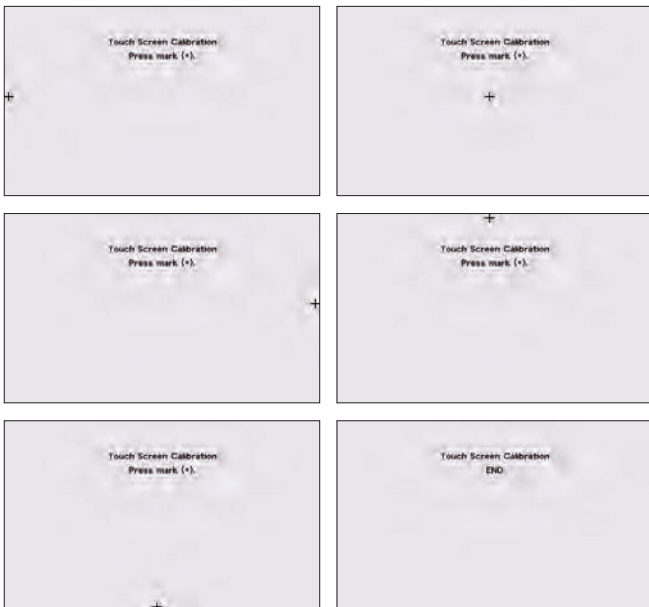

(19) Standby Timer

The sewing lights will turn off and the machine will enter standby mode if you do not use the machine within the time period set by this timer. Doing any operation will turn the lights and screen on again.

The standby timer can be set from 1 to 30 minutes. If you wish to turn off the timer, press and hold the “+” key until “OFF” shows in the timer window.

(20) Screen Saver

Press the ON/OFF key to turn on the screen saver, and the visual touch screen will show the screen saver when the machine is in standby status.

Press the import key to import a screen saver from a USB flash drive.

You can create an original screen saver with ScreenSaverTool.

The imported screen saver data will be deleted if the delete key is pressed, or the internal memory is formatted (refer to page 139).

(21) Import key

(22) Auto-off (Time Setting)

The machine will be automatically turned off if you do not use the machine within the time period set by this timer.

The auto-off timer can be set from 1 to 12 hours.

If you wish to turn off the timer, press and hold the “+” key until “OFF” shows in the timer window.

To turn on the machine again, turn the power switch on.

NOTE:

The auto-off timer is available in EU countries and some regions which use 200 - 240 voltage standards.

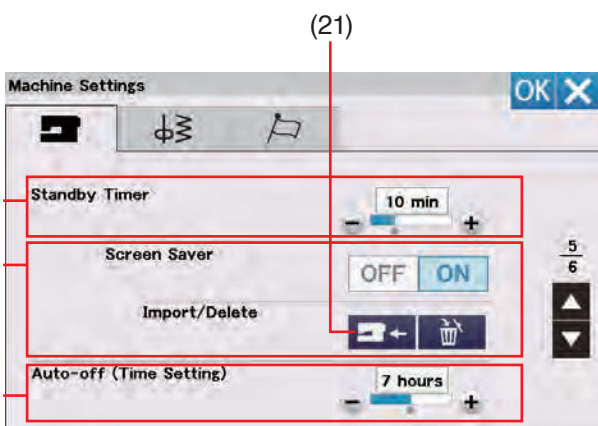

Press the next page key to show the next menu.

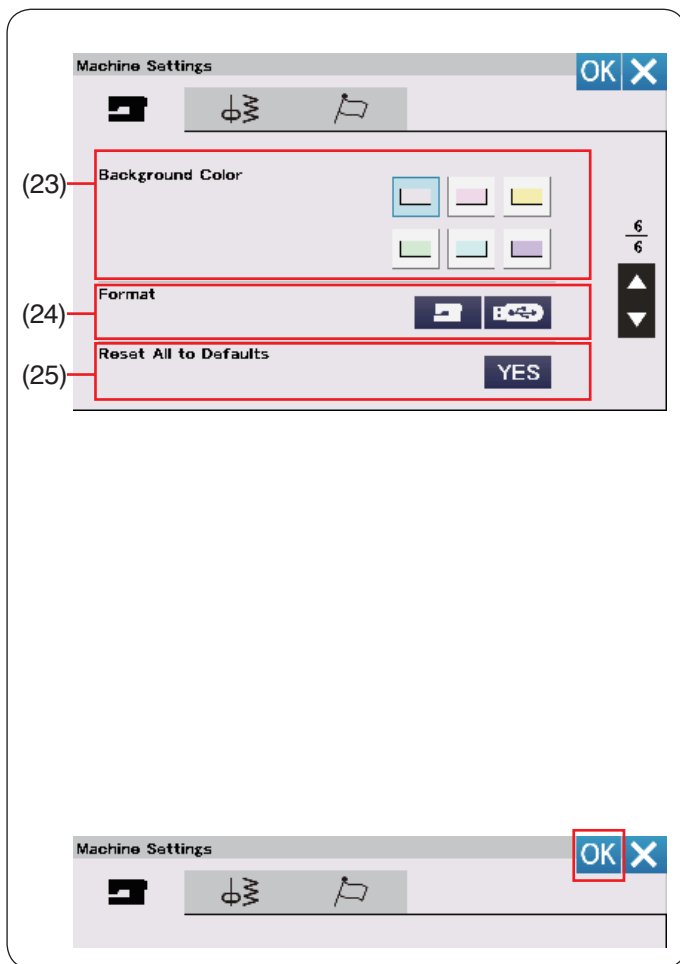

(23) Background Color

You can select from the colorful wallpapers for the background of the visual touch screen by pressing the relevant key.

(24) Format

If the internal memory of the machine or USB flash drive does not function due to damage to the memory bank, you need to re-enable it by formatting the memory.

To format the machine's internal memory, press the machine key and a confirmation message will appear. Press the OK key to format.

To format a USB flash drive, press the USB key and the confirmation window will open. Press the OK key to format.

⚠ CAUTION:

Do not turn off the power or disconnect the USB flash drive while a warning message is displayed otherwise it may damage the memory bank.

NOTE:

- This model supports FAT16 and FAT32 formats only. If the USB flash drive is not read, check its format (refer to pages 149-150).
- Do not use a USB card reader and USB hub.

(25) Reset All to Defaults

Press the YES key to reset all the parameters to the original values (factory settings).

After customizing the settings, press the OK key to enable the new settings.

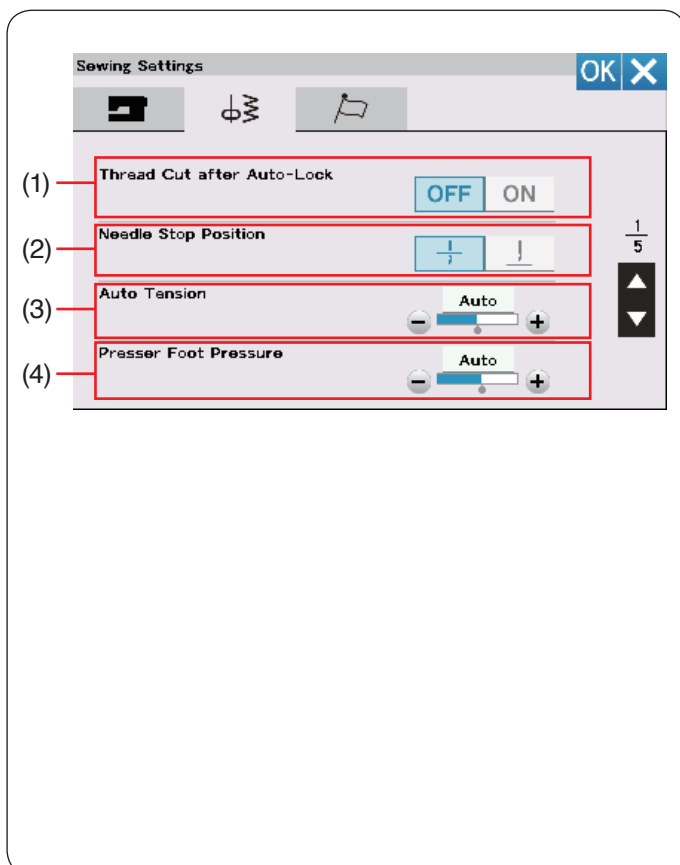

Sewing Setting Mode

(1) Thread Cut after Auto-Lock

The machine automatically trims the threads after sewing locking stitches when this option is turned on.

(2) Needle Stop Position

The machine always stops with the needle in the down position except when sewing buttonholes, specialty stitches, monograms, etc. However you can change the needle stop position to up by pressing the needle up key.

NOTE:

The machine stops with the needle in the down position if Foot-up key option is turned on, even if the needle stop position is set to up position.

(3) Auto Tension

You can adjust the auto thread tension level by pressing the "+" or "-" key.

(4) Presser Foot Pressure

The foot pressure is automatically optimized but you can adjust the foot pressure manually by pressing the "+" key or "-" key.

Press the next page key to show the next menu.

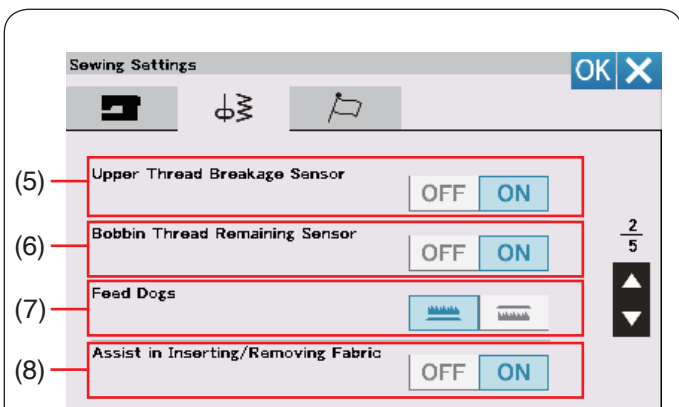

(5) Upper Thread Breakage Sensor

If you want to turn off the auto-stop function when the upper thread (needle thread) breaks, turn off the upper thread breakage sensor.

(6) Bobbin Thread Remaining Sensor

If you want to turn off the auto-stop function when the bobbin thread runs out, turn off the bobbin thread remaining sensor.

(7) Feed Dogs

Press the right side of this option if you wish to sew decorative stitches and sewing applications with the feed dogs down.

Press the drop feed key to change this option to drop.

(8) Assist in Inserting/Removing Fabric

Set the feed dogs up or down automatically when the presser foot is raised.

Press the next page key to show the next menu.

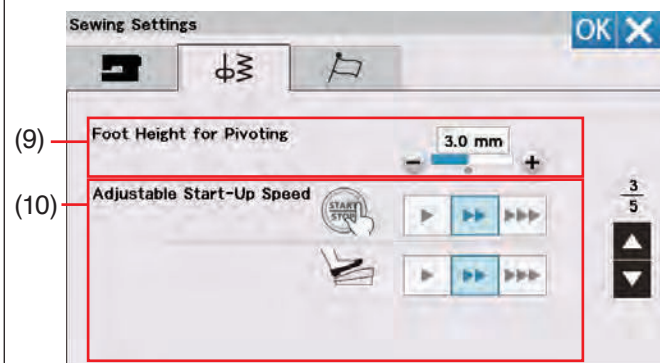

(9) Foot Height for Pivoting

When the foot up option is turned on, the presser foot will automatically go up when the machine stops.

The height of the foot in the up position can be adjusted by pressing the “+” key or “-” key in accordance with thickness of the fabrics.

(10) Adjustable Start-Up Speed

The machine will start running slowly and the sewing speed will gradually increase to maximum. You can select the desired start-up speed from slow, medium or high by pressing the corresponding key, and set the speed for the start/stop button or foot control individually. Press the next page key to show the next menu.

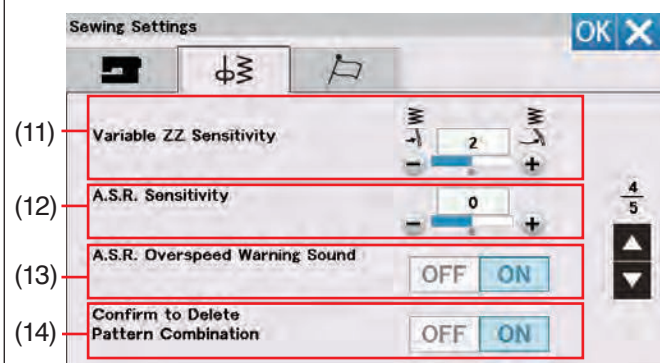

(11) Variable ZZ Sensitivity

You can adjust the amount of needle swing with the knee lifter movement for variable zigzag in sewing applications.

Press the “+” key so the needle swings a small amount when moving the knee lifter.

Press the “-” key so the needle swings a large amount when moving the knee lifter.

(12) A.S.R. Sensitivity

You can adjust and save the A.S.R. sensitivity setting. Press the “+” key to increase A.S.R. sensor sensitivity. Example: Press the “+” key when the stitch length is not stable or the sewing speed changes too slowly. Press the “-” key to decrease A.S.R. sensor sensitivity. Example: Press “-” key when the sewing speed is too fast.

(13) A.S.R. Overspeed Warning Sound

The buzzer sounds when the fabric moves faster than the value set by A.S.R. Sensitivity. Press the “OFF” key to delete the buzzer sound.

(14) Confirm to Delete Pattern Combination

When the combination mode is cancelled, a message will appear before deleting patterns. When “OFF” is selected, the confirmation message will not be displayed.

Press the next page key to show the next menu.

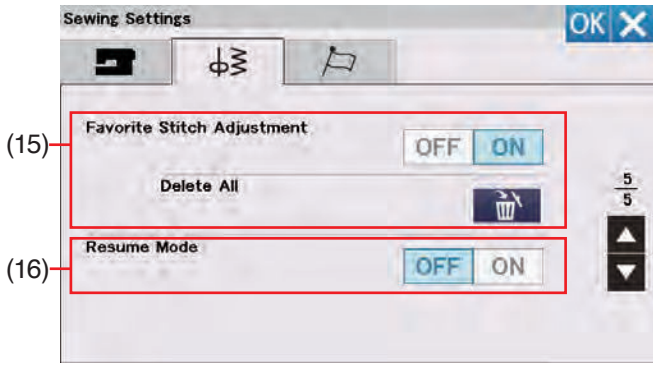

OK **X**

Resume last pattern?
If you cancel the pattern resuming,
the previous pattern will be deleted.

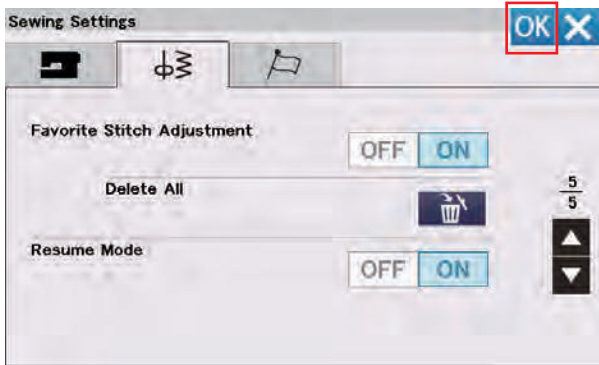

(15) Favorite Stitch Adjustment

If you wish to save the changes to manual stitch settings, turn on this option by pressing the ON key. Press the  key to clear the manual stitch setting.

NOTE:
 This option is available for all stitches except monogram and created stitches.

(16) Resume Mode

Turn on this option when you wish to resume the last pattern sewn before turning the power switch off.

When the power is turned on again, the confirmation message will appear. Press the OK key to resume the last pattern.

NOTE:
 Resume data will be cleared under the following conditions:

- Created stitch is imported with the import key.
- Created stitch is deleted with the delete key.
- The internal memory is formatted.

After customizing the settings, press the OK key to enable the new settings.

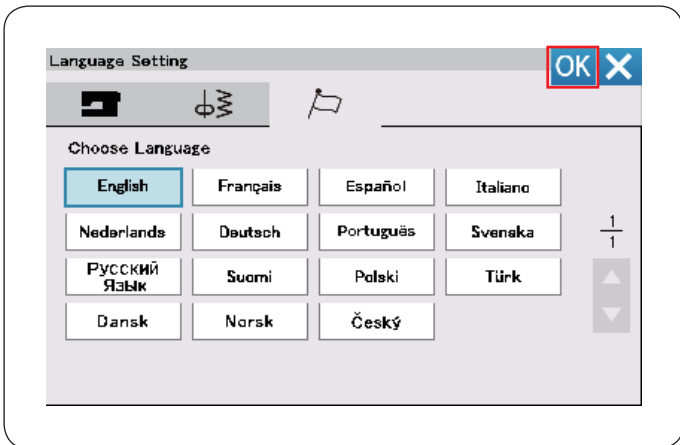

Language Setting Mode

Select the desired language and press the OK key. The visual touch screen shows messages in the selected language.

CARE AND MAINTENANCE

WARNING:

Turn the power switch off and unplug the machine before cleaning.
Do not dismantle the machine in any way other than as explained in this section.

CAUTION:

Do not store the machine in a high-humidity area, near a heat radiator, or in direct sunlight. Store the machine in cool dry place.
Clean the outside of the machine with a soft cloth.
Do not use chemical solvents.

Cleaning the Hook Area

Clean the hook area at least once a month.

1. Remove the needle and foot holder (refer to pages 22 and 24).

Remove the needle plate (refer to page 34).

Turn the power switch off and unplug the machine.
Take out the bobbin and bobbin holder.

(1) Bobbin holder

2. Clean the bobbin holder with a lint brush.

Wipe the bobbin holder both inside and outside with a soft cloth.

(2) Lint brush

(3) Soft cloth

3. Clean the feed dogs, auto thread cutter device and around the bobbin thread remaining sensor with the lint brush.

(4) Feed dogs

(5) Auto thread cutter device

(6) Bobbin thread remaining sensor

4. Clean the hook race with a soft cloth.

(7) Soft cloth

5. Insert the bobbin holder so that the knob fits next to the stopper in the hook race.

Insert the bobbin.

Attach the needle plate, foot holder and needle.

(8) Knob

(9) Stopper

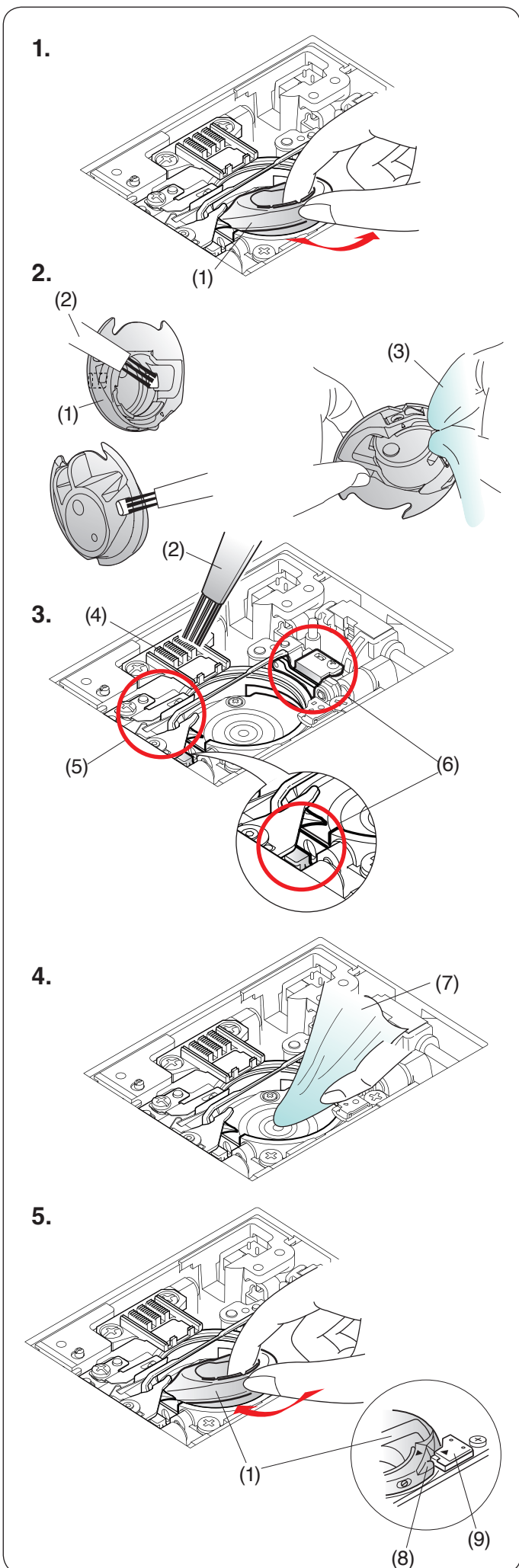

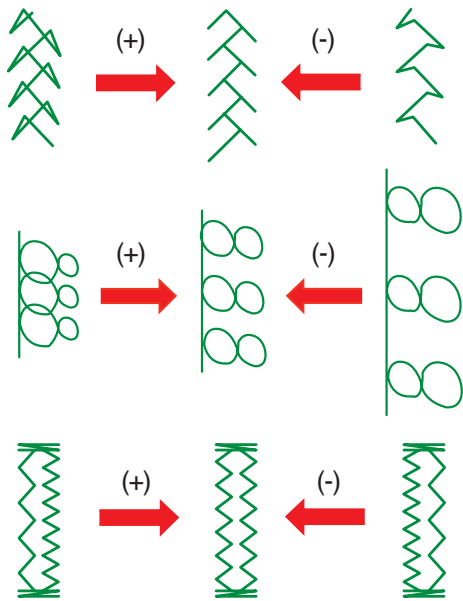
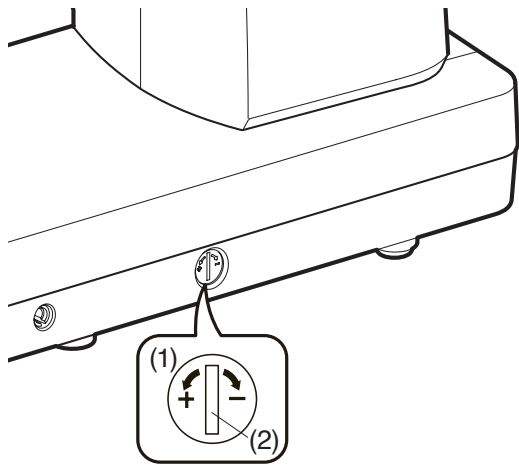

Correcting Distorted Stitch Patterns

Sewing results of the stitch patterns may vary depending upon sewing conditions, such as sewing speed, type of the fabric, number of layers etc.

Always test sew on an extra piece of the fabric that you wish to use.

If decorative stitch patterns, monogram or the stretch buttonhole are distorted, correct them with the feed balancing dial.

- (1) Feed balancing dial
- (2) Neutral position

NOTE:

Return the feed balancing dial to its neutral position when sewing is finished.

Stretch stitch pattern (Q25)

If the pattern is compressed, turn the feed balancing dial in the direction of “+”.

If the pattern is drawn out, turn the feed balancing dial in the direction of “-”.

Letters and numbers

If the pattern is compressed, turn the feed balancing dial in the direction of “+”.

If the pattern is drawn out, turn the feed balancing dial in the direction of “-”.

Stitch balance of the stretch buttonholes (B10)

If the right row is denser, turn the dial in the direction of “+”.

If the left row is denser, turn the dial in the direction of “-”.

Replacing the Coin Cell Battery for the Internal Clock

If the clock on the visual touch screen always indicates "0:00" when turning the power switch on, replace the coin cell battery in the sewing machine.

WARNING:

- Battery may explode if mistreated. Do not recharge, disassemble or dispose of in fire.
- Turn off the power switch before replacing the battery.
- Replace the battery with "CR2032" only. Use of another may present a risk of fire or explosion.
- Chemical Burn Hazard. Keep the battery away from children.
- The batteries must be disposed of properly.

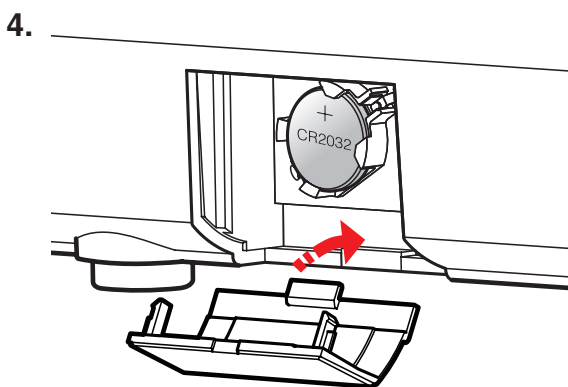
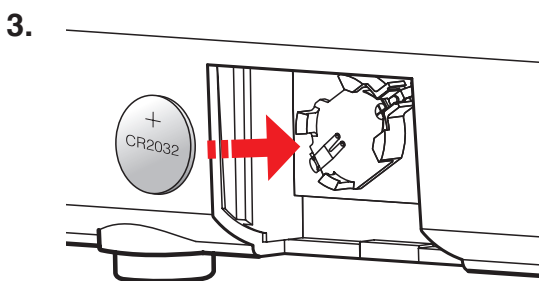
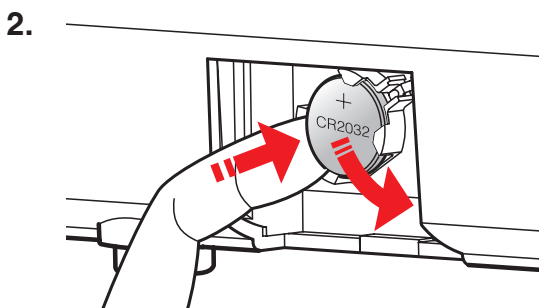
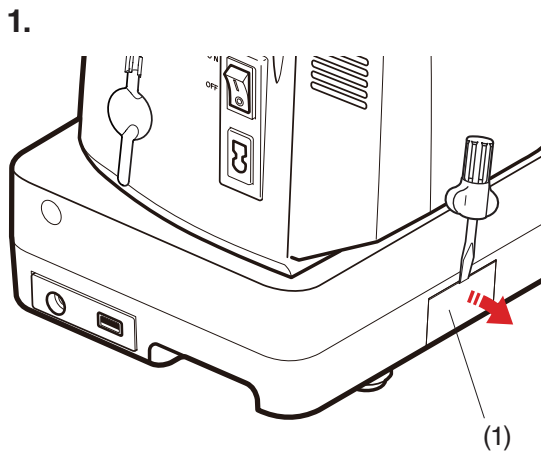

1. Remove the battery cover with a screwdriver.

(1) Battery cover

2. Remove the coin cell battery.

3. Install the battery "CR2032" with the "+" mark facing up.

4. Attach the battery cover.

Set the clock again after replacing the battery (refer to page 137).

Replacing the Needle Plate for Emergency

CAUTION:

Never turn the needle plate release dial while running the machine.

If the needle plate will not automatically snap off when pressing the needle plate release key on the lockout screen, you can replace the needle plate using the needle plate release dial.

(1) Needle plate release key

1. Raise the needle by turning the handwheel.

Raise the presser foot.

Remove the needle plate release dial cap with a screwdriver.

(2) Needle plate release dial cap

2. Push and turn the needle plate release dial clockwise with the screwdriver to remove the needle plate.

(3) Needle plate release dial

3. A warning message will appear that the needle plate is not secured.

Turn the needle plate release dial counterclockwise with the screwdriver to be at set position.

Attach the needle plate.

(4) Set position

4. A message will appear, so that press the X key after attaching the proper presser.



(1)

1.

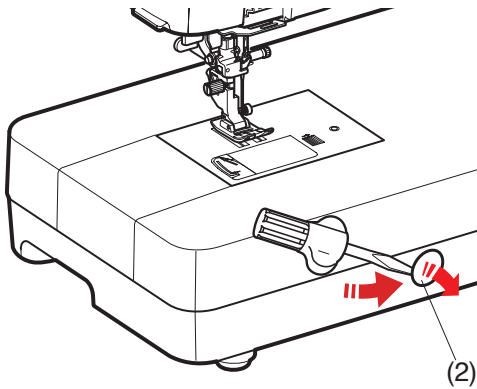

(2)

2.

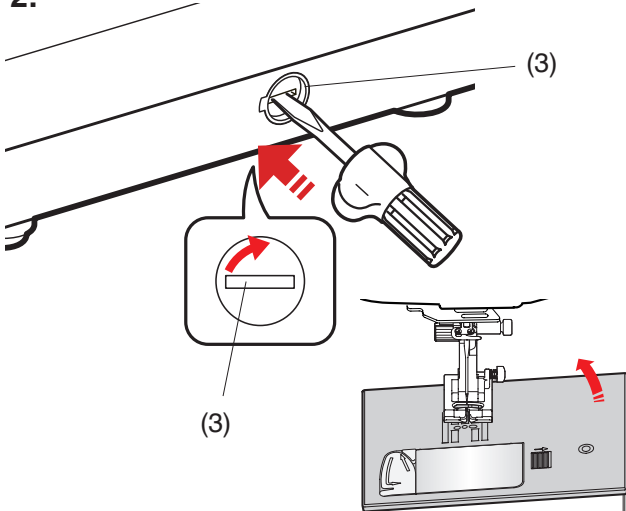

(3)

3.

 **Warning**
The needle plate is not secured.
Be sure that needle plate release dial is at set position.
Attach needle plate.

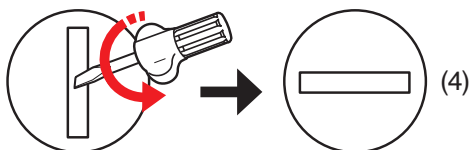
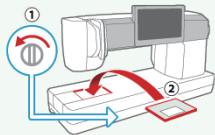

(4)





4.

 Please make sure the proper presser foot is attached.

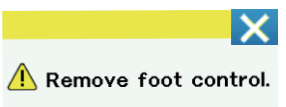

Problems and Warning Signals

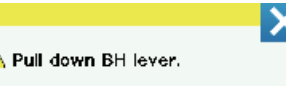
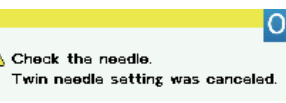
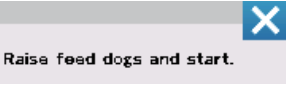
If a buzzer sounds and the visual touch screen shows a warning sign, follow the guidance below.

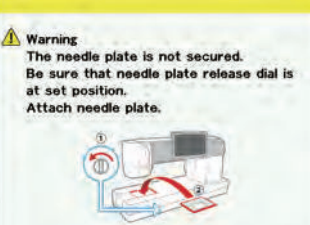
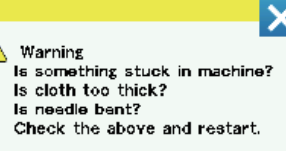
Warning Sign	Cause	Try this
 <p>Remove foot control.</p>	The start/stop button is pressed with the foot control connected.	Disconnect the foot control.
 <p>Warning</p>	The foot control is broken.	Contact the service center or the store from whom the machine was purchased.
 <p>Pull down BH lever.</p>	The machine will stop if the buttonhole is sewn without lowering the buttonhole lever.	Lower the buttonhole lever and start the machine again (refer to page 58).
 <p>Check the needle. Twin needle setting was canceled.</p>	The twin needle key is pressed when the twin needle sign is indicated on the visual touch screen.	Replace the twin needle with a single needle and press the OK key (refer to page 24).
 <p>Raise feed dogs and start.</p>	The machine is started with the feed dogs lowered.	Raise the feed dogs unless you want to sew with the feed dogs lowered (refer to page 37).
 <p>Warning The needle plate is not secured.</p>	<p>The needle plate is removed.</p> <p>The needle plate is not properly attached to the set position.</p>	Attach the needle plate. Check if the needle plate is attached properly (refer to page 34).
 <p>Warning The needle plate is not secured. Be sure that needle plate release dial is at set position. Attach needle plate.</p>	The needle plate is removed with the needle plate release dial.	Turn the needle plate release dial at set position. Attach the needle plate (refer to page 145).
 <p>Warning Is something stuck in machine? Is cloth too thick? Is needle bent? Check the above and restart.</p>	The machine stops due to overload.	Wait for at least 15 seconds to restart. Remove tangled threads around the take-up lever, hook race and auto thread cutter device.

Troubleshooting

Condition	Cause	Reference
The needle thread breaks	<ol style="list-style-type: none"> 1. The needle thread is not threaded properly. 2. The needle thread tension is too tight. 3. The needle is bent or blunt. 4. The needle is incorrectly inserted. 5. The needle thread is not set under the presser foot when start sewing. 6. The fabric is moved too fast when stitching free motion quilting. 7. The thread is tangled around the spool. 	Pages 30-31 Page 49 Change the needle. Page 24 Page 39 Page 124 Use the spool holder.
The bobbin thread breaks	<ol style="list-style-type: none"> 1. The bobbin thread is not threaded properly in the bobbin holder. 2. Lint has collected in the bobbin holder. 3. The bobbin is damaged and does not turn smoothly. 	Page 29 Page 142 Change the bobbin.
The needle breaks	<ol style="list-style-type: none"> 1. The needle is incorrectly inserted. 2. The needle is bent. 3. The needle clamp screw is loose. 4. The needle is too fine for the fabric being used. 5. An inappropriate presser foot is used. 6. The fabric was pulled toward you when sewing free motion quilting with the open-toe foot. 	Page 24 Change the needle. Page 24 Page 25 Use the correct foot. Page 124
Skipped stitches	<ol style="list-style-type: none"> 1. The needle is incorrectly inserted, bent or blunt. 2. The needle and/or threads are not suitable for the work being sewn. 3. A blue tip needle is not being used for sewing stretch, very fine fabrics and synthetic fabrics. 4. The needle thread is not threaded properly. 5. A poor quality needle is used. 6. A purple tip needle is not being used for sewing thick fabrics, denims and across the hem. 	Page 24 Page 25 Use the stretch stitch needle. Pages 30-31 Change the needle. Page 25
Seam puckering	<ol style="list-style-type: none"> 1. The needle thread tension is too tight. 2. The needle thread is not threaded properly. 3. The needle is too heavy for the fabric being sewn. 4. The stitch length is too long for the fabric. 5. The foot pressure is not adjusted properly. 6. A stabilizer is not used when sewing very fine fabrics. 	Page 49 Pages 30-31 Page 25 Make stitch shorter. Page 50 Apply a stabilizer.
The fabric is not feeding smoothly	<ol style="list-style-type: none"> 1. The feed dogs are packed with lint. 2. The stitches are too fine. 3. The feed dogs are not raised after “drop feed” sewing. 	Page 142 Make stitch longer. Page 37
Loops on the seams	<ol style="list-style-type: none"> 1. The needle thread tension is too loose. 2. The needle is too thick or too fine for the fabric. 	Page 49 Page 25
The machine does not run	<ol style="list-style-type: none"> 1. The machine is not plugged in. 2. Thread is caught in the hook race. 3. The start/stop button is used with the foot control plugged in. 	Pages 11-12 Page 142 Page 12
Buttonhole sewing is not sewn properly	<ol style="list-style-type: none"> 1. The stitch density is not suitable for the fabric being sewn. 2. The interfacing has not been used for the stretch or synthetic fabric. 3. The buttonhole lever is not lowered. 	Page 60 Apply an interfacing. Page 58
The machine is noisy	<ol style="list-style-type: none"> 1. Thread is caught in the hook race. 2. Lint is built up in the hook race or bobbin holder. 	Page 142 Page 142
Auto thread cutting failed	<ol style="list-style-type: none"> 1. Thread is too thick for the auto thread cutting. 2. Threads are caught in the auto thread cutter device. 	Page 16 Page 142
Pattern selection keys are grayed out	<ol style="list-style-type: none"> 1. The needle plate for straight stitch is attached to the machine. 2. Dual feed key is on. 3. Floating mode key is on. 4. Twin needle key is on. 5. A.S.R. key is on. 	Page 34 Pages 42-43 Page 45 Page 85 Page 125
Keys on the visual touch screen and touch panel keys do not work	<ol style="list-style-type: none"> 1. The key position is out of alignment. 	Page 138

Condition	Cause	Reference
The sewing speed does not increase and buzzer sounds when using the A.S.R. foot holder.	1. The speed control slider is at the left side (low position).	Move the speed control slider to the rightmost (maximum sewing speed).
Visual touch screen is not clear	1. The screen brightness is not adjusted properly.	Page 137
The needle thread appears on the wrong side of the fabric when the stitch width value is larger than “7.0”	1. Thread tension is not balanced.	Page 49
The bobbin thread remaining sensor does not work; There is no signal sound when the bobbin thread is run out and the machine does not stop sewing	1. The bobbin thread remaining sensor is turned off. 2. Lint has collected around the bobbin thread remaining sensor. 3. A bobbin other than the “J” plastic bobbin is used.	Page 140 Page 142 Page 26
The message “Bobbin thread is not sufficient.” appears and the machine stops, although there is enough amount of thread wound on the bobbin.	1. A strong light such as a white light bulb or LED light illuminates the area around the hook cover on the needle plate.	Do not shine the area around the hook cover on the needle plate with strong light.
The USB flash drive is not read	1. Format setting of the USB flash drive is not correct. 2. The USB flash drive is malfunctioning.	Pages 149-150 Replace the USB flash drive.

It is not abnormal for a faint humming sound to be heard from the internal motors.
The visual touch screen may become warm after several hours of continuous use.

Formatting USB Flash Drives

NOTE:

Formatting of USB flash drive must be carried out on a personal computer using Microsoft Windows.*

For Windows 11 and 10 users, screen shot samples using Windows 11 are shown.

1. Using File Explorer, right click on the USB flash drive. Click format.

(1) Format

1.

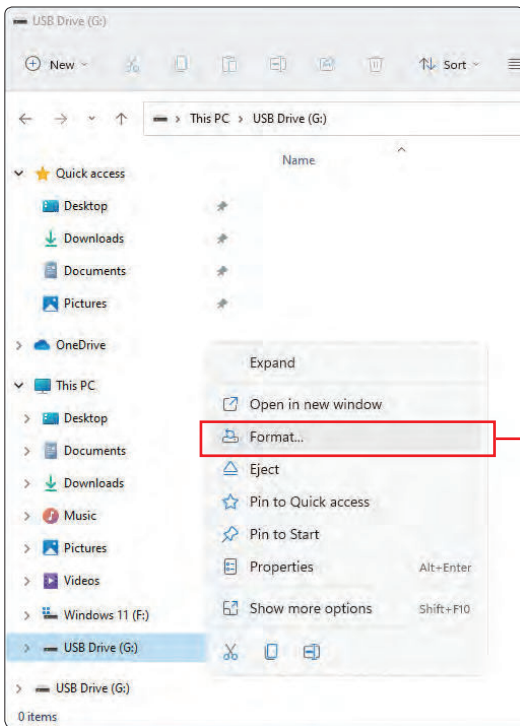

2. 3. 4.

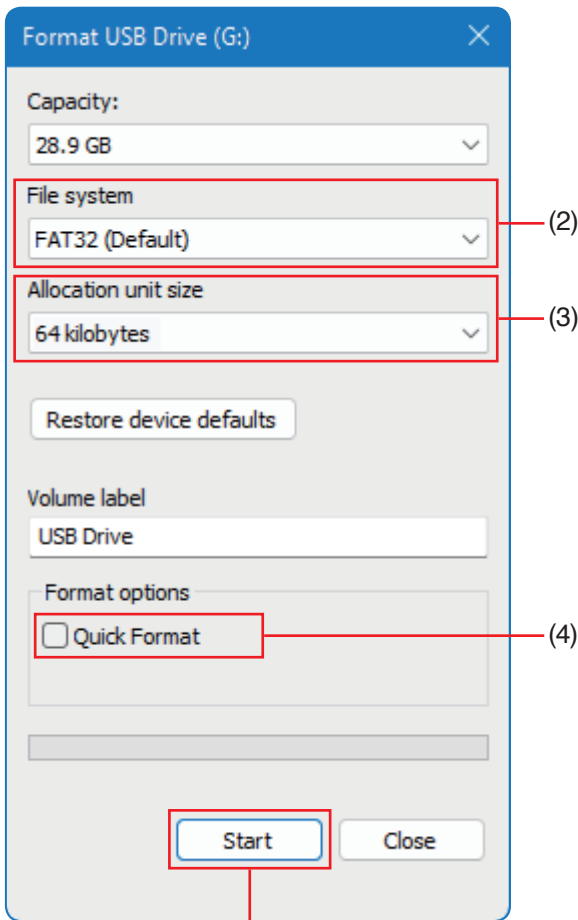

2. Format window will be displayed. Select FAT16 or FAT32 from file system.

(2) File system

NOTE:

If FAT16 or FAT32 cannot be selected, use other PC. Or use other USB flash drive which can be read.

3. From allocation unit size, select a size of 64 kilobytes or less.

(3) Allocation unit size

NOTE:

Do not check the quick Format.

(4) Quick Format

4. Click the start key.

(5) Start key

* Windows is a registered trademark of Microsoft Corporation.

5.

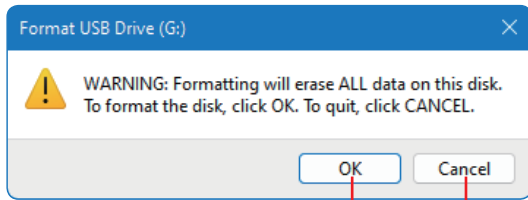

(7)

(6)

6.

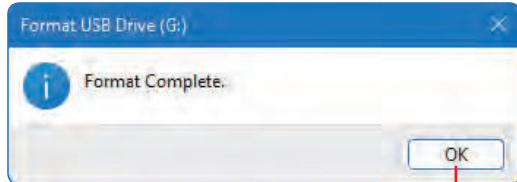

(8)

5. After the start key is clicked, the confirmation message will be displayed.

NOTE:

If there is any important data remaining on the USB flash drive, click the cancel key.

After saving the data elsewhere, begin the process again from 1.

(6) Cancel key

Click the OK key to begin formatting.

(7) OK key

6. A message will be displayed when the formatting is complete.

Click the OK key.

(8) OK key

Stitch Chart

Utility (U)



Buttonhole (B)

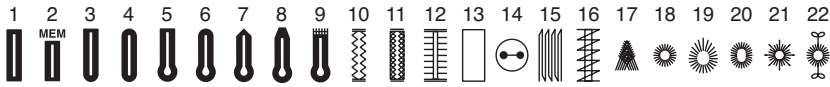

Applique (A)

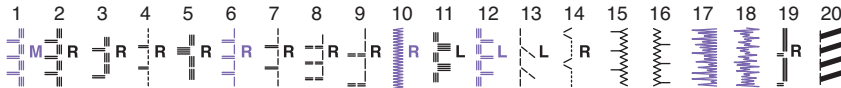

Cross-Stitch (C)



Heirloom (H)

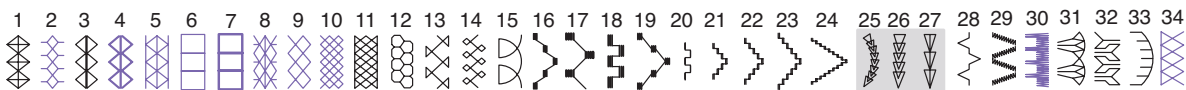

Quilt (Q)

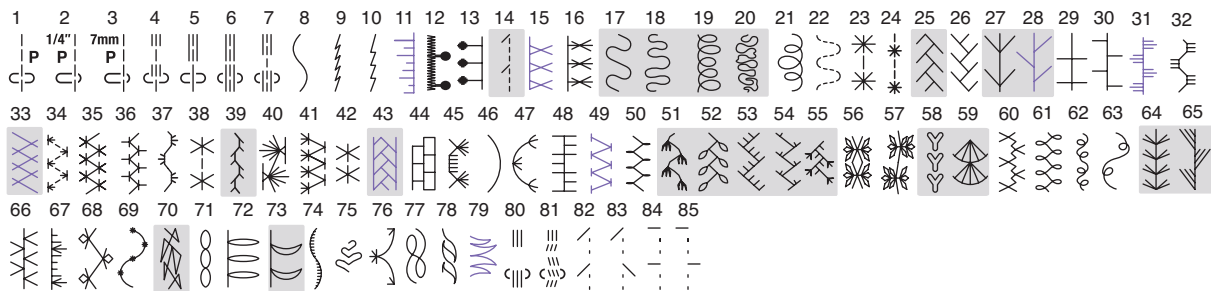

Quilt Style (QS)

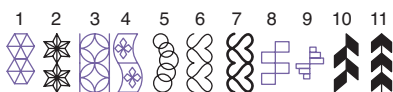

Satin (S)



Bridge (BR)

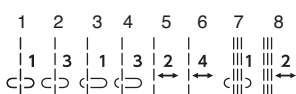

* Stitch patterns in purple can be tapered.

* Stitch patterns shaded in light gray can be flipped vertically (Horizontal mirror image).

Stitch Chart

Decorative (D)

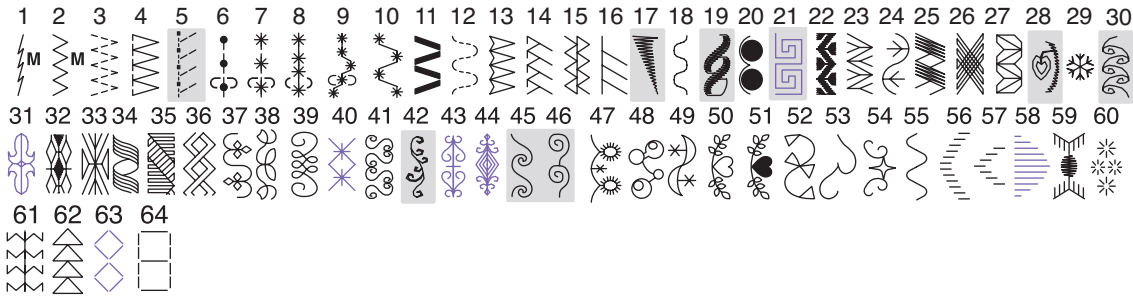

Botanical (BO)



Long (L)

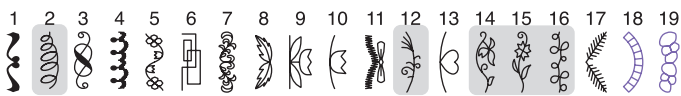

Animals (AN)

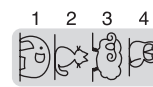

Life Style (LS)

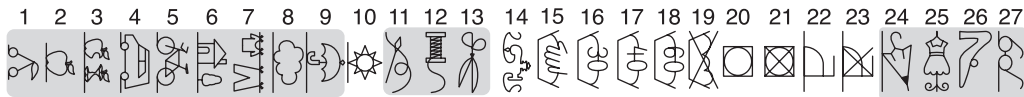

Kids (K)

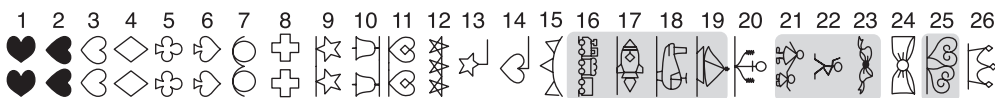

Seasons (SE)



Words (W)

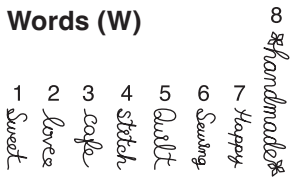

Mirage (M)



* Stitch patterns in purple can be tapered.

* Stitch patterns shaded in light gray can be flipped vertically (Horizontal mirror image).

Stitch Chart (Monogram)

Block

A B C D E F G H I J K L M N
 O P Q R S T U V W X Y Z . □ □ □
 a b c d e f g h i j k l m n
 o p q r s t u v w x y z . □ □ □
 1 2 3 4 5 6 7 8 9 0 & _ \$ @ . • ,
 ? ¿ ! ; ‘ ’ < > () - + = / // % ~ :
 À Á Â Ã Ä Å Æ Ç È É Ê Ë Ì Í Î Ï Ñ
 Ò Ó Ô Õ Ö Ø Ù Ú Û Ü ß à á â ã ä å æ ç è é ê ë ì í î ï ñ
 Ł ł Ń ń Œ œ Š š Ÿ Ž ž Ž
 à á â ã ä å æ ç è é ê ë ì í î ï ñ
 ò ó ô õ ö ø ù ú û ü ß à á â ã ä å æ ç è é ê ë ì í î ï ñ
 ł ł ń ń œ œ š š Ÿ ž ž ž

Script

A B C D E F G H I J K L M N
 O P Q R S T U V W X Y Z . □ □ □
 a b c d e f g h i j k l m n
 o p q r s t u v w x y z . □ □ □
 1 2 3 4 5 6 7 8 9 0 & _ \$ @ . •
 , ? ¿ ! ; ‘ ’ < > () - + = / // % ~ :
 A B C D E F G H I J K L M N
 O P Q R S T U V W X Y Z . □ □ □
 a b c d e f g h i j k l m n
 o p q r s t u v w x y z . □ □ □
 1 2 3 4 5 6 7 8 9 0 & _ \$ @ . •
 , ? ¿ ! ; ‘ ’ < > () - + = / // % ~ :
 À Á Â Ã Ä Å Æ Ç È É Ê Ë Ì Í Î Ï Ñ
 Ò Ó Ô Õ Ö Ø Ù Ú Û Ü ß à á â ã ä å æ ç è é ê ë ì í î ï ñ
 Ł ł Ń ń Œ œ Š š Ÿ Ž ž Ž
 à á â ã ä å æ ç è é ê ë ì í î ï ñ
 ò ó ô õ ö ø ù ú û ü ß à á â ã ä å æ ç è é ê ë ì í î ï ñ
 ł ł ń ń œ œ š š Ÿ ž ž ž

Stitch Chart (Monogram)

Broadway

A B C D E F G H I J K L M N
O P Q R S T U V W X Y Z . □ □ □
a b c d e f g h i j k l m n
o p q r s t u v w x y z . □ □ □
1 2 3 4 5 6 7 8 9 0 & _ \$ @ . •
, ? ¡ ! ¡ ‘ ’ < > () - + = / // % ~ :
À Á Â Ã Ä Å Æ Ç È É Ê Ë Ì Í Î Ï Ñ
Ò Ó Ô Õ Ö Ø Ù Ú Û Ü Þ À Á Ć Ć Ę Ğ Ĩ Ĭ
Ł Ń Ņ Œ Ś Ŝ Š Ÿ Ž ž Ž
à á â ã ä å æ ç è é ê ë ì í î ï ñ
ò ó ô õ ö ø ù ú û ü þ à á ć ĉ ċ ħ ħ ĩ ĵ
ł ń ń œ ś ŝ š Ÿ ž ž ž

Block (9mm)

A B C D E F G H I J K L M N
O P Q R S T U V W X Y Z . □ □ □
1 2 3 4 5 6 7 8 9 0 & _ \$ @ . •
, ? ¿ ! ¡ ‘ ’ < > () - + = / // % ~ :

Cyrillic

А Б В Г Г Д Ѓ Ђ Е Е Ё Ж З S
И І Ї Й Й Ј К Л Љ М Н Њ . □ □ □
О Ә П Р С Т Ћ У Ў Ф Х Ц Ч Ц
Ш Щ Ъ Ы Ь Э Ю Я . □ □ □
а б в г г д ѓ ђ е е ё ж з s
и і ї й й ј к л љ м н њ . □ □ □
о ә п р с т ћ у ў ф х ц ч ц
ш щ ѡ ѣ ѥ ю я . □ □ □
1 2 3 4 5 6 7 8 9 0 & _ \$ @ . •
, ? ¿ ! ¡ ‘ ’ < > () - + = / // % ~ :

Stitch Chart (Monogram)

Symbol

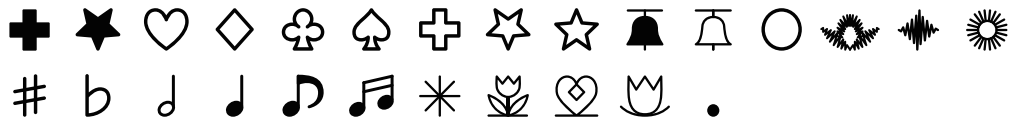

EC DECLARATION OF CONFORMITY

This machine complies with the following regulations:

EN 60335-1:2012;A11;A13;A1;A14;A2;A15

EN 60335-2-28:2003;A1;A11

EN 62233:2008

EN IEC 55014-1:2021

EN IEC 55014-2:2021

EN IEC 61000-3-2:2019;A 1

EN 61000-3-3:2013;A1;A2

EN 300 328 V2.2.2

ETSI EN 301 489-1 V2.2.3

ETSI EN 301 489-17 V3.2.4

Supplier: Elna International Corp. SA
Address: Rue de Veyrot 14 - 1217 Meyrin - Switzerland

